

Axial piston fixed motor A2FM/A2FE series 70

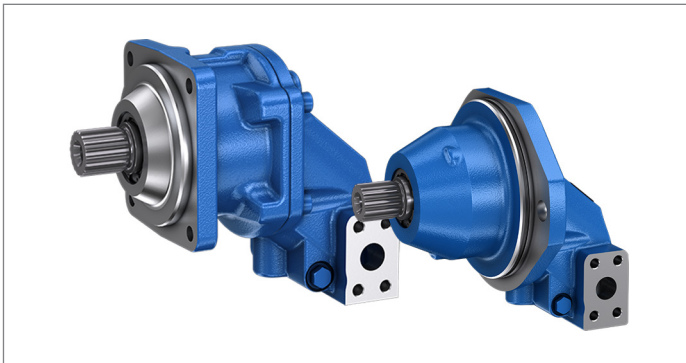

- ▶ A2FMN, A2FEN (sizes 28 to 107):
Nominal pressure 300 bar
Maximum pressure 350 bar
- ▶ A2FMM, A2FEM (sizes 23 to 180):
Nominal pressure 400 bar
Maximum pressure 450 bar
- ▶ A2FMH, A2FEH (sizes 45 to 125):
Nominal pressure 450 bar
Maximum pressure 500 bar

Features

- ▶ Fixed motor with axial tapered piston rotary group of bent-axis design, for hydrostatic drives in open and closed circuits
- ▶ For use in mobile and stationary applications
- ▶ Far-reaching integration of the plug-in version in mechanical gears due to recessed mounting flange located in the center of the case (extremely space-saving construction)
- ▶ Easy to install, simply plug the plug-in version into the mechanical gearbox
- ▶ The output speed depends on the flow of the pump and the displacement of the motor.
- ▶ The output torque increases with the pressure differential between the high-pressure side and the low-pressure side.
- ▶ Finely graduated sizes permit far-reaching adaptation to the drive concerned
- ▶ High power density
- ▶ Small dimensions
- ▶ High total efficiency
- ▶ Good starting efficiency
- ▶ Optional with integrated flushing valve

Contents

Type code	2
Hydraulic fluids	5
Working pressure range	6
Technical data	8
Dimensions A2FM, sizes 23 to 45	12
Dimensions A2FE, sizes 23 to 45	16
Drive shafts, sizes 23 to 45	20
Dimensions A2FM, sizes 45 to 80	21
Dimensions A2FE, sizes 45 to 80	26
Drive shafts, sizes 45 to 80	30
Dimensions A2FM, sizes 80 to 107	31
Dimensions A2FE, sizes 80 to 107	34
Drive shafts, sizes 80 to 107	37
Dimensions A2FM, sizes 107 and 125	38
Dimensions A2FE, sizes 107 and 125	41
Drive shafts, sizes 107 and 125	44
Dimensions A2FM, sizes 160 and 180	45
Dimensions A2FE, sizes 160 and 180	48
Drive shafts, sizes 160 and 180	51
Flushing and boost-pressure valve, integrated	52
Pressure relief valve	53
Counterbalance valve BVD/BVE	56
Port plate with integrated check valve (U)	60
Flow direction	60
Speed sensor	61
Installation instructions	62
Project planning notes	64
Safety instructions	64

Type code

01	02	03	04	05	06	07	08	09	10	11	12	13	14	15	
A2F				/	70	N	W	V						-	

Axial piston unit

01	Bent-axis design, fixed displacement	A2F
----	--------------------------------------	------------

Operating mode

02	Motor, standard version	M
	Motor, plug-in version	E

Pressure range

		023	028	032	037	045	056	063	080	090	107	125	160	180	
03	Nominal pressure: 300 bar, maximum pressure: 350 bar	-	●	●	●	●	●	●	●	●	●	-	-	-	N
	Nominal pressure: 400 bar, maximum pressure: 450 bar	●	●	●	-	●	●	●	●	●	●	●	●	●	M
	Nominal pressure: 450 bar, maximum pressure: 500 bar	-	-	-	-	●	●	●	●	●	●	●	-	-	H

Size (NG)

04	Geometrical displacement, See technical data on page 8	023	028	032	037	045	056	063	080	090	107	125	160	180
----	---	------------	------------	------------	------------	------------	------------	------------	------------	------------	------------	------------	------------	------------

Series

05	Series 7, index 0	70
----	-------------------	-----------

Version of port and fastening threads

06	Metric ports according to DIN 3852 with profile sealing ring, metric fastening thread according to DIN 13	N
----	---	----------

Direction of rotation

07	Viewed on drive shaft, bidirectional	W
----	--------------------------------------	----------

Sealing material

08	FKM (fluorocarbon rubber)	V
----	---------------------------	----------

Mounting flange

					023	028	032	037	045	056	063	080	090	107	125	160	180				
09	ISO 3019-2 metric	A2FM	100-4	●	●	●	●	● ¹⁾	-	-	-	-	-	-	-	-	-	-	L4		
			125-4	-	-	-	-	● ³⁾	●	●	● ¹⁾	-	-	-	-	-	-	-	-	M4	
			140-4	-	-	-	-	-	-	-	● ³⁾	●	● ¹⁾	-	-	-	-	-	-	-	N4
			160-4	-	-	-	-	-	-	-	-	-	-	● ³⁾	●	-	-	-	-	-	P4
			180-4	-	-	-	-	-	-	-	-	-	-	-	-	-	●	●	-	-	R4
	A2FE	135-2	●	●	●	●	● ¹⁾	-	-	-	-	-	-	-	-	-	-	-	-	I2	
		160-2	-	-	-	-	● ³⁾	●	●	● ¹⁾	-	-	-	-	-	-	-	-	-	P2	
		190-2	-	-	-	-	-	-	-	● ³⁾	●	● ¹⁾	-	-	-	-	-	-	-	Y2	
		200-2	-	-	-	-	-	-	-	-	-	-	● ³⁾	●	●	●	-	-	-	S2	

Drive shaft

					023	028	032	037	045	056	063	080	090	107	125	160	180			
10	Splined shaft DIN 5480	W25x1.25x18x9g	●	●	●	-	-	-	-	-	-	-	-	-	-	-	-	-	Z5	
		W30x2x14x9g	●	●	●	●	●	● ²⁾	-	-	-	-	-	-	-	-	-	-	-	Z6
		W35x2x16x9g	-	-	-	-	-	● ³⁾	●	● ²⁾	-	-	-	-	-	-	-	-	-	Z8
		W40x2x18x9g	-	-	-	-	-	-	-	● ³⁾	●	●	-	-	-	-	-	-	-	Z9
		W45x2x21x9g	-	-	-	-	-	-	-	-	-	-	-	● ³⁾	●	●	-	-	-	A1
		W50x2x24x9g	-	-	-	-	-	-	-	-	-	-	-	-	-	-	●	●	-	A2
	Parallel keyed shaft DIN 6885	ø25	●	●	●	-	-	-	-	-	-	-	-	-	-	-	-	-	-	P5
		ø30	●	●	●	●	●	● ²⁾	-	-	-	-	-	-	-	-	-	-	-	P6
		ø35	-	-	-	-	-	● ³⁾	●	● ²⁾	-	-	-	-	-	-	-	-	-	P8
		ø40	-	-	-	-	-	-	-	● ³⁾	●	●	-	-	-	-	-	-	-	P9
		ø45	-	-	-	-	-	-	-	-	-	-	-	● ³⁾	●	●	-	-	-	B1
		ø50	-	-	-	-	-	-	-	-	-	-	-	-	-	-	●	●	-	B2

01	02	03	04	05	06	07	08	09	10	11	12	13	14	15
A2F				/	70	N	W	V						-

Working port		023	028	032	037	045	056	063	080	090	107	125	160	180	
11	SAE working ports A and B at bottom	●	●	●	●	●	●	●	●	●	●	●	●	●	11
	SAE working ports A and B , 1× at side and 1× at bottom ¹⁾⁶⁾	-	-	-	-	-	●	●	●	-	-	-	-	-	12
	SAE working ports A and B at rear	● ³⁾	●	●	●	● ¹⁾	○	○	○	○	● ³⁾	●	●	●	01
	SAE working ports A and B at side, opposite	●	●	●	●	●	●	●	●	●	●	●	●	●	02
	Threaded ports A and B at side and at rear	●	●	●	●	○	○	○	○ ¹⁾	-	-	-	-	-	03
	Threaded ports A and B at side, opposite	●	●	●	●	● ¹⁾	-	-	-	-	-	-	-	-	05
	Version with pressure relief valves for mounting a counterbalance valve BVD20 ²⁾³⁾⁷⁾	-	-	-	-	●	●	●	●	●	●	●	-	-	07
	Version with pressure relief valves for mounting a counterbalance valve BVD/BVE25 ²⁾³⁾⁷⁾	-	-	-	-	-	-	-	-	-	●	●	-	-	08
	Version with pressure relief valves ²⁾³⁾⁸⁾	-	-	-	-	●	●	●	●	●	●	●	-	-	09

Valves		023	028	032	037	045	056	063	080	090	107	125	160	180		
12	Without valves	●	●	●	●	●	●	●	●	●	●	●	●	●	0	
	With check valve, only for counter-clockwise or clockwise direction of rotation ¹⁾	● ⁴⁾	● ⁴⁾	● ⁴⁾	● ⁴⁾	● ⁵⁾	● ⁵⁾	● ⁵⁾	● ⁵⁾	● ⁴⁾	● ⁴⁾	-	-	-	U	
	Integrated flushing and boost pressure valve Flushing flow when: $\Delta p = p_{ND} - p_G = 25 \text{ bar}$ and $v = 10 \text{ mm}^2/\text{s}$	Flushing flow [L/min] 2.6	●	●	●	●	●	●	●	●	●	-	-	-	-	C
		4.0	●	●	●	●	●	●	●	●	●	●	●	●	●	D
		6.0	●	●	●	●	●	●	●	●	●	●	●	●	●	E
		7.4	●	●	●	●	●	●	●	●	●	●	●	-	-	F
		8.5	●	●	●	●	●	●	●	●	●	●	●	●	●	G
		10.0	●	●	●	●	●	●	●	●	●	●	●	●	●	H
		11.4	●	●	●	●	●	●	●	●	●	-	-	●	●	I
		12.5	●	●	●	●	●	●	●	●	●	-	-	●	●	J
		15	-	-	-	-	-	-	-	-	-	● ³⁾	●	●	●	K
		18	-	-	-	-	-	-	-	-	-	● ³⁾	●	●	●	L
	21	-	-	-	-	-	-	-	-	-	● ³⁾	●	●	●	M	
	27	-	-	-	-	-	-	-	-	-	● ³⁾	●	●	●	N	
	31	-	-	-	-	-	-	-	-	-	● ³⁾	●	●	●	O	
	37	-	-	-	-	-	-	-	-	-	● ³⁾	●	●	●	P	
Pressure relief valves (without pressure sequencing stage) ²⁾³⁾⁹⁾	-	-	-	-	●	●	●	●	●	●	●	-	-	R		
Pressure-relief valves (with pressure sequencing stage) ²⁾³⁾⁹⁾	-	-	-	-	●	●	●	●	●	●	●	-	-	S		
Counterbalance valve BVD/BVE mounted ²⁾³⁾¹⁰⁾¹¹⁾	-	-	-	-	●	●	●	●	●	●	●	●	-	-	W	

<p>1) Only available for A2FMN, A2FEN (pressure range 300 to 350 bar)</p> <p>2) Not available for A2FMH, A2FEH (pressure range 450 to 500 bar)</p> <p>3) Not available for A2FMN, A2FEN (pressure range 300 to 350 bar)</p> <p>4) Only in combination with working ports 11</p> <p>5) Only in combination with working ports 11 or 12</p> <p>6) Only in combination with check valve (valve design U)</p>	<p>7) Only in combination with mounted counterbalance valve (valve design W)</p> <p>8) Only in combination with pressure relief valve (valve designs R or S)</p> <p>9) Only in combination with working ports 09</p> <p>10) Only in combination with working ports 07 or 08</p> <p>11) Type code for counterbalance valve to be quoted separately in accordance with data sheet 95522 (BVD) and 95526 (BVE)</p>
---	---

4 **A2FM/A2FE series 70** | Axial piston fixed motor
Type code

01	02	03	04	05	06	07	08	09	10	11	12	13	14	15
A2F				/	70	N	W	V						-

Speed sensor		023	028	032	037	045	056	063	080	090	107	125	160	180	
13	Without speed sensor	•	•	•	•	•	•	•	•	•	•	•	•	•	0
	Prepared for DSA sensor	•	•	•	•	•	•	•	•	•	•	•	•	•	A
	DSA speed sensor mounted	•	•	•	•	•	•	•	•	•	•	•	•	•	B

Special version		023	028	032	037	045	056	063	080	090	107	125	160	180	
14	Standard version	•	•	•	•	•	•	•	•	•	•	•	•	•	0
	Long-life bearing ¹²⁾¹³⁾	•	•	•	•	•	•	•	•	•	•	•	•	•	L
	Special version for slew drives ¹⁴⁾	•	•	•	•	•	•	•	•	•	•	•	•	•	J

Standard/special version		023	028	032	037	045	056	063	080	090	107	125	160	180	
15	Standard version														0
	Standard version with installation variants, e.g. T ports contrary to standard, open or closed														Y
	Special version														S

• = Available ◦ = On request - = Not available

Notice

- ▶ Note the project planning notes on page 64.
- ▶ Please note that not all type code combinations are available although the individual functions are marked as being available.

¹²⁾ Type code version "L" not available in combination with A2FMH/A2FEH since in the case of pressure range "H" the long-life bearing is already included in the standard version (type code designation "0").

¹³⁾ Not for NG 23 to 37 and 45 (N)

¹⁴⁾ Not available for A2FMN, A2FEN (pressure range 300 to 350 bar)

Hydraulic fluids

The fixed motor A2FM/A2FE is designed for operation with HLP mineral oil according to DIN 51524.

Application instructions and requirements for hydraulic fluid selection, behavior during operation as well as disposal and environmental protection should be taken from the following data sheets before the start of project planning:

- ▶ 90220: Hydraulic fluids based on mineral oils and related hydrocarbons
- ▶ 90221: Environmentally acceptable hydraulic fluids

Selection of hydraulic fluid

Bosch Rexroth evaluates hydraulic fluids on the basis of the Fluid Rating according to the technical data sheet 90235.

Hydraulic fluids with positive evaluation in the Fluid Rating are provided in the following technical data sheet:

- ▶ 90245: Bosch Rexroth Fluid Rating List for Rexroth hydraulic components (pumps and motors)

Selection of hydraulic fluid shall make sure that the operating viscosity in the operating temperature range is within the optimum range (v_{opt} ; see selection diagram).

Notice

For operation with HF hydraulic fluids, please contact us.

Viscosity and temperature of hydraulic fluids

	Viscosity	Shaft seal	Temperature ³⁾	Remarks
Cold start	$v_{max} \leq 1600 \text{ mm}^2/\text{s}$	NBR ²⁾	$\vartheta_{st} \geq -40 \text{ }^\circ\text{C}$	$t \leq 3 \text{ min}$, without load $p \leq 50 \text{ bar}$, $n \leq 1000 \text{ rpm}$ Permissible temperature difference between axial piston unit and hydraulic fluid in the system maximum 25 K
		FKM	$\vartheta_{st} \geq -25 \text{ }^\circ\text{C}$	
Warm-up phase	$v = 1600 \dots 400 \text{ mm}^2/\text{s}$			$t \leq 15 \text{ min}$, $p \leq 0.7 \times p_{nom}$ and $n \leq 0.5 \times n_{nom}$
Continuous operation	$v = 400 \dots 10 \text{ mm}^2/\text{s}^{1)}$	NBR ²⁾	$\vartheta \leq +78 \text{ }^\circ\text{C}$	Measured at port T
		FKM	$\vartheta \leq +103 \text{ }^\circ\text{C}$	
		$v_{opt} = 36 \dots 16 \text{ mm}^2/\text{s}$		
Short-term operation	$v_{min} = 10 \dots 7 \text{ mm}^2/\text{s}$	NBR ²⁾	$\vartheta \leq +78 \text{ }^\circ\text{C}$	$t \leq 3 \text{ min}$, $p \leq 0.3 \times p_{nom}$, measured at port T
		FKM	$\vartheta \leq +103 \text{ }^\circ\text{C}$	

Notice: The maximum circuit temperature of +115 °C must not be exceeded at the working ports **A** and **B** complying with the permissible viscosity.

▼ Selection diagram

Maximum permissible viscosity on cold start

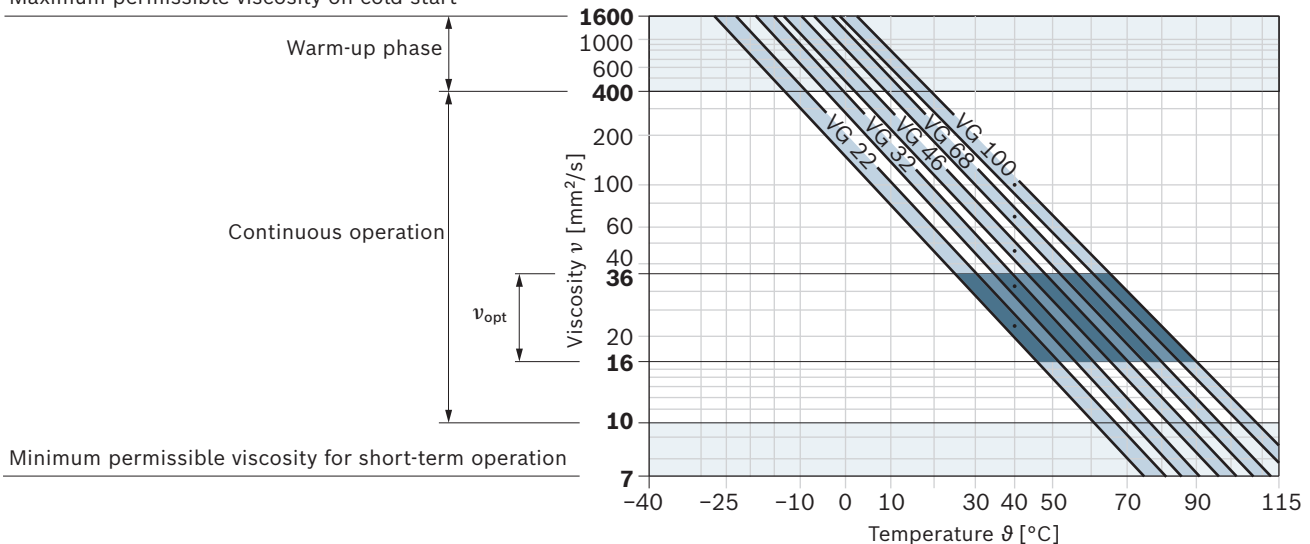

1) This corresponds, for example on the VG 46, to a temperature range of +4 °C to +85 °C (see selection diagram)

2) Special version, please contact us

3) If the temperature at extreme operating parameters cannot be adhered to, please contact us.

Filtration of the hydraulic fluid

Finer filtration improves the cleanliness level of the hydraulic fluid, which increases the service life of the axial piston unit.

A cleanliness level of at least 20/18/15 is to be maintained according to ISO 4406.

At a hydraulic fluid viscosity of less than 10 mm²/s (e.g. due to high temperatures during short-term operation), a cleanliness level of at least 19/17/14 under ISO 4406 is required.

For example, the viscosity 10 mm²/s at:

- ▶ HLP 32 a temperature of 73 °C
- ▶ HLP 46 a temperature of 85 °C

Flow direction

Direction of rotation, viewed on drive shaft	
clockwise	counter-clockwise
A to B	B to A

Working pressure range

Pressure at working port A or B		Definition	
Nominal pressure p_{nom}	A2FMN, A2FEN	300 bar	The nominal pressure corresponds to the maximum design pressure.
	A2FMM, A2FEM	400 bar	
	A2FMH, A2FEH	450 bar	
Maximum pressure p_{max}	A2FMN, A2FEN	350 bar	The maximum pressure corresponds to the maximum working pressure within a single operating period. The sum of single operating periods must not exceed the total operating period.
	A2FMM, A2FEM	450 bar	
	A2FMH, A2FEH	500 bar	
	Maximum single operating period	10 s	
	Total operating period	300 h	
Minimum pressure – pump operating mode (inlet)	See the diagram (next page)		To prevent damage to the axial piston motor during operation as a pump (change of the high-pressure side with constant direction of rotation, e.g. during brake applications) a minimum pressure has to be ensured at the working port (inlet). The minimum pressure depends on the rotational speed and displacement of the axial piston unit.
Summation pressure p_{Su}		700 bar	The summation pressure is the sum of the pressures at the ports for the working lines (A and B).
Rate of pressure change $R_{A\ max}$	with integrated pressure relief valve	9000 bar/s	Maximum permissible pressure build-up and reduction speed during a pressure change across the entire pressure range.
	without pressure relief valve	16000 bar/s	
Case pressure at port T			
Continuous differential pressure $\Delta p_{T\ cont}$		2 bar	Maximum averaged differential pressure at the shaft seal (case to ambient pressure)
Pressure peaks $p_{T\ peak}$		10 bar	$t < 0.1\ s$

▼ **Rate of pressure change $R_{A \max}$**

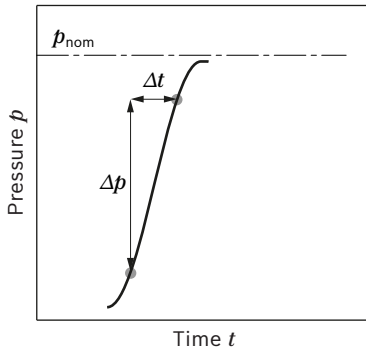

▼ **Minimum pressure – pump operating mode (inlet)**

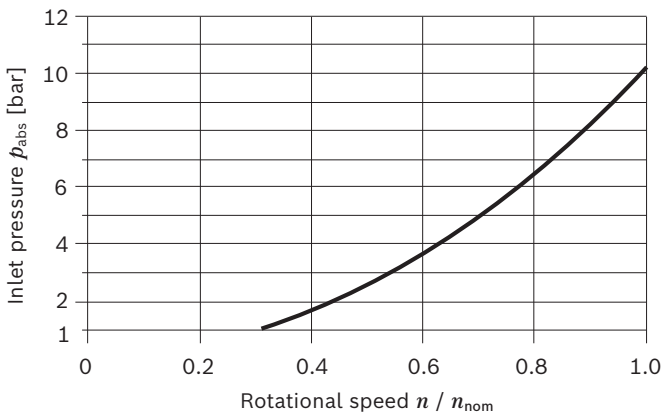

This diagram is only valid for the optimum viscosity range of $\nu_{\text{opt}} = 36$ bis $16 \text{ mm}^2/\text{s}$.

If the above-mentioned conditions cannot be ensured, please contact us.

▼ **Pressure definition**

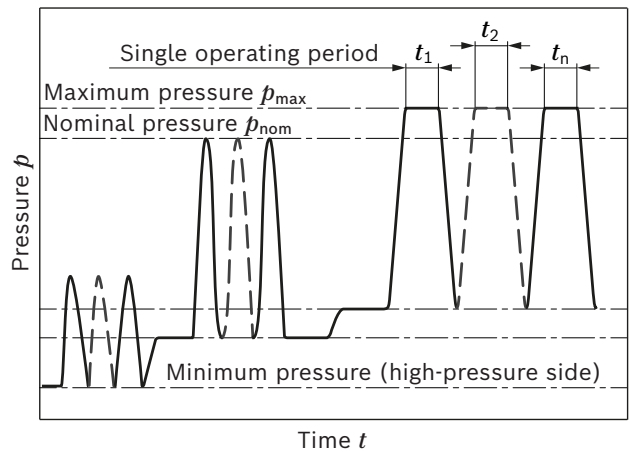

Total operating period = $t_1 + t_2 + \dots + t_n$

Notice

- ▶ Working pressure range applies when using hydraulic fluids based on mineral oils. Please contact us for values for other hydraulic fluids.
- ▶ In addition to the hydraulic fluid and the temperature, the service life of the shaft seal is influenced by the rotational speed of the axial piston unit and the case pressure.
- ▶ The service life of the shaft seal decreases with increasing frequency of pressure peaks and increasing mean differential pressure.
- ▶ The case pressure must be greater than the external pressure (ambient pressure) at the shaft seal.

Technical data

A2FMN, A2FEN

Size	NG		28	32	37	45	56	63	80	90	107		
Displacement, geometrical, per revolution	V_g	cm ³	28.1	32.0	36.8	44.2	56.6	63.0	81.7	90.5	108.8		
Maximum rotational speed ¹⁾	n_{nom}	rpm	4725	4725	4200	4200	3750	3750	3375	3375	3000		
	$n_{max}^{2)}$	rpm	5175	5175	4650	4650	4125	4125	3700	3700	3300		
Inlet flow	at n_{nom}	$q_{v max}$	l/min	133	151	155	186	212	236	276	305	326	
Torque ³⁾	at $\Delta p = 300$ bar	M	Nm	134	153	176	211	270	301	390	432	519	
Rotary stiffness		c_{min}	kNm/rad	2.20	2.46	4.29	4.84	6.97	8.11	8.47	9.85	10.96	
Moment of inertia of the rotary group		J_{TW}	kgm ²	0.0010	0.0011	0.0012	0.0012	0.0034	0.0035	0.0037	0.0058	0.0061	
Case volume		V	l	0.3	0.3	0.3	0.3	0.6	0.6	0.6	0.65	0.65	
Weight approx.		m	kg	10.7	10.7	10.7	10.7	17	17	17	23	23	

A2FMM, A2FEM

Size	NG		23	28	32	45	56	63	80	90	107	125	160	180
Displacement, geometrical, per revolution	V_g	cm ³	22.9	28.1	32.0	44.9	56.6	63.0	79.8	90.5	106.7	125.0	160.4	180.0
Maximum rotational speed ¹⁾	n_{nom}	rpm	6300	6300	6300	5000	5000	5000	4500	4500	4000	4000	3600	3600
	$n_{max}^{2)}$	rpm	6900	6900	6900	5500	5500	5500	5000	5000	4400	4400	4000	4000
Inlet flow	at n_{nom}	$q_{v max}$	l/min	144	177	202	225	283	315	359	407	427	500	577
Torque ³⁾	at $\Delta p = 400$ bar	M	Nm	146	179	204	286	360	401	508	576	679	796	1021
Rotary stiffness		c_{min}	kNm/rad	1.76	2.20	2.46	4.65	6.97	8.11	9.10	9.85	12.49	13.65	21.32
Moment of inertia of the rotary group		J_{TW}	kgm ²	0.0010	0.0010	0.0011	0.0033	0.0034	0.0035	0.0056	0.0058	0.0088	0.0091	0.0248
Case volume		V	l	0.3	0.3	0.3	0.6	0.6	0.6	0.65	0.65	1.1	1.1	0.8
Weight approx.		m	kg	10.7	10.7	10.7	17	17	17	23	23	32.8	32.8	41

A2FMH, A2FEH

Size	NG		45	56	63	80	90	107	125				
Displacement, geometrical, per revolution	V_g	cm ³	44.9	56.6	63.0	79.8	90.5	106.7	125.0				
Maximum rotational speed ¹⁾	n_{nom}	rpm	5000	5000	5000	4500	4500	4000	4000				
	$n_{max}^{2)}$	rpm	5500	5500	5500	5000	5000	4400	4400				
Inlet flow	at n_{nom}	$q_{v max}$	l/min	225	283	315	359	407	427	500			
Torque ³⁾	at $\Delta p = 450$ bar	M	Nm	322	405	451	572	648	764	895			
Rotary stiffness		c_{min}	kNm/rad	4.65	6.97	8.11	9.10	9.85	12.49	13.65			
Moment of inertia of the rotary group		J_{TW}	kgm ²	0.0033	0.0034	0.0035	0.0056	0.0058	0.0088	0.0091			
Case volume		V	l	0.6	0.6	0.6	0.65	0.65	1.1	1.1			
Weight approx.		m	kg	17	17	17	23	23	32.8	32.8			

Speed range

No limit to minimum speed n_{min} . If uniformity of motion is required, rotational speed n_{min} must not be less than 50 rpm.

1) The valid values (observing the maximum permissible inlet flow):
 – for the optimum viscosity range from $\nu_{opt} = 36$ to 16 mm²/s
 – with hydraulic fluid based on mineral oils

2) Intermittent maximum speed: Overspeed for unload and overhauling processes, $t < 5$ s and $\Delta p < 150$ bar
 3) Torque without radial force, with radial force see page 11

Determination of the characteristics			
Inlet flow	q_v	$= \frac{V_g \times n}{1000 \times \eta_v}$	[l/min]
Rotational speed	n	$= \frac{q_v \times 1000 \times \eta_v}{V_g}$	[rpm]
Torque	M	$= \frac{V_g \times \Delta p \times \eta_{mh}}{20 \times \pi}$	[Nm]
Power	P	$= \frac{2 \pi \times M \times n}{60000} = \frac{q_v \times \Delta p \times \eta_t}{600}$	[kW]

Key

- V_g Displacement per revolution [cm³]
- Δp Differential pressure [bar]
- n Rotational speed [rpm]
- η_v Volumetric efficiency
- η_{mh} Hydraulic-mechanical efficiency
- η_t Total efficiency ($\eta_t = \eta_v \times \eta_{mh}$)

Notice

- ▶ Theoretical values, without efficiency and tolerances; values rounded
- ▶ Operation above the maximum values or below the minimum values may result in a loss of function, a reduced service life or in the destruction of the axial piston unit. Other permissible limit values, such as speed variation, reduced angular acceleration as a function of the frequency and the permissible angular acceleration at start (lower than the maximum angular acceleration) can be found in data sheet 90261.

Permissible radial and axial loading on the drive shafts

A2FMN, A2FEN

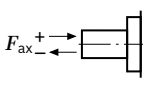
Size	NG		28	28	32	32	37	45	56	63	80	90	107	
Drive shaft	Code		Z5/P5	Z6/P6	Z5/P5	Z6/P6	Z6/P6	Z6/P6	Z6/P6	Z8/P8	Z8/P8	Z9/P9	Z9/P9	
	with splined shaft	\varnothing	mm	25	30	25	30	30	30	30	35	35	40	40
	with keyed shaft	\varnothing	mm	25	30	25	30	30	30	30	35	35	40	40
Maximum radial force ¹⁾ at distance a (to the shaft collar)		$F_{q \max}$	kN	4.3	3.6	4.9	4.1	4.7	5.6	7.2	6.9	8.9	8.6	10.4
		a	mm	16	16	16	16	16	16	18	18	18	20	20
Maximum torque at $F_{q \max}$	$M_{q \max}$	Nm	134	134	153	153	176	211	270	301	390	432	519	
Maximum differential pressure at $F_{q \max}$	$\Delta p_{q \max}$	bar	300	300	300	300	300	300	300	300	300	300	300	
Maximum axial force at standstill or depressurized operation		$+ F_{ax \max}$	N	0	0	0	0	0	0	0	0	0	0	
		$- F_{ax \max}$	N	500	500	500	500	500	500	800	800	800	1000	1000
Permissible axial force per bar working pressure	$+ F_{ax \text{ perm}}/\text{bar}$	N/bar	5.2	5.2	5.2	5.2	5.2	5.2	8.7	8.7	8.7	10.6	10.6	

A2FMM, A2FEM

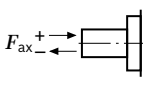
Size	NG		23	23	28	28	32	32	45	56	56	63	
Drive shaft	Code		Z5/P5	Z6/P6	Z5/P5	Z6/P6	Z5/P5	Z6/P6	Z6/P6	Z6/P6	Z8/P8	Z8/P8	
	with splined shaft	\varnothing	mm	25	30	25	30	25	30	30	30	35	35
	with keyed shaft	\varnothing	mm	25	30	25	30	25	30	30	30	35	35
Maximum radial force ¹⁾ at distance a (to the shaft collar)		$F_{q \max}$	kN	4.7	3.9	5.7	4.8	6.5	5.4	7.6	9.6	8.2	9.2
		a	mm	16	16	16	16	16	16	18	18	18	18
Maximum torque at $F_{q \max}$	$M_{q \max}$	Nm	146	146	179	179	204	204	286	360	360	401	
Maximum differential pressure at $F_{q \max}$	$\Delta p_{q \max}$	bar	400	400	400	400	400	400	400	400	400	400	
Maximum axial force at standstill or depressurized operation		$+ F_{ax \max}$	N	0	0	0	0	0	0	0	0	0	
		$- F_{ax \max}$	N	500	500	500	500	500	500	800	800	800	800
Permissible axial force per bar working pressure	$+ F_{ax \text{ perm}}/\text{bar}$	N/bar	5.2	5.2	5.2	5.2	5.2	5.2	8.7	8.7	8.7	8.7	

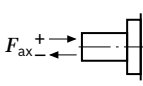
Size	NG		80	80	90	107	107	125	160	160	180	
Drive shaft	Code		Z8/P8	Z9/P9	Z9/P9	Z9/P9	A1/B1	A1/B1	A1/B1	A2/B2	A2/B2	
	with splined shaft	\varnothing	mm	35	40	40	40	45	45	45	50	50
	with keyed shaft	\varnothing	mm	35	40	40	40	45	45	45	50	50
Maximum radial force ¹⁾ at distance a (to the shaft collar)		$F_{q \max}$	kN	11.6	10.2	11.5	13.6	12.1	14.1	18.2	16.3	18.3
		a	mm	20	20	20	20	20	20	25	25	25
Maximum torque at $F_{q \max}$	$M_{q \max}$	Nm	508	508	576	679	679	796	1021	1021	1146	
Maximum differential pressure at $F_{q \max}$	$\Delta p_{q \max}$	bar	400	400	400	400	400	400	400	400	400	
Maximum axial force at standstill or depressurized operation		$+ F_{ax \max}$	N	0	0	0	0	0	0	0	0	
		$- F_{ax \max}$	N	1000	1000	1000	1250	1250	1250	1600	1600	1600
Permissible axial force per bar working pressure	$+ F_{ax \text{ perm}}/\text{bar}$	N/bar	10.6	10.6	10.6	12.9	12.9	12.9	16.7	16.7	16.7	

1) With intermittent operation

Permissible radial and axial loading on the drive shafts

A2FMH, A2FEH

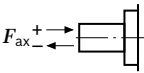
Size	NG		45	56	63	80	90	107	107	125	
Drive shaft	Code		Z6/P6	Z8/P8	Z8/P8	Z9/P9	Z9/P9	Z9/P9	A1/B1	A1/B1	
	with splined shaft	\varnothing	mm	30	35	35	40	40	40	45	45
	with keyed shaft	\varnothing	mm	30	35	35	40	40	40	45	45
Maximum radial force ¹⁾ at distance a (to the shaft collar)		$F_{q \max}$	kN	8.6	9.3	10.3	11.4	13.0	15.3	13.6	15.9
		a	mm	18	18	18	20	20	20	20	20
Maximum torque at $F_{q \max}$	$M_{q \max}$	Nm	322	405	451	572	648	764	764	895	
Maximum differential pressure at $F_{q \max}$	$\Delta p_{q \max}$	bar	450	450	450	450	450	450	450	450	
Maximum axial force at standstill or depressurized operation		$+ F_{ax \max}$	N	0	0	0	0	0	0	0	
		$- F_{ax \max}$	N	800	800	800	1000	1000	1250	1250	1250
Permissible axial force per bar working pressure	$+ F_{ax \text{ perm}/\text{bar}}$	N/bar	8.7	8.7	8.7	10.6	10.6	12.9	12.9	12.9	

Effect of radial force F_q on bearing service life

By selecting a suitable direction of radial force F_q , the load on the bearings, caused by the internal rotary group forces can be reduced, thus optimizing the bearing service life. Recommended position of mating gear is dependent on the direction of rotation. Examples:

▼ Gear output drive

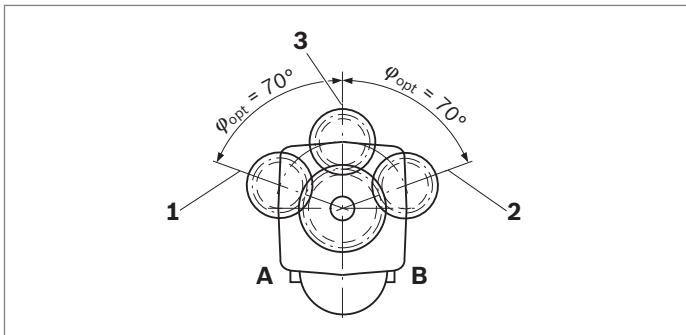

1 "Counter-clockwise" rotational direction, pressure at port B

2 "Clockwise" rotational direction, pressure at port A

3 "Bidirectional" direction of rotation

Notice

- ▶ The values given are maximum values and do not apply to continuous operation.
- ▶ The permissible axial force in direction $-F_{ax}$ is to be avoided as the service life of the bearing is reduced.
- ▶ Special requirements apply in the case of belt output drives. Please contact us.

1) With intermittent operation

Dimensions A2FM, sizes 23 to 45

SAE working ports A and B at bottom (11)

A2FMN sizes 28, 32, 37 and 45

A2FMM sizes 23, 28 and 32

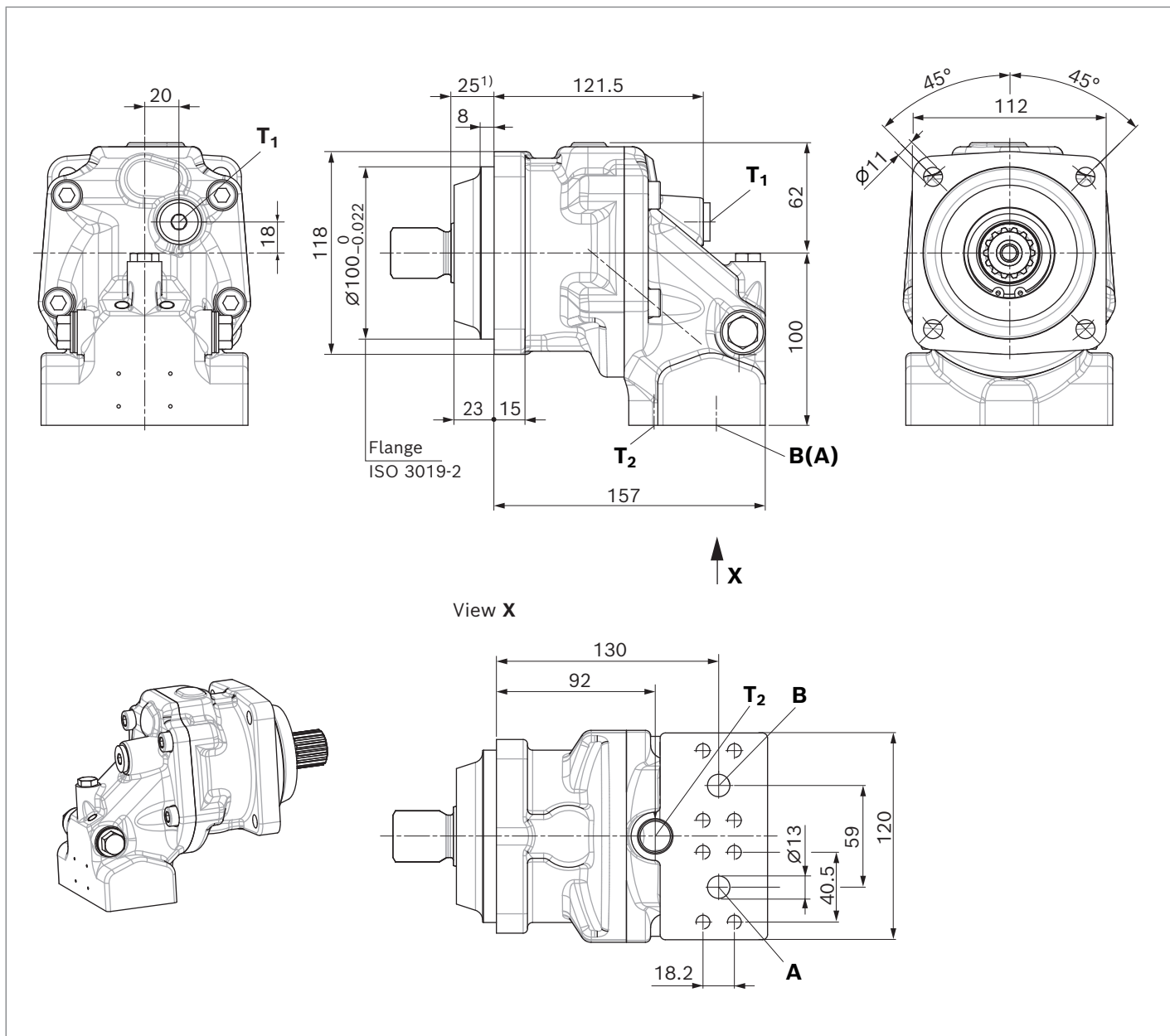

Ports	Standard	Size	p_{max} [bar] ²⁾	State ⁵⁾	
A, B	Working port Fastening thread A/B	SAE J518 DIN 13	1/2 in M8 × 1.25; 16 deep	450	O
T₁	Drain port	DIN 3852 ⁴⁾	M16 × 1.5; 12 deep	3	X ³⁾
T₂	Drain port	DIN 3852 ⁴⁾	M16 × 1.5; 12 deep	3	O ³⁾

1) To shaft collar

2) Depending on the application, momentary pressure peaks can occur. Keep this in mind when selecting measuring devices and fittings.

3) Depending on installation position, T₁ or T₂ must be connected (see also installation instructions on page 62).

4) The countersink may be deeper than specified in the standard.

5) O = Must be connected (plugged on delivery)

X = Plugged (in normal operation)

SAE working ports A and B at rear (01)

A2FMN sizes 28, 32, 37 and 45

A2FMM sizes 23, 28 and 32

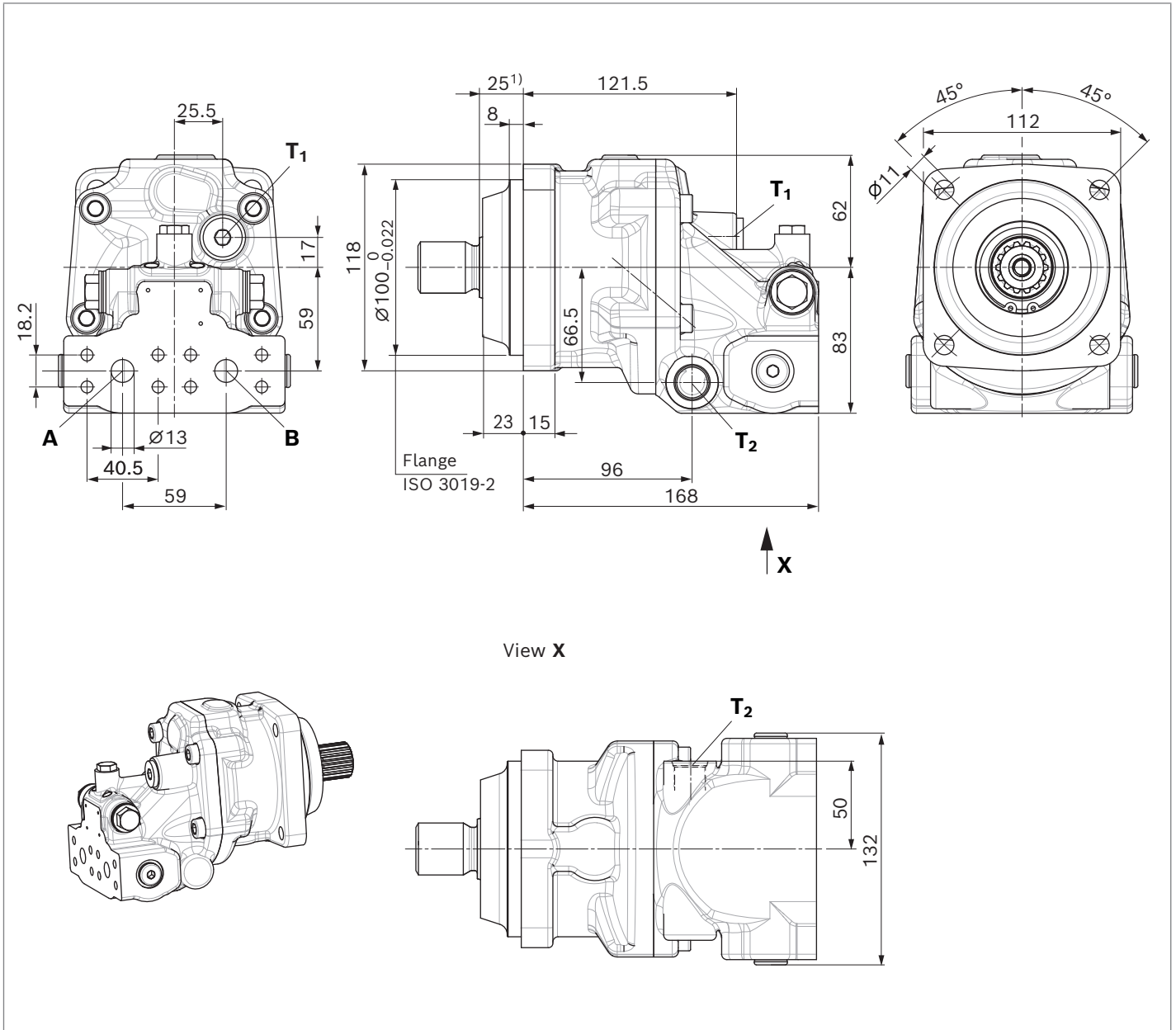

Ports		Standard	Size	p_{max} [bar] ²⁾	State ⁵⁾
A, B	Working port	SAE J518	1/2 in	450	O
	Fastening thread A/B	DIN 13	M8 × 1.25; 16 deep		
T₁	Drain port	DIN 3852 ⁴⁾	M16 × 1.5; 12 deep	3	X ³⁾
T₂	Drain port	DIN 3852 ⁴⁾	M16 × 1.5; 12 deep	3	O ³⁾

1) To shaft collar

2) Depending on the application, momentary pressure peaks can occur. Keep this in mind when selecting measuring devices and fittings.

3) Depending on installation position, T₁ or T₂ must be connected (see also installation instructions on page 62).

4) The countersink may be deeper than specified in the standard.

5) O = Must be connected (plugged on delivery)

X = Plugged (in normal operation)

SAE working ports A and B at side, opposite (02)

A2FMN sizes 28, 32, 37 and 45

A2FMM sizes 23, 28 and 32

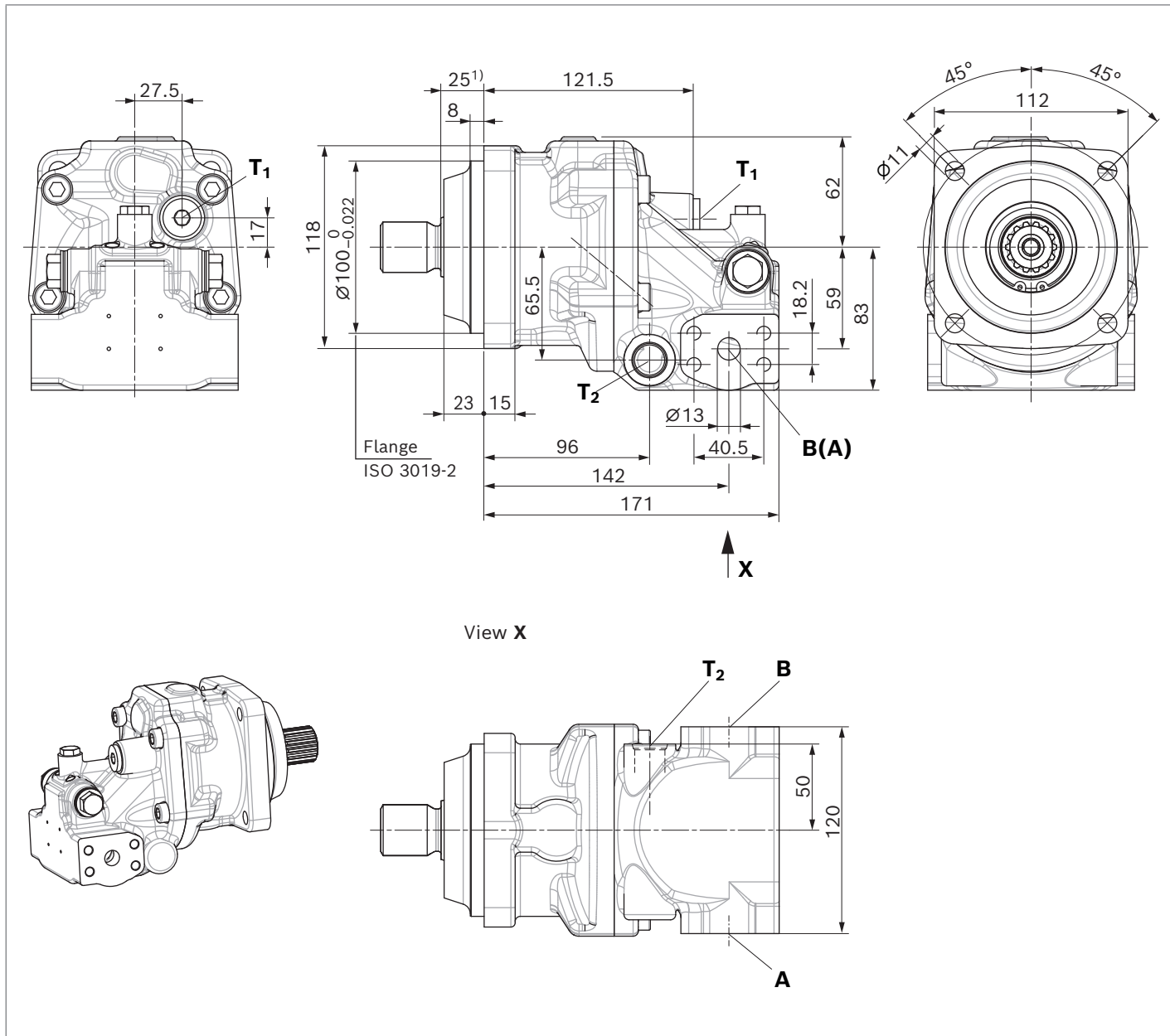

Ports		Standard	Size	p_{max} [bar] ²⁾	State ⁵⁾
A, B	Working port Fastening thread A/B	SAE J518 DIN 13	1/2 in M8 × 1.25; 16 deep	450	O
T₁	Drain port	DIN 3852 ⁴⁾	M16 × 1.5; 12 deep	3	X ³⁾
T₂	Drain port	DIN 3852 ⁴⁾	M16 × 1.5; 12 deep	3	O ³⁾

1) To shaft collar

2) Depending on the application, momentary pressure peaks can occur. Keep this in mind when selecting measuring devices and fittings.

3) Depending on installation position, T₁ or T₂ must be connected (see also installation instructions on page 62).

4) The countersink may be deeper than specified in the standard.

5) O = Must be connected (plugged on delivery)

X = Plugged (in normal operation)

Threaded ports A and B at side, opposite (05)

A2FMN sizes 28, 32, 37 and 45

A2FMM sizes 23, 28 and 32

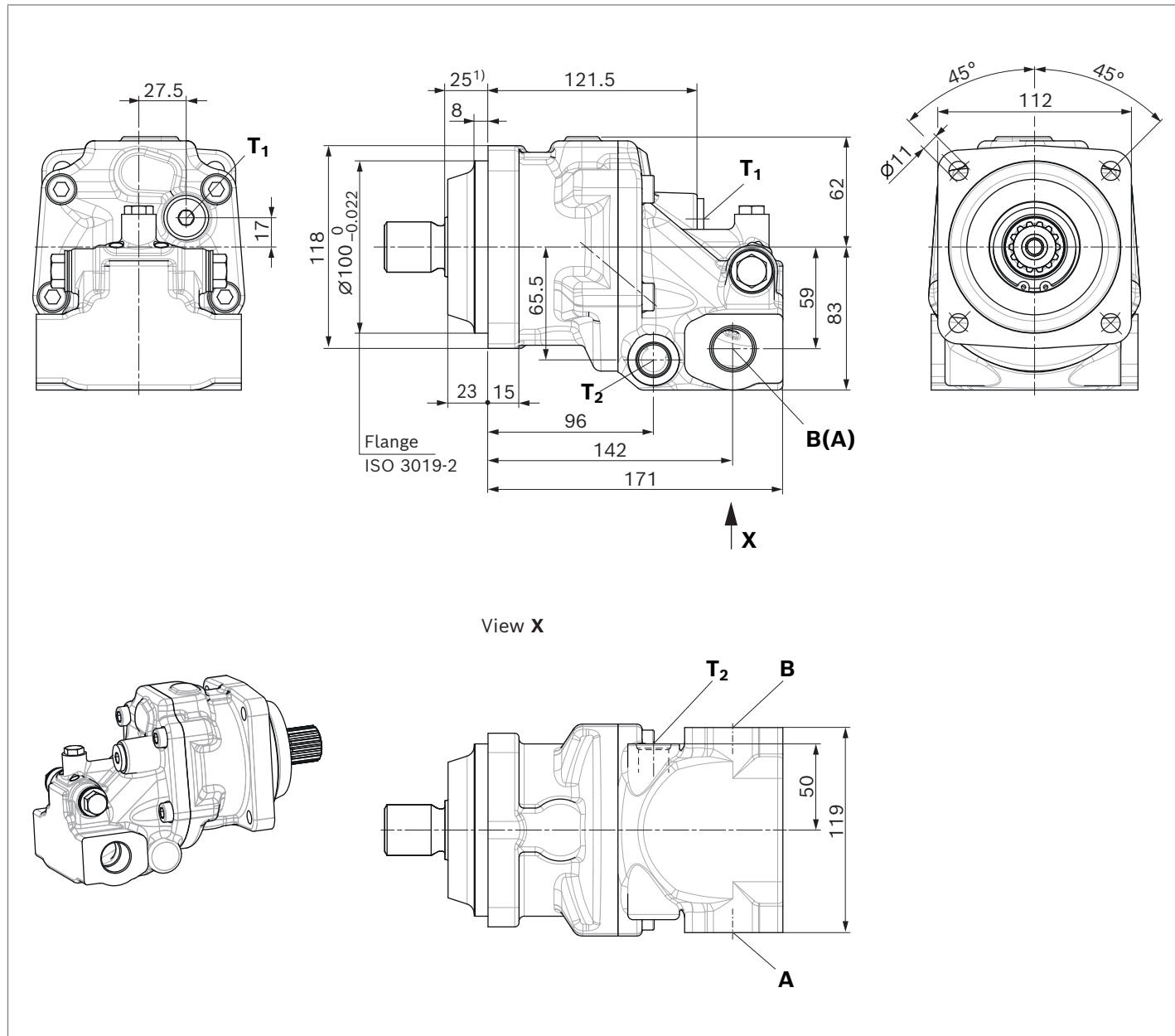

View X

Ports		Standard	Size	p_{max} [bar] ²⁾	State ⁵⁾
A, B	Working port	DIN 3852 ⁴⁾	M27 × 2; 16 deep	450	O
T₁	Drain port	DIN 3852 ⁴⁾	M16 × 1.5; 12 deep	3	X ³⁾
T₂	Drain port	DIN 3852 ⁴⁾	M16 × 1.5; 12 deep	3	O ³⁾

1) To shaft collar
 2) Depending on the application, momentary pressure peaks can occur. Keep this in mind when selecting measuring devices and fittings.
 3) Depending on installation position, T₁ or T₂ must be connected (see also installation instructions on page 62).

4) The countersink may be deeper than specified in the standard.
 5) O = Must be connected (plugged on delivery)
 X = Plugged (in normal operation)

Dimensions A2FE, sizes 23 to 45

SAE working ports A and B at bottom (11)

A2FEN sizes 28, 32, 37 and 45

A2FEM sizes 23, 28 and 32

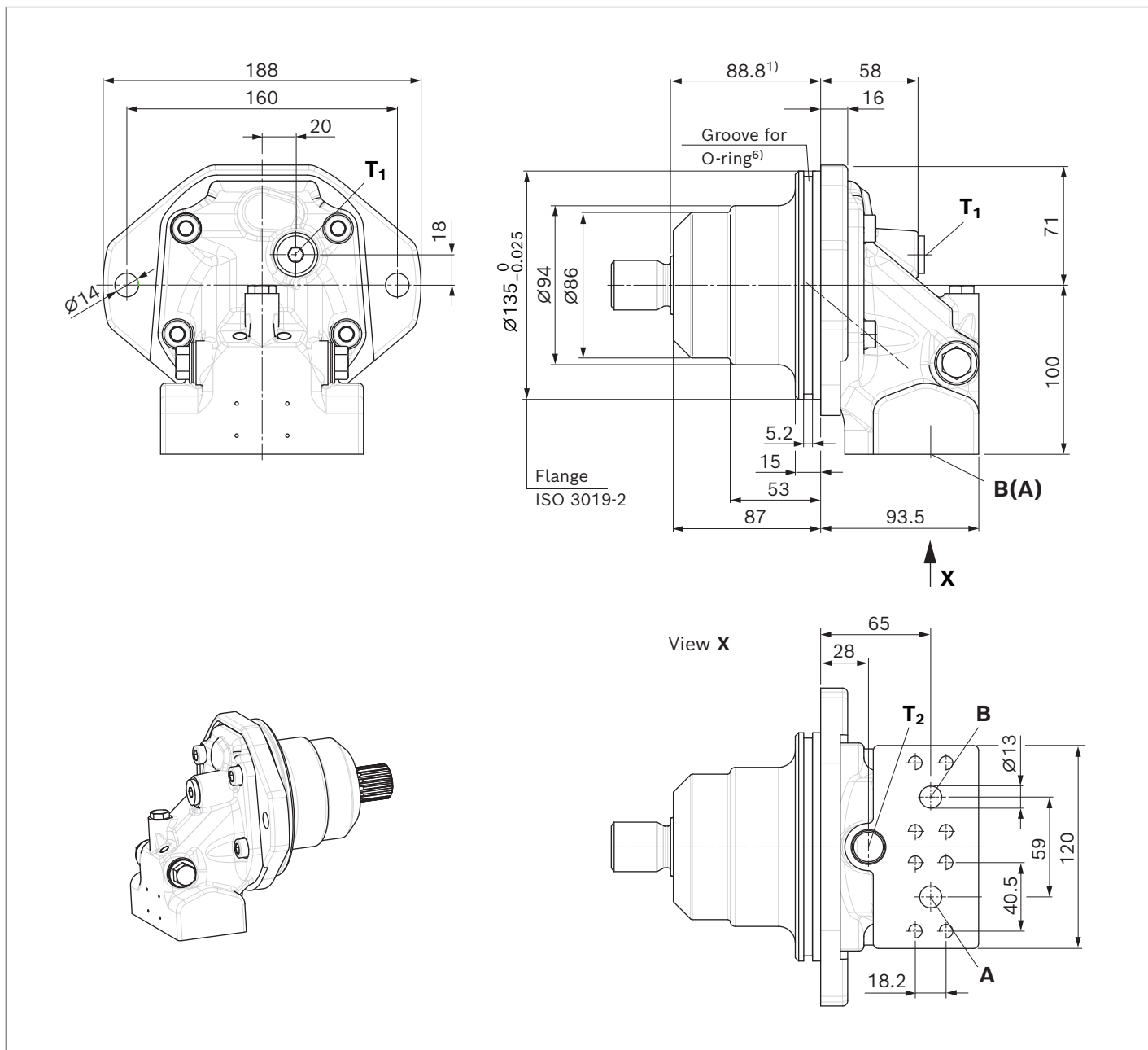

Ports	Standard	Size	p_{max} [bar] ²⁾	State ⁵⁾
A, B	Working port Fastening thread A/B	SAE J518 DIN 13	1/2 in M8 × 1.25; 16 deep	450 O
T ₁	Drain port	DIN 3852 ⁴⁾	M16 × 1.5; 12 deep	3 X ³⁾
T ₂	Drain port	DIN 3852 ⁴⁾	M16 × 1.5; 12 deep	3 O ³⁾

1) To shaft collar

2) Depending on the application, momentary pressure peaks can occur. Keep this in mind when selecting measuring devices and fittings.

3) Depending on installation position, T₁ or T₂ must be connected (see also installation instructions on page 62).

4) The countersink may be deeper than specified in the standard.

5) O = Must be connected (plugged on delivery)

X = Plugged (in normal operation)

6) O-ring Ø126 × 4 not included in the scope of delivery

SAE working ports A and B at rear (01)

A2FEN sizes 28, 32, 37 and 45

A2FEM sizes 23, 28 and 32

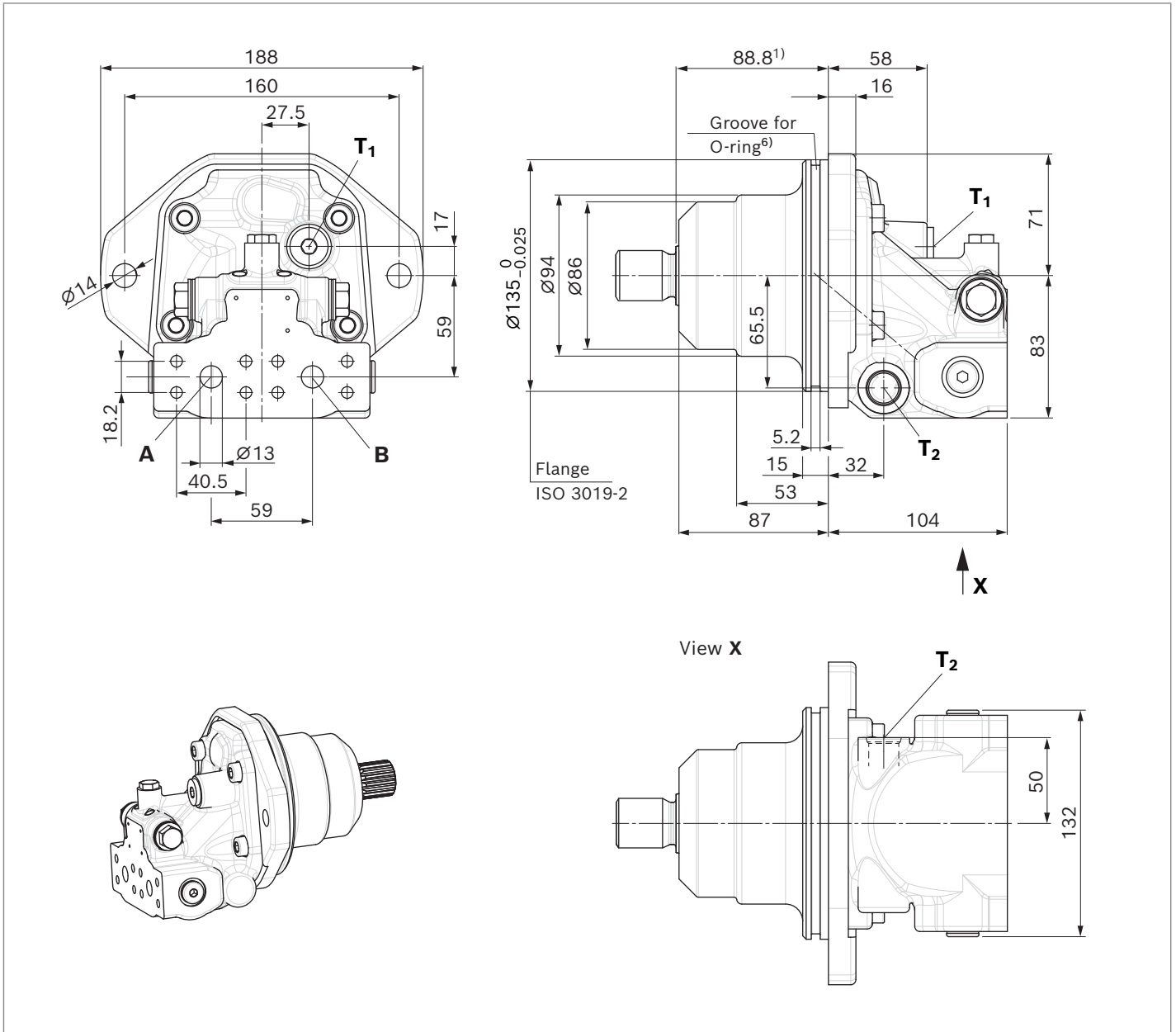

Ports		Standard	Size	p_{max} [bar] ²⁾	State ⁵⁾
A, B	Working port	SAE J518	1/2 in	450	O
	Fastening thread A/B	DIN 13	M8 × 1.25; 16 deep		
T₁	Drain port	DIN 3852 ⁴⁾	M16 × 1.5; 12 deep	3	X ³⁾
T₂	Drain port	DIN 3852 ⁴⁾	M16 × 1.5; 12 deep	3	O ³⁾

1) To shaft collar

2) Depending on the application, momentary pressure peaks can occur. Keep this in mind when selecting measuring devices and fittings.

3) Depending on installation position, T₁ or T₂ must be connected (see also installation instructions on page 62).

4) The countersink may be deeper than specified in the standard.

5) O = Must be connected (plugged on delivery)

X = Plugged (in normal operation)

6) O-ring Ø126 × 4 not included in the scope of delivery

SAE working ports A and B at side, opposite (02)

A2FEN sizes 28, 32, 37 and 45

A2FEM sizes 23, 28 and 32

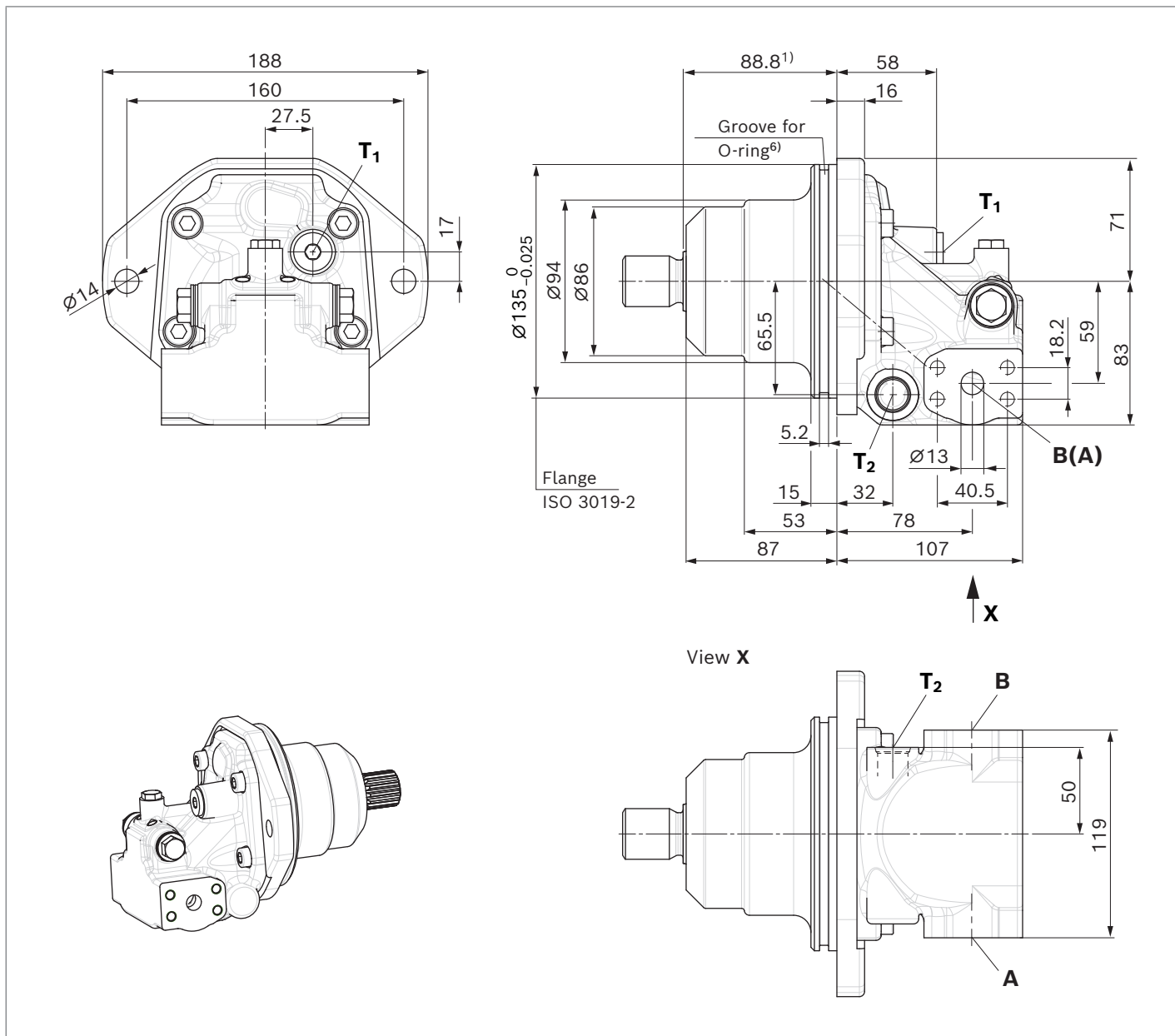

Ports		Standard	Size	p_{max} [bar] ⁽²⁾	State ⁽⁵⁾
A, B	Working port Fastening thread A/B	SAE J518 DIN 13	1/2 in M8 × 1.25; 16 deep	450	O
T₁	Drain port	DIN 3852 ⁽⁴⁾	M16 × 1.5; 12 deep	3	X ⁽³⁾
T₂	Drain port	DIN 3852 ⁽⁴⁾	M16 × 1.5; 12 deep	3	O ⁽³⁾

1) To shaft collar

2) Depending on the application, momentary pressure peaks can occur. Keep this in mind when selecting measuring devices and fittings.

3) Depending on installation position, T₁ or T₂ must be connected (see also installation instructions on page 62).

4) The countersink may be deeper than specified in the standard.

5) O = Must be connected (plugged on delivery)

X = Plugged (in normal operation)

6) O-ring Ø126 × 4 not included in the scope of delivery

Drive shafts, sizes 23 to 45

▼ Splined shaft DIN 5480, Sizes 23²⁾, 28 and 32

Z5 – W25×1.25×18×9g

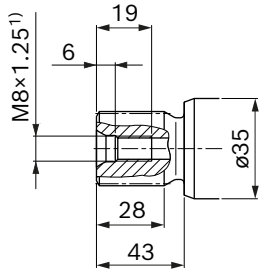

▼ Parallel keyed shaft DIN 6885, Sizes 23²⁾, 28 and 32

P5 – AS8×7×40

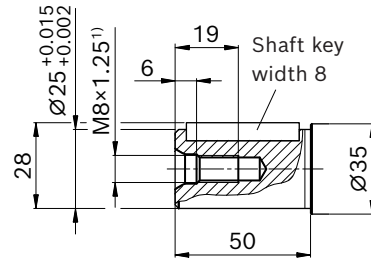

▼ Splined shaft DIN 5480, Sizes 23²⁾, 28, 32, 37 and 45³⁾

Z6 – W30×2×14×9g

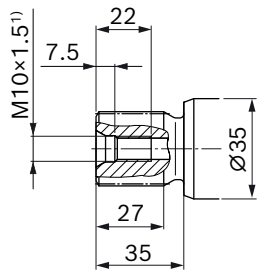

▼ Parallel keyed shaft DIN 6885, Sizes 23²⁾, 28, 32, 37 and 45³⁾

P6 – AS8×7×40

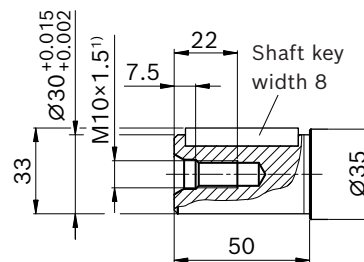

1) Center bore according to DIN 332 (thread according to DIN 13)
2) Not available for A2FMN, A2FEN (pressure range 300 to 350 bar)
3) Only available for A2FMN, A2FEN (pressure range 300 to 350 bar)

Dimensions A2FM, sizes 45 to 80

SAE working ports A and B at bottom (11)

A2FMN sizes 56, 63 and 80

A2FMM sizes 45, 56 and 63

A2FMH sizes 45, 56 and 63

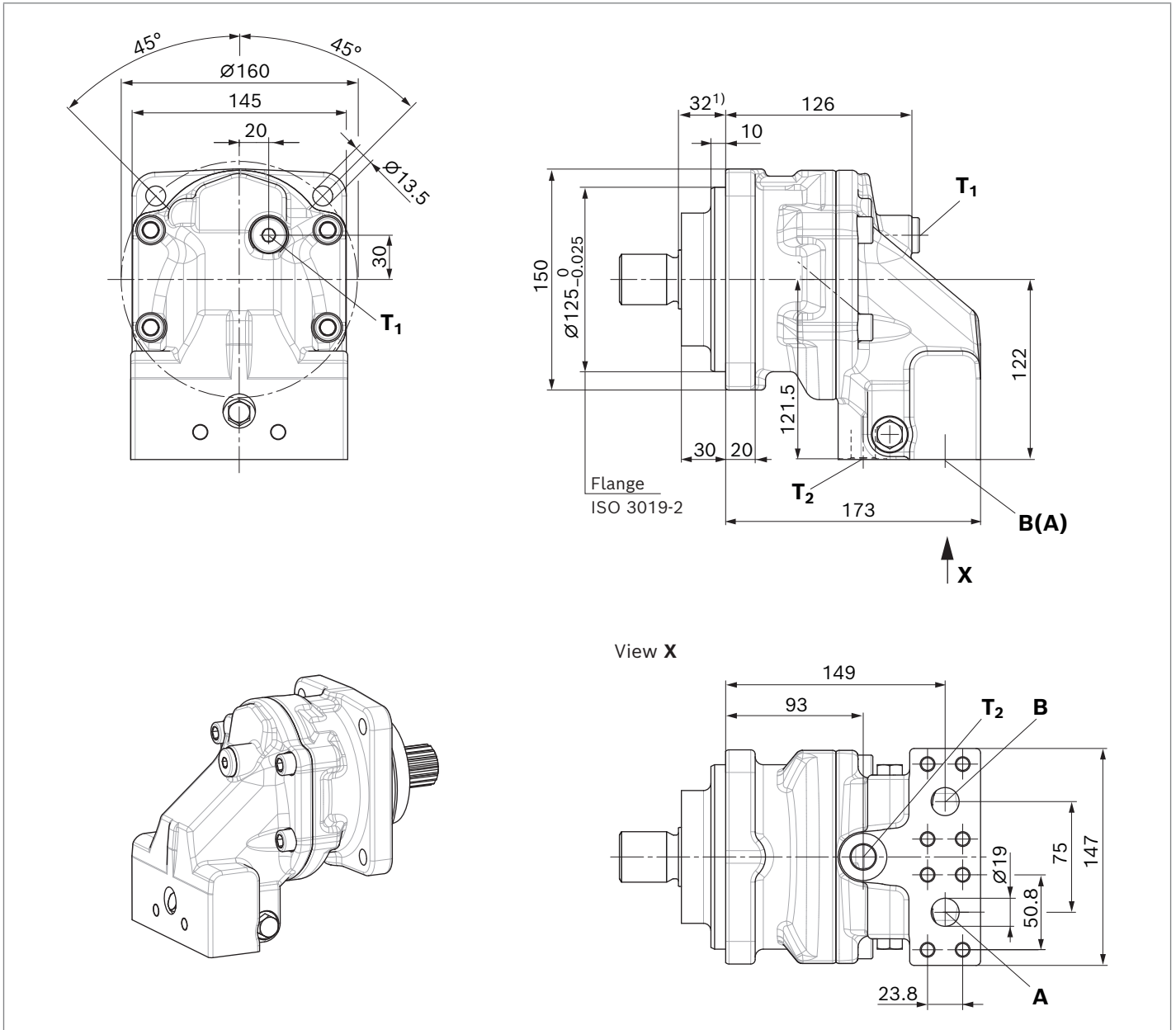

Ports	Standard	Size	p_{max} [bar] ²⁾	State ⁵⁾
A, B	Working port Fastening thread A/B	SAE J518 DIN 13	3/4 in M10 × 1.5; 17 deep	500 O
T₁	Drain port	DIN 3852 ⁴⁾	M18 × 1.5; 12 deep	3 X ³⁾
T₂	Drain port	DIN 3852 ⁴⁾	M18 × 1.5; 12 deep	3 O ³⁾

- 1) To shaft collar
- 2) Depending on the application, momentary pressure peaks can occur. Keep this in mind when selecting measuring devices and fittings.
- 3) Depending on installation position, T₁ or T₂ must be connected (see also installation instructions on page 62).
- 4) The countersink may be deeper than specified in the standard.
- 5) O = Must be connected (plugged on delivery)
 X = Plugged (in normal operation)

SAE working ports, 1× at side and 1× at bottom⁶⁾ (12)

A2FMN sizes 56, 63 and 80

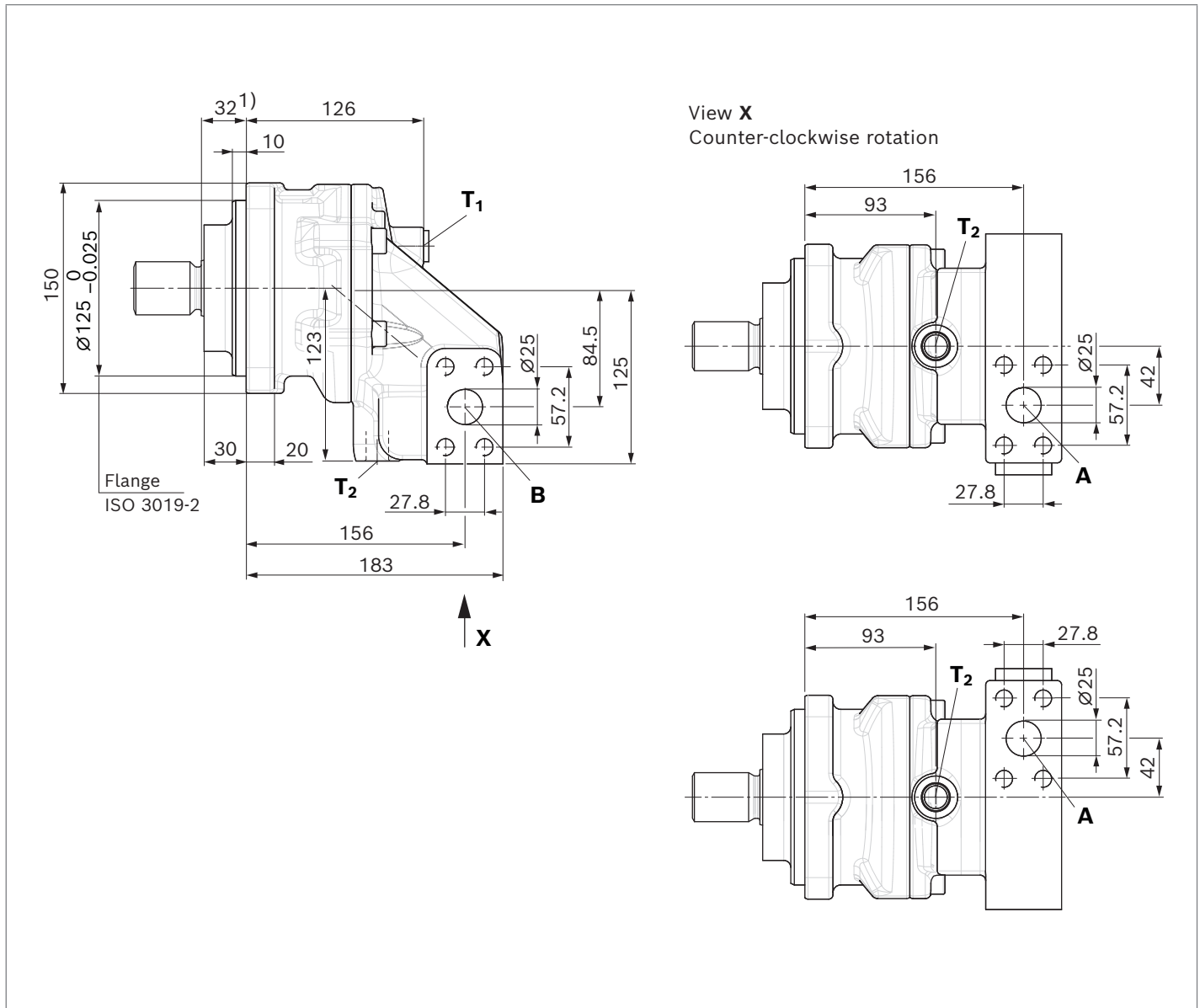

Ports		Standard	Size	p_{max} [bar] ²⁾	State ⁵⁾
A, B	Working port	SAE J518	1 in	350	O
	Fastening thread A/B	DIN 13	M12 × 1.75; 17 deep		
T₁	Drain port	DIN 3852 ⁴⁾	M18 × 1.5; 12 deep	3	X ³⁾
T₂	Drain port	DIN 3852 ⁴⁾	M18 × 1.5; 12 deep	3	O ³⁾

1) To shaft collar

2) Depending on the application, momentary pressure peaks can occur. Keep this in mind when selecting measuring devices and fittings.

3) Depending on installation position, T₁ or T₂ must be connected (see also installation instructions on page 62).

4) The countersink may be deeper than specified in the standard.

5) O = Must be connected (plugged on delivery)

X = Plugged (in normal operation)

6) Only in combination with check valve (valve design U)

SAE working ports A and B at rear (01)

A2FMN sizes 56, 63 and 80

A2FMM sizes 45, 56 and 63

A2FMH sizes 45, 56 and 63

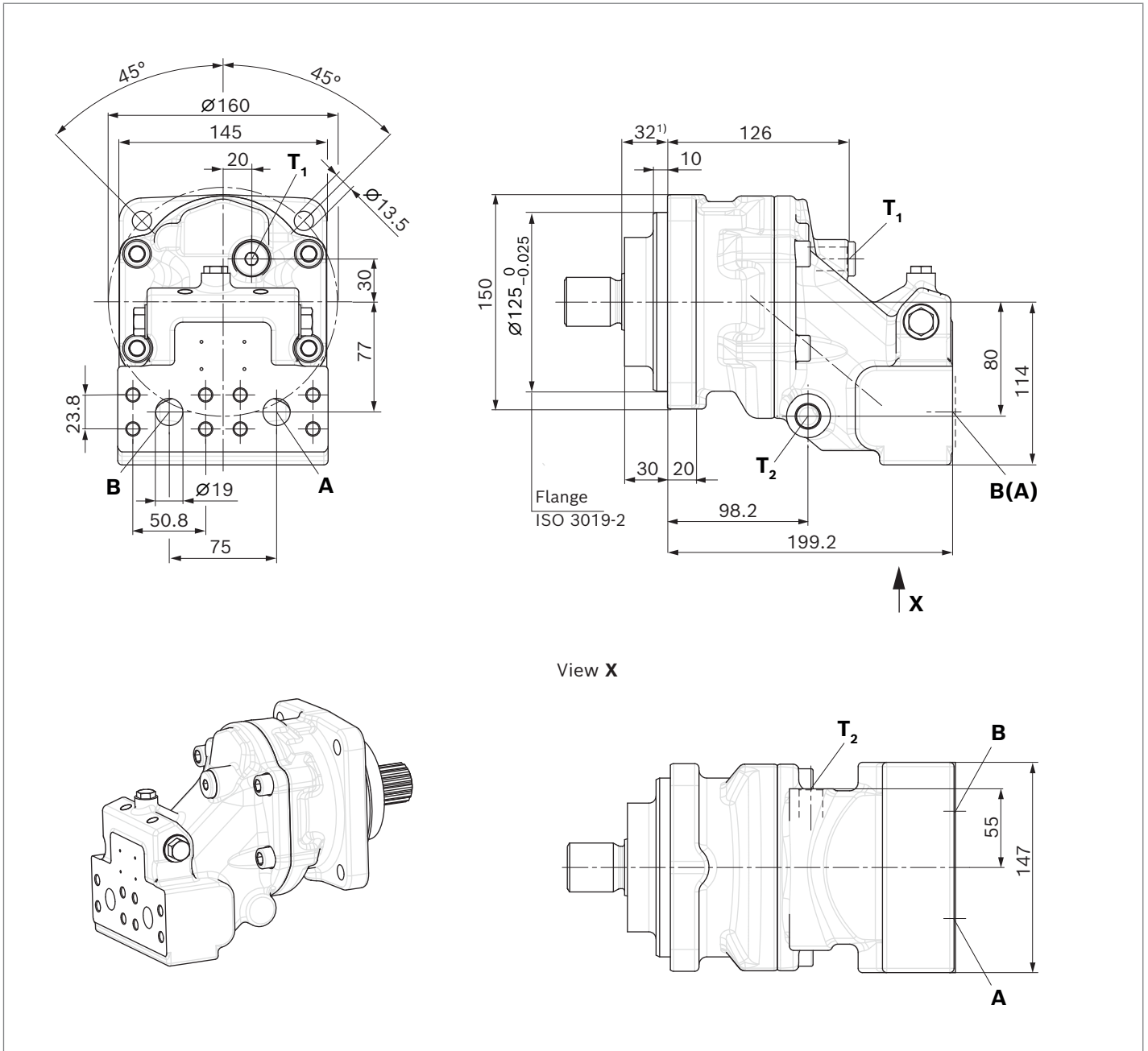

Ports		Standard	Size	p_{max} [bar] ²⁾	State ⁵⁾
A, B	Working port	SAE J518	3/4 in	500	O
	Fastening thread A/B	DIN 13	M10 × 1.5; 17 deep		
T₁	Drain port	DIN 3852 ⁴⁾	M18 × 1.5; 12 deep	3	X ³⁾
T₂	Drain port	DIN 3852 ⁴⁾	M18 × 1.5; 12 deep	3	O ³⁾

1) To shaft collar

2) Depending on the application, momentary pressure peaks can occur. Keep this in mind when selecting measuring devices and fittings.

3) Depending on installation position, T₁ or T₂ must be connected (see also installation instructions on page 62).

4) The countersink may be deeper than specified in the standard.

5) O = Must be connected (plugged on delivery)

X = Plugged (in normal operation)

SAE working ports A and B at side, opposite (02)

A2FMN sizes 56, 63 and 80

A2FMM sizes 45, 56 and 63

A2FMH sizes 45, 56 and 63

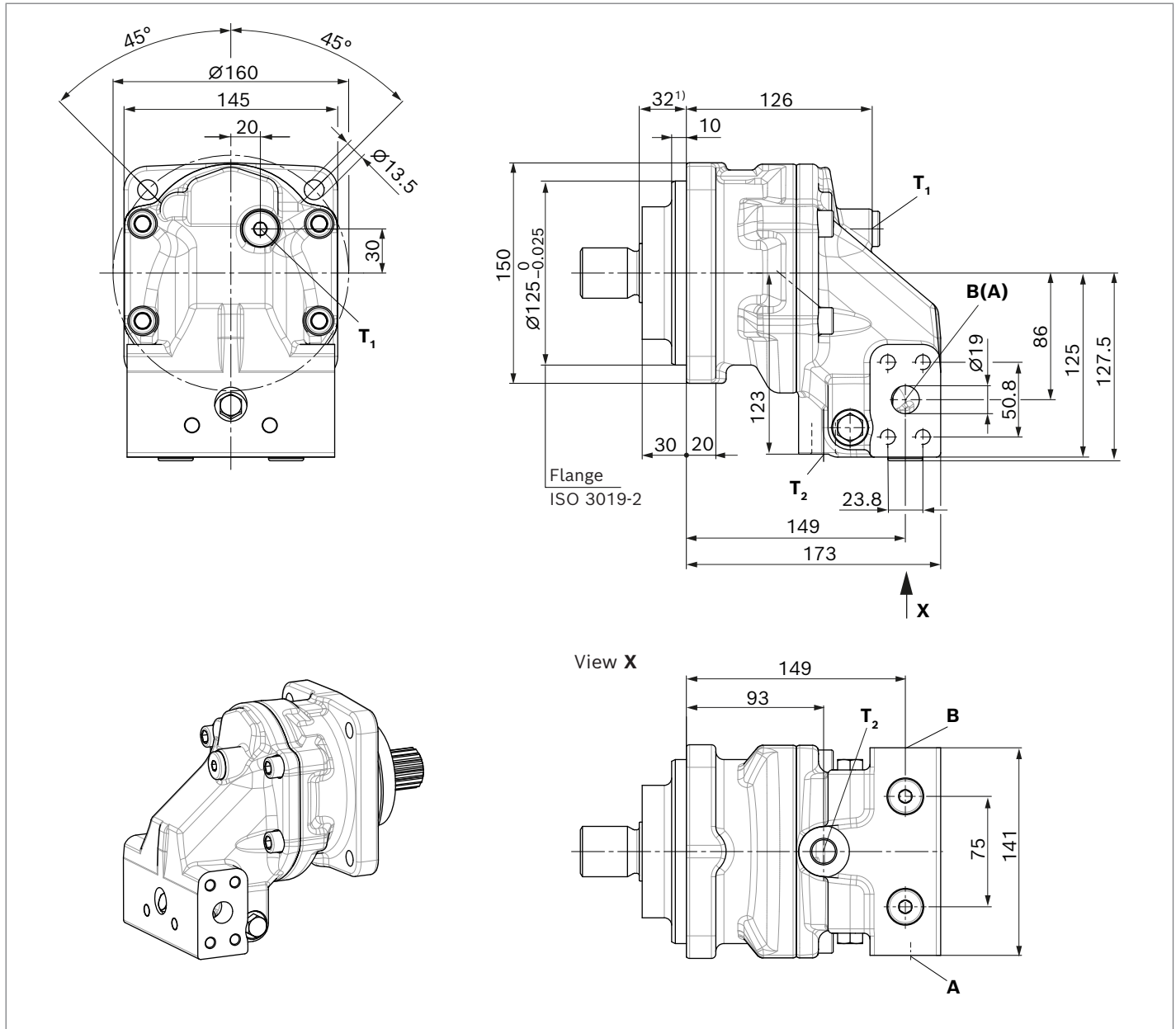

Ports		Standard	Size	p_{max} [bar] ²⁾	State ⁵⁾
A, B	Working port	SAE J518	3/4 in	500	O
	Fastening thread A/B	DIN 13	M10 × 1.5; 17 deep		
T₁	Drain port	DIN 3852 ⁴⁾	M18 × 1.5; 12 deep	3	X ³⁾
T₂	Drain port	DIN 3852 ⁴⁾	M18 × 1.5; 12 deep	3	O ³⁾

1) To shaft collar

2) Depending on the application, momentary pressure peaks can occur. Keep this in mind when selecting measuring devices and fittings.

3) Depending on installation position, T₁ or T₂ must be connected (see also installation instructions on page 62).

4) The countersink may be deeper than specified in the standard.

5) O = Must be connected (plugged on delivery)

X = Plugged (in normal operation)

Dimensions A2FE, sizes 45 to 80

SAE working ports A and B at bottom (11)

A2FEN sizes 56, 63 and 80

A2FEM sizes 45, 56 and 63

A2FEH sizes 45, 56 and 63

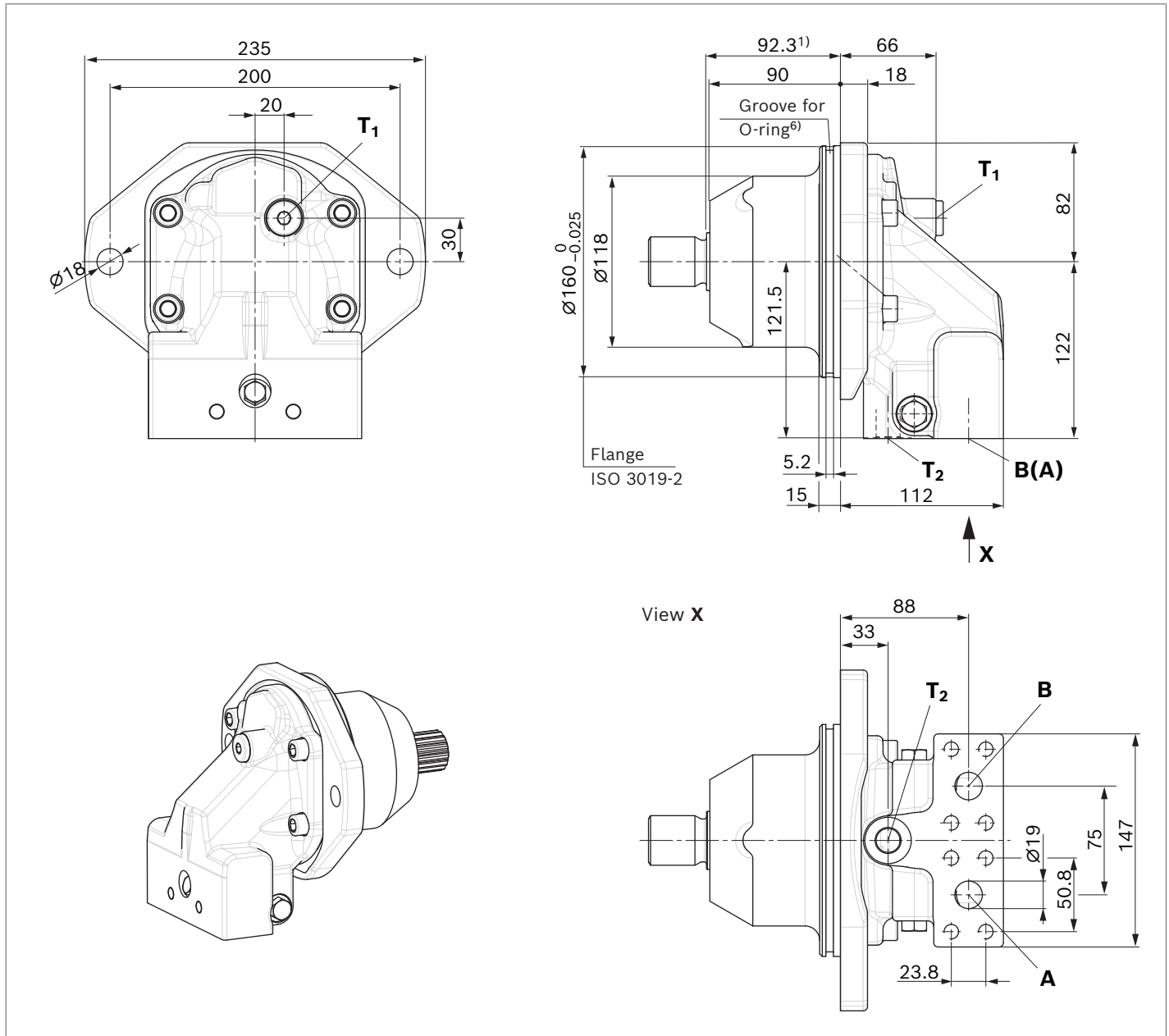

Ports		Standard	Size	p_{max} [bar] ²⁾	State ⁵⁾
A, B	Working port Fastening thread A/B	SAE J518 DIN 13	3/4 in M10 × 1.5; 17 deep	500	O
T₁	Drain port	DIN 3852 ⁴⁾	M18 × 1.5; 12 deep	3	X ³⁾
T₂	Drain port	DIN 3852 ⁴⁾	M18 × 1.5; 12 deep	3	O ³⁾

1) To shaft collar

2) Depending on the application, momentary pressure peaks can occur. Keep this in mind when selecting measuring devices and fittings.

3) Depending on installation position, T₁ or T₂ must be connected (see also installation instructions on page 62).

4) The countersink may be deeper than specified in the standard.

5) O = Must be connected (plugged on delivery)

X = Plugged (in normal operation)

6) O-ring $\varnothing 150 \times 4$ not included in the scope of delivery.

SAE working ports A and B at rear (01)

A2FEN sizes 56, 63 and 80

A2FEM sizes 45, 56 and 63

A2FEH sizes 45, 56 and 63

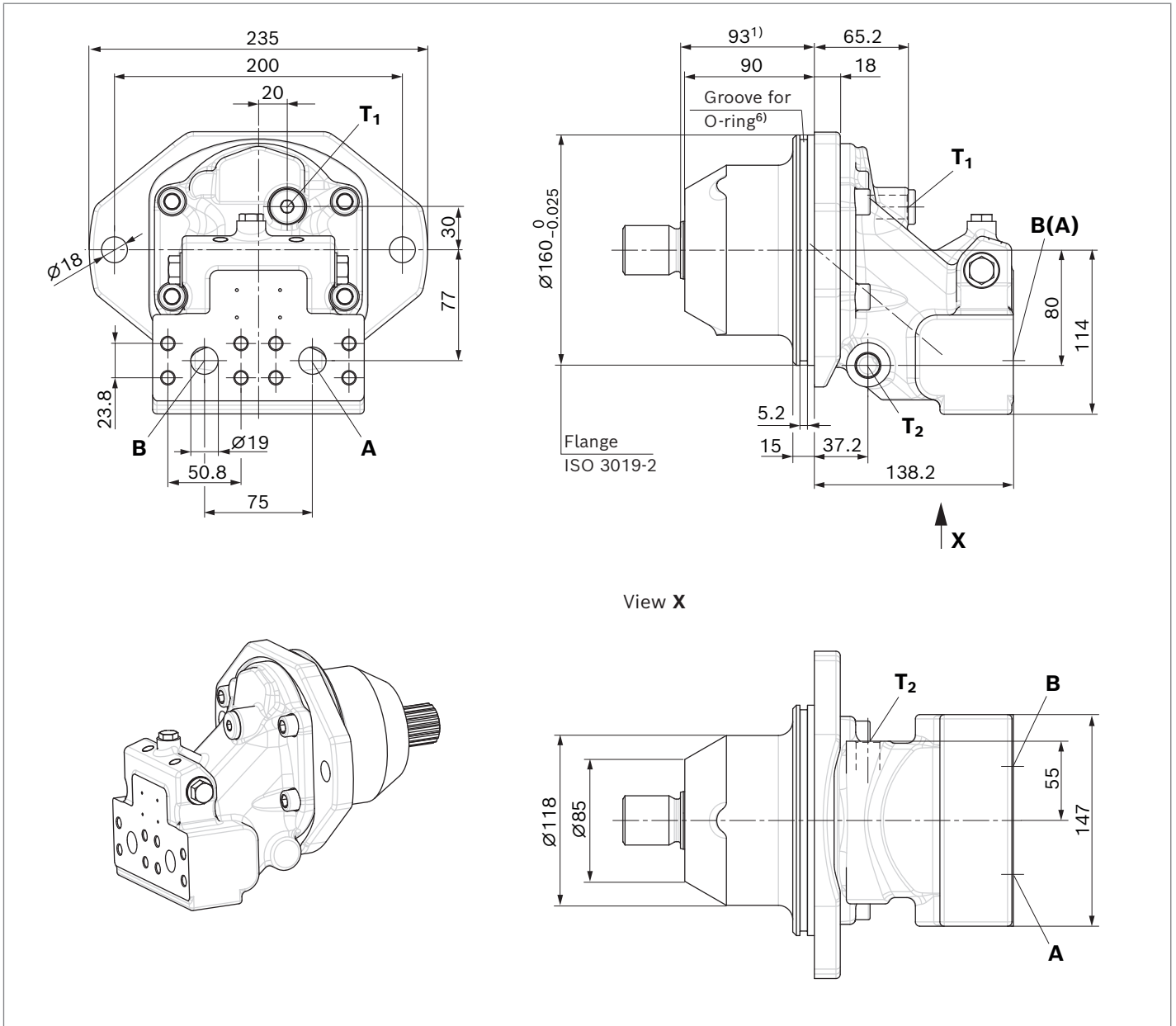

Ports		Standard	Size	p_{max} [bar] ²⁾	State ⁵⁾
A, B	Working port	SAE J518	3/4 in	500	O
	Fastening thread A/B	DIN 13	M10 × 1.5; 17 deep		
T₁	Drain port	DIN 3852 ⁴⁾	M18 × 1.5; 12 deep	3	X ³⁾
T₂	Drain port	DIN 3852 ⁴⁾	M18 × 1.5; 12 deep	3	O ³⁾

1) To shaft collar

2) Depending on the application, momentary pressure peaks can occur. Keep this in mind when selecting measuring devices and fittings.

3) Depending on installation position, T₁ or T₂ must be connected (see also installation instructions on page 62).

4) The countersink may be deeper than specified in the standard.

5) O = Must be connected (plugged on delivery)

X = Plugged (in normal operation)

6) O-ring Ø150 × 4 not included in the scope of delivery.

SAE working ports at side, opposite (02)

A2FEN sizes 56, 63 and 80

A2FEM sizes 45, 56 and 63

A2FEH sizes 45, 56 and 63

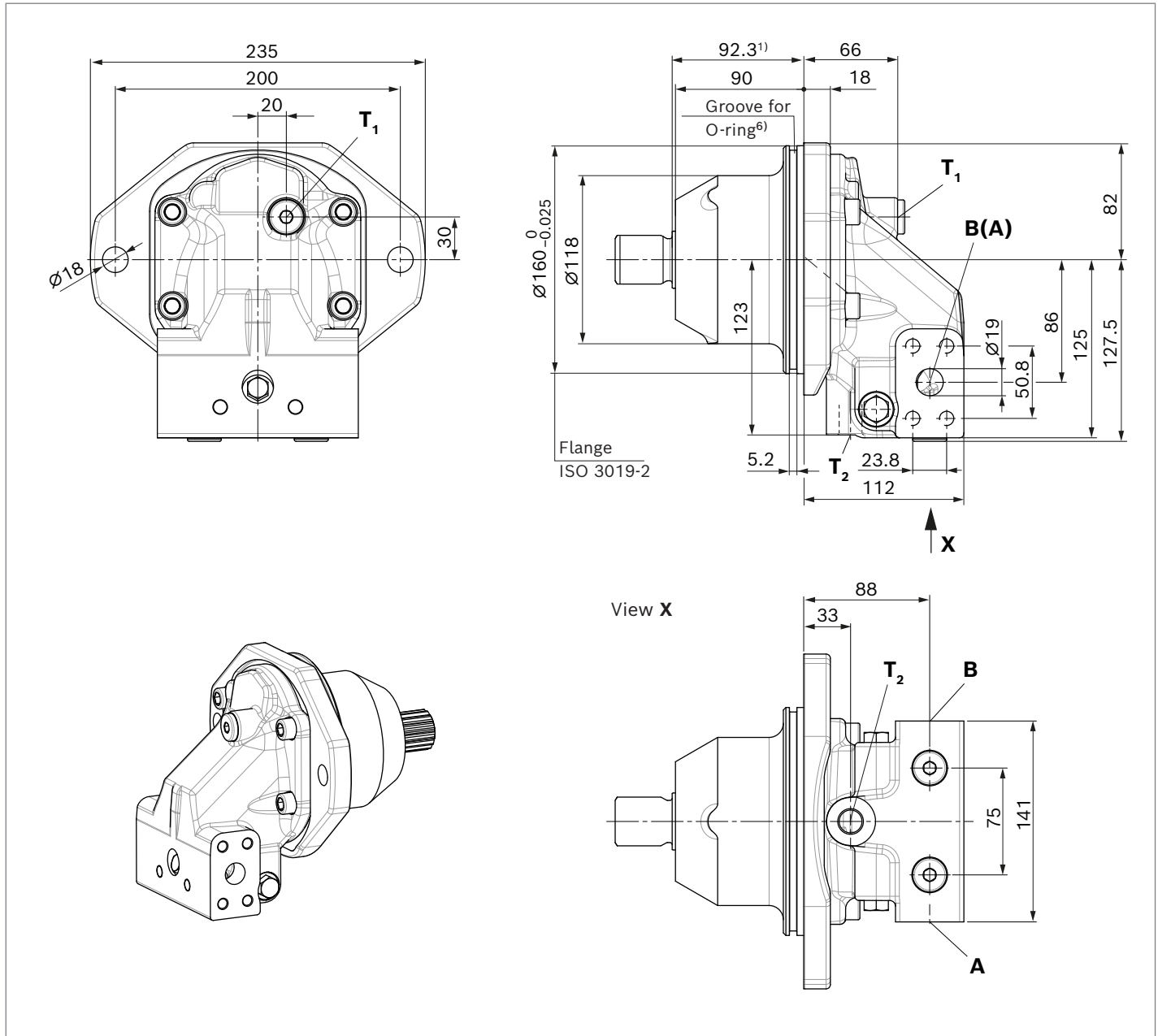

Ports		Standard	Size	p_{max} [bar] ³²⁾	State ⁵⁾
A, B	Working port Fastening thread A/B	SAE J518 DIN 13	3/4 in M10 × 1.5; 17 deep	500	O
T₁	Drain port	DIN 3852 ⁴⁾	M18 × 1.5; 12 deep	3	X ³⁾
T₂	Drain port	DIN 3852 ⁴⁾	M18 × 1.5; 12 deep	3	O ³⁾

1) To shaft collar
 2) Depending on the application, momentary pressure peaks can occur. Keep this in mind when selecting measuring devices and fittings.
 3) Depending on installation position, T₁ or T₂ must be connected (see also installation instructions on page 62).

4) The countersink may be deeper than specified in the standard.
 5) O = Must be connected (plugged on delivery)
 X = Plugged (in normal operation)
 6) O-ring Ø150 × 4 not included in the scope of delivery.

Threaded ports A and B at side and at rear (03)

A2FEN size 45

A2FEM sizes 56 and 63

A2FEH sizes 56 and 63

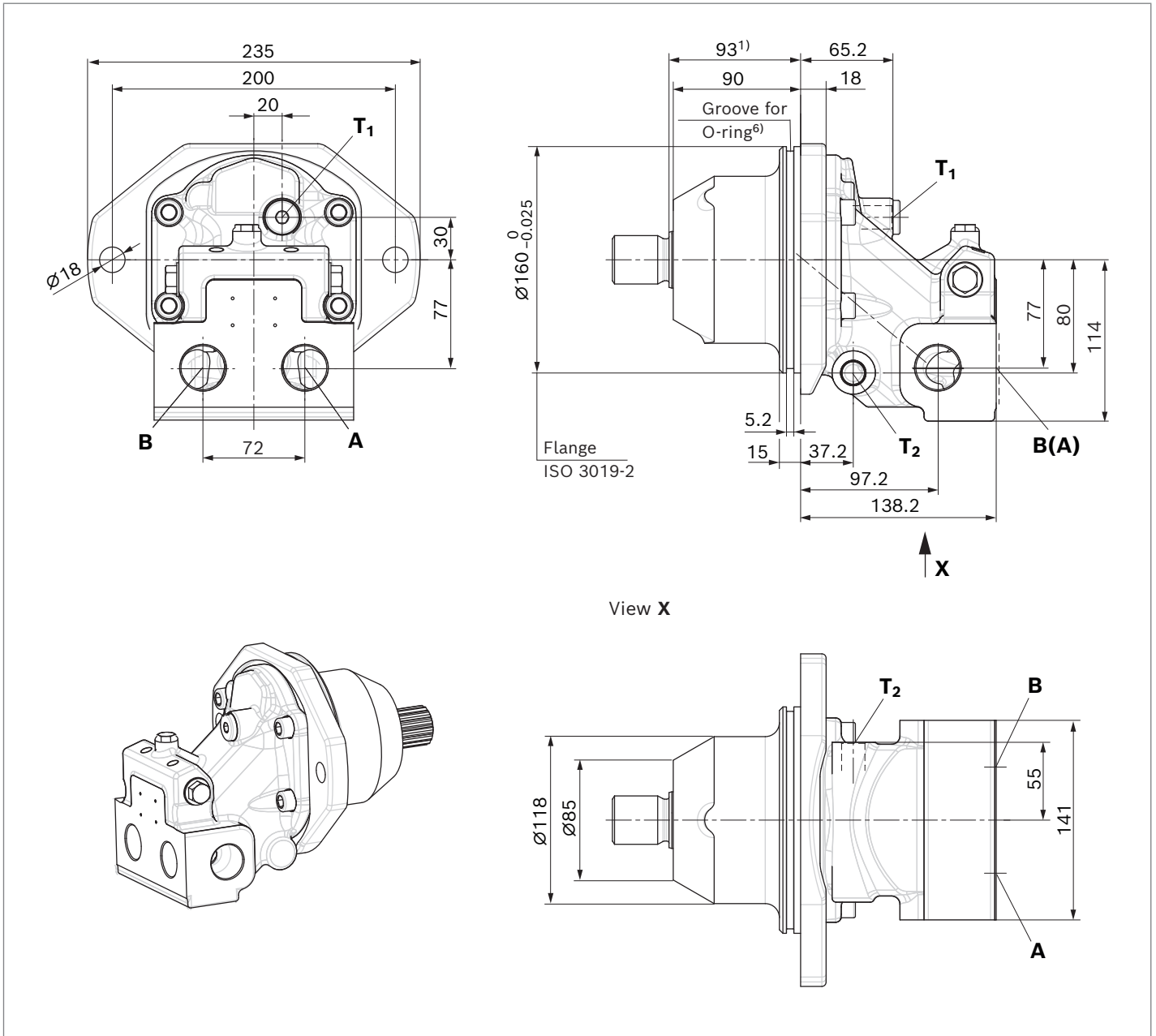

Ports		Standard	Size	p_{max} [bar] ²⁾	State ⁵⁾
A, B	Working port	DIN 3852	M33 × 2; 18 deep	500	O (1 × each)
T ₁	Drain port	DIN 3852 ⁴⁾	M18 × 1.5; 12 deep	3	X ³⁾
T ₂	Drain port	DIN 3852 ⁴⁾	M18 × 1.5; 12 deep	3	O ³⁾

1) To shaft collar
 2) Depending on the application, momentary pressure peaks can occur. Keep this in mind when selecting measuring devices and fittings.
 3) Depending on installation position, T₁ or T₂ must be connected (see also installation instructions on page 62).

4) The countersink may be deeper than specified in the standard.
 5) O = Must be connected (plugged on delivery)
 X = Plugged (in normal operation)
 6) O-ring $\varnothing 150 \times 4$ not included in the scope of delivery.

Drive shafts, sizes 45 to 80

▼ Splined shaft DIN 5480, Sizes 45³⁾ and 56²⁾

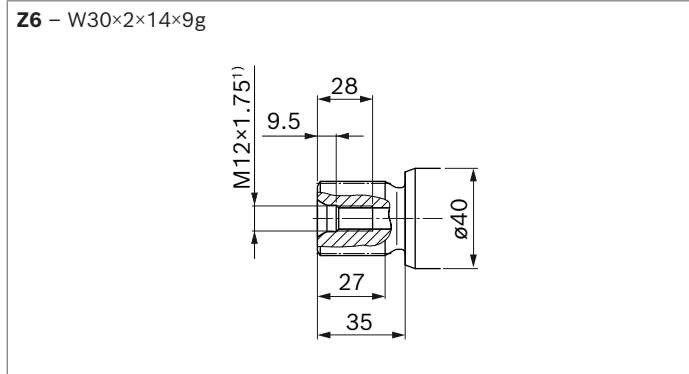

▼ Parallel keyed shaft DIN 6885, Sizes 45³⁾ and 56²⁾

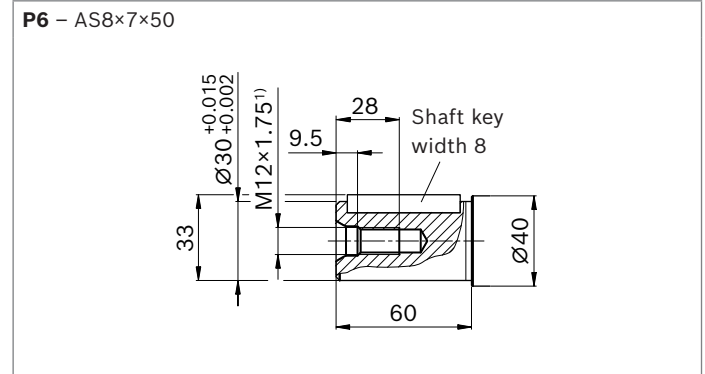

▼ Splined shaft DIN 5480, Sizes 56³⁾, 63 and 80⁴⁾

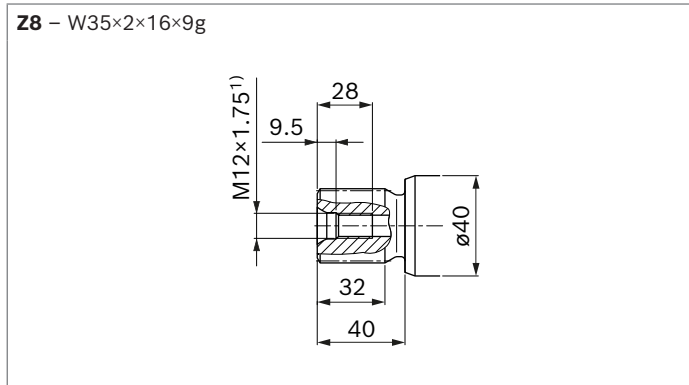

▼ Parallel keyed shaft DIN 6885, Sizes 56³⁾, 63 and 80⁴⁾

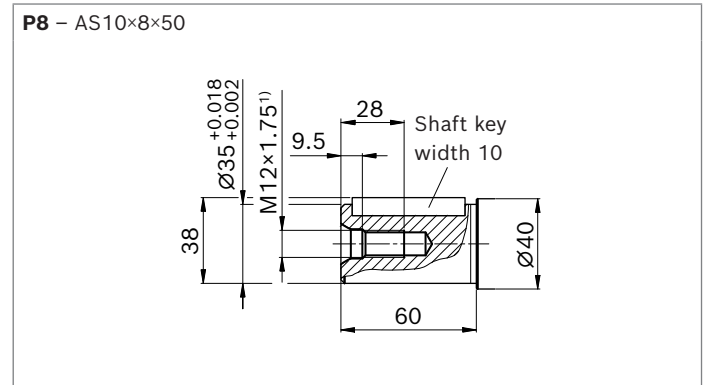

1) Center bore according to DIN 332 (thread according to DIN 13)
2) Not available for A2FMH, A2FEH (pressure range 450 to 500 bar)
3) Not available for A2FMN, A2FEN (pressure range 300 to 350 bar)
4) Only available for A2FMN, A2FEN (pressure range 300 to 350 bar)

Dimensions A2FM, sizes 80 to 107

SAE working ports at bottom (11)

A2FMN sizes 90 and 107

A2FMM sizes 80 and 90

A2FMH sizes 80 and 90

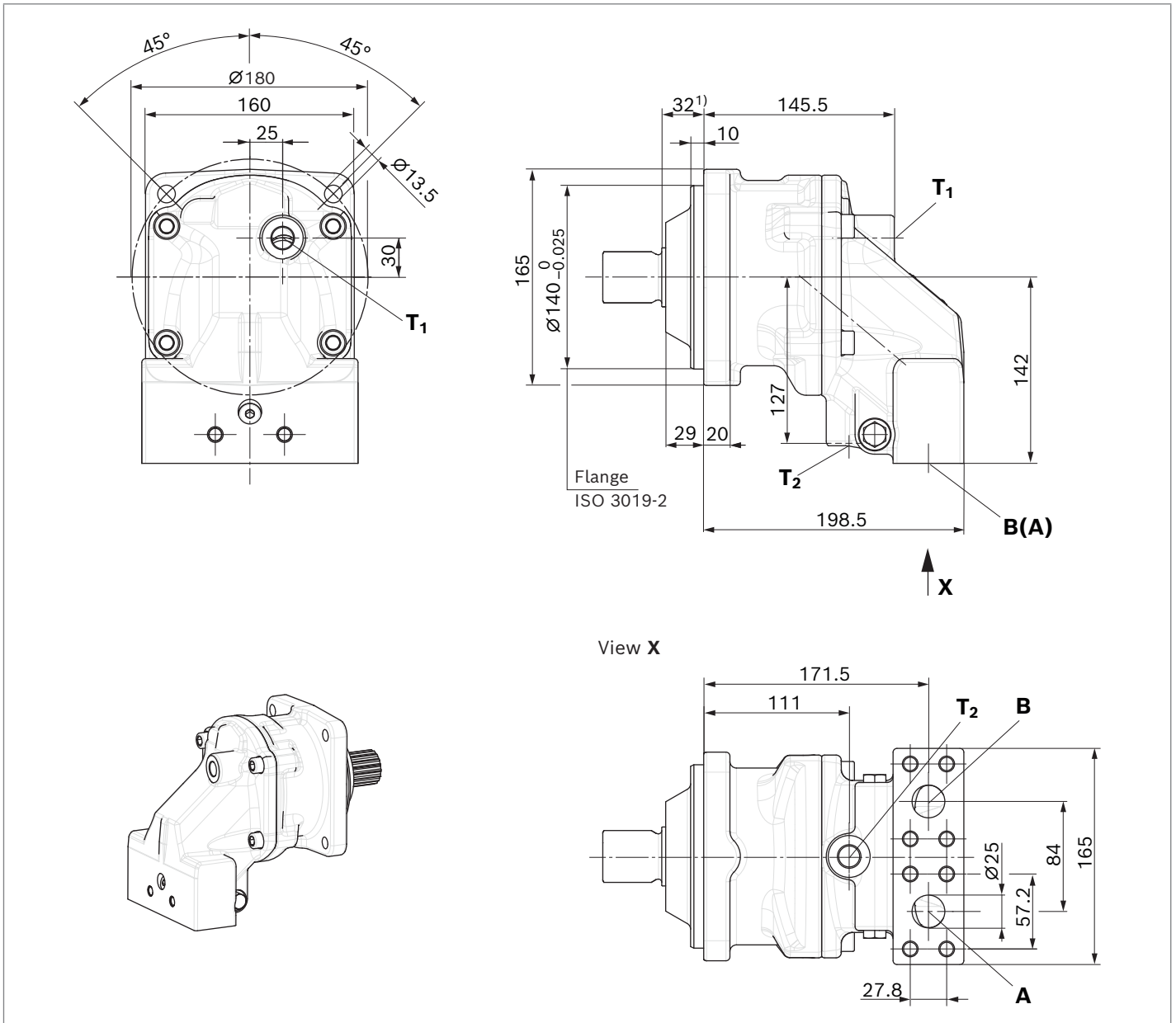

Ports		Standard	Size	p_{max} [bar] ²⁾	State ⁵⁾
A, B	Working port Fastening thread A/B	SAE J518 DIN 13	1 in M12 × 1.75; 17 deep	500	O
T₁	Drain port	DIN 3852 ⁴⁾	M18 × 1.5; 12 deep	3	X ³⁾
T₂	Drain port	DIN 3852 ⁴⁾	M18 × 1.5; 12 deep	3	O ³⁾

1) To shaft collar

2) Depending on the application, momentary pressure peaks can occur. Keep this in mind when selecting measuring devices and fittings.

3) Depending on installation position, T₁ or T₂ must be connected (see also installation instructions on page 62).

4) The countersink may be deeper than specified in the standard.

5) O = Must be connected (plugged on delivery)

X = Plugged (in normal operation)

SAE working ports A and B at rear (01)

A2FMN sizes 90 and 107

A2FMM sizes 80 and 90

A2FMH sizes 80 and 90

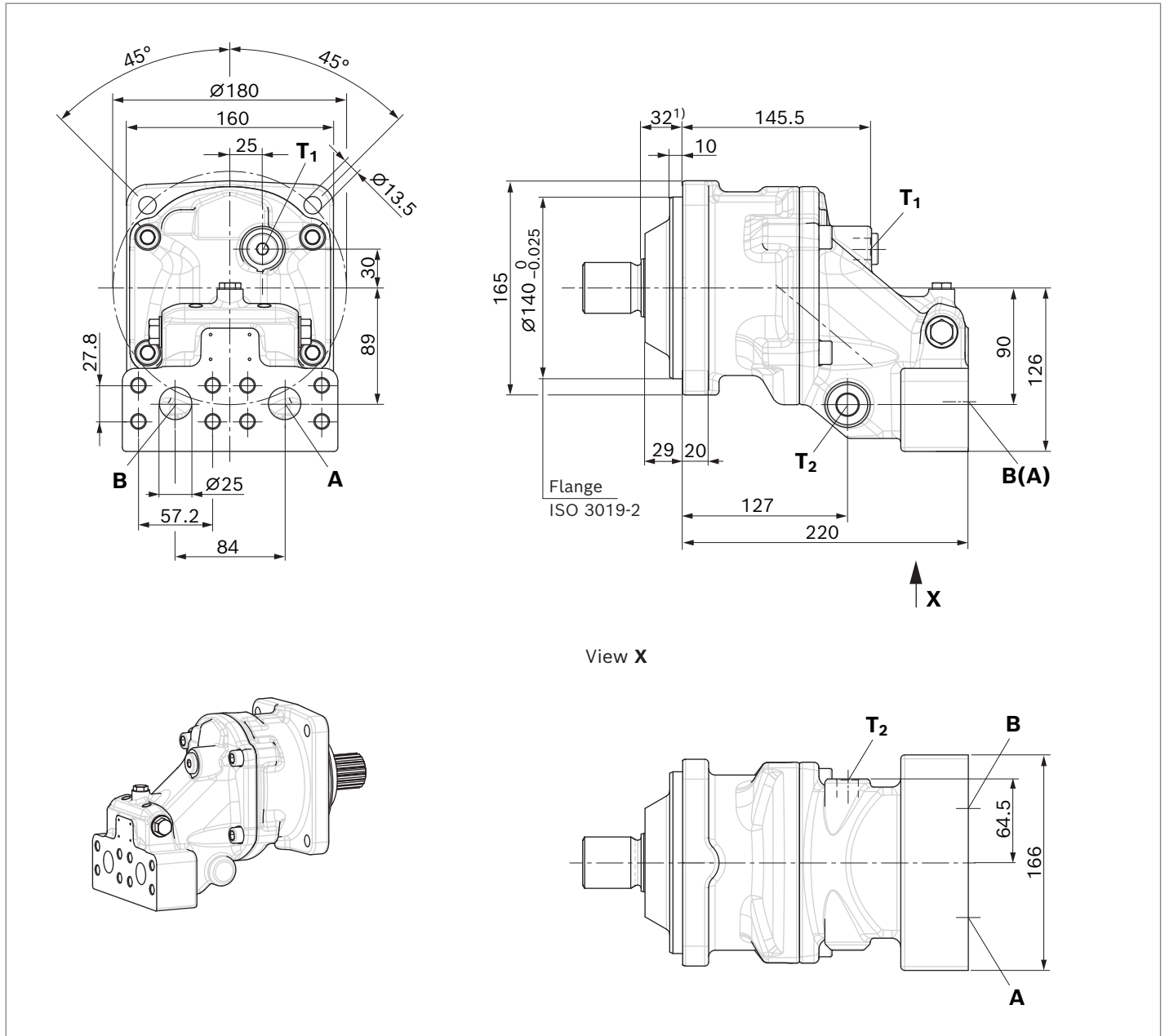

Ports		Standard	Size	p_{max} [bar] ²⁾	State ⁵⁾
A, B	Working port	SAE J518	1 in	500	O
	Fastening thread A/B	DIN 13	M12 × 1.75; 17 deep		
T₁	Drain port	DIN 3852 ⁴⁾	M18 × 1.5; 12 deep	3	X ³⁾
T₂	Drain port	DIN 3852 ⁴⁾	M18 × 1.5; 12 deep	3	O ³⁾

1) To shaft collar

2) Depending on the application, momentary pressure peaks can occur. Keep this in mind when selecting measuring devices and fittings.

3) Depending on installation position, T₁ or T₂ must be connected (see also installation instructions on page 62).

4) The countersink may be deeper than specified in the standard.

5) O = Must be connected (plugged on delivery)

X = Plugged (in normal operation)

SAE working ports at side, opposite (02)

A2FMN sizes 90 and 107

A2FMM sizes 80 and 90

A2FMH sizes 80 and 90

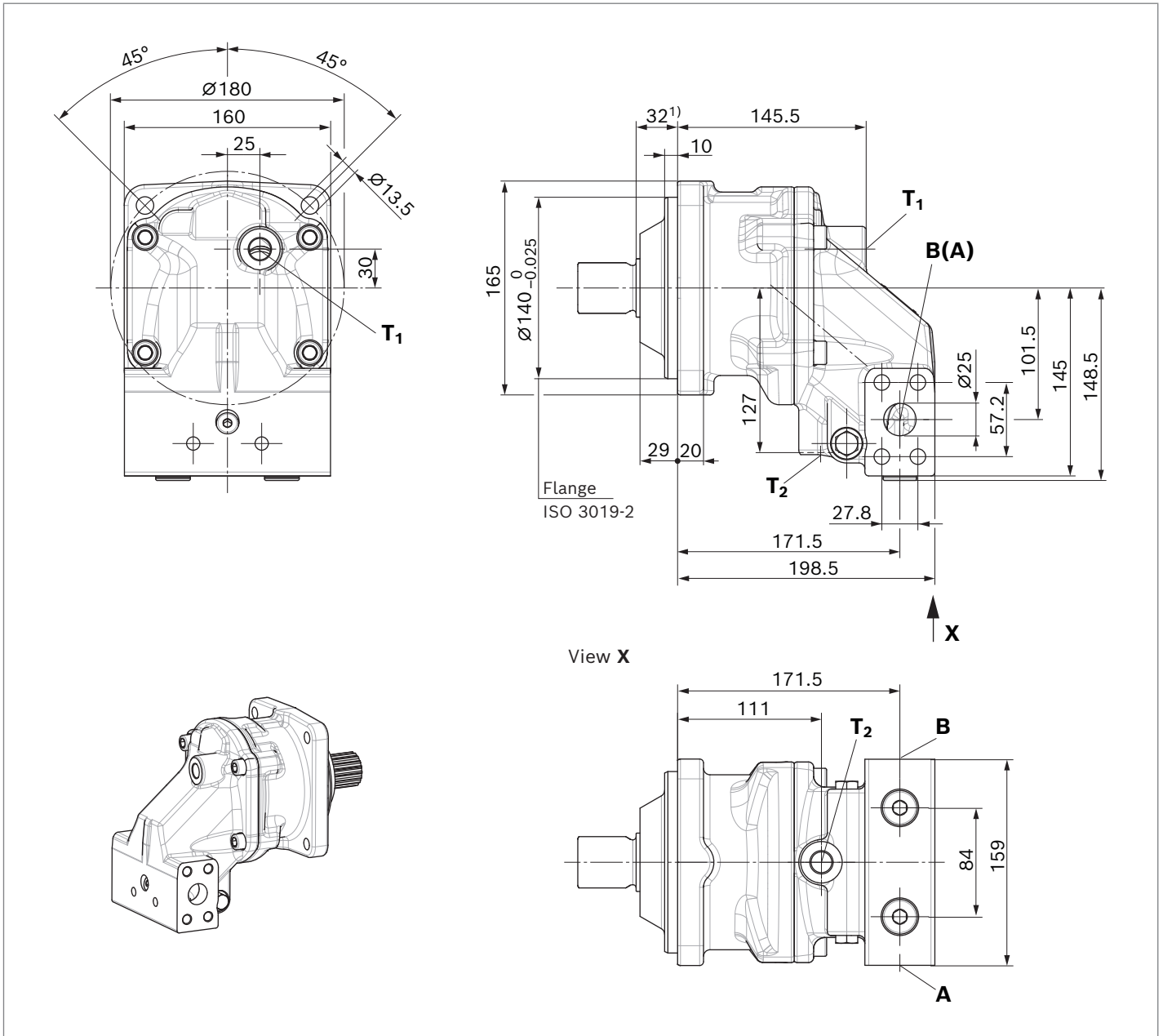

Ports	Standard	Size	p_{max} [bar] ²⁾	State ⁵⁾
A, B	SAE J518	1 in	500	O
	DIN 13	M12 × 1.75; 17 deep		
T₁	DIN 3852 ⁴⁾	M18 × 1.5; 12 deep	3	X ³⁾
T₂	DIN 3852 ⁴⁾	M18 × 1.5; 12 deep	3	O ³⁾

1) To shaft collar

2) Depending on the application, momentary pressure peaks can occur. Keep this in mind when selecting measuring devices and fittings.

3) Depending on installation position, T_1 or T_2 must be connected (see also installation instructions on page 62).

4) The countersink may be deeper than specified in the standard.

5) O = Must be connected (plugged on delivery)

X = Plugged (in normal operation)

Dimensions A2FE, sizes 80 to 107

SAE working ports at bottom (11)

A2FEN sizes 90 and 107

A2FEM sizes 80 and 90

A2FEH sizes 80 and 90

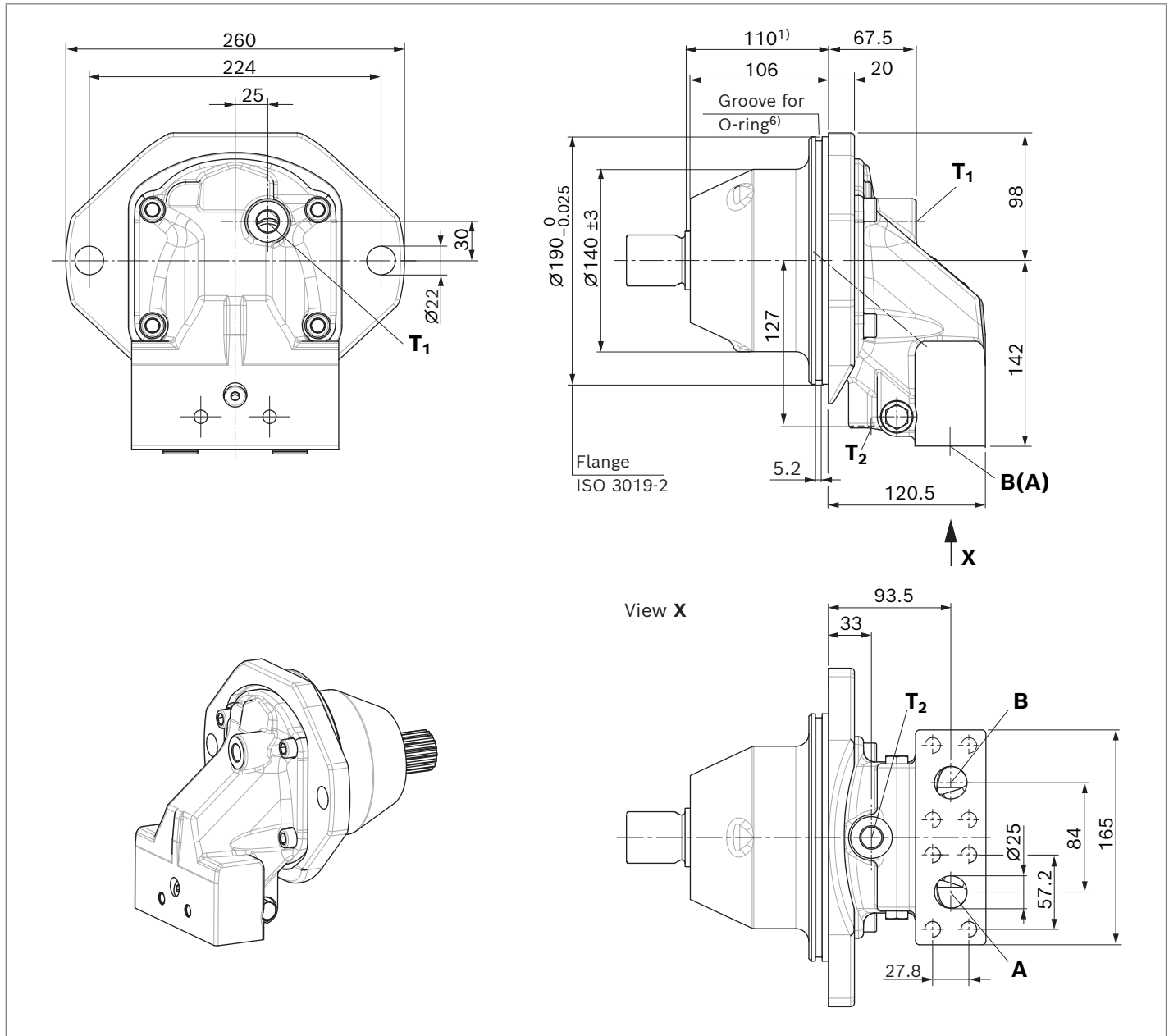

Ports		Standard	Size	p_{max} [bar] ²⁾	State ⁵⁾
A, B	Working port Fastening thread A/B	SAE J518 DIN 13	1 in M12 × 1.75; 17 deep	500	O
T₁	Drain port	DIN 3852 ⁴⁾	M18 × 1.5; 12 deep	3	X ³⁾
T₂	Drain port	DIN 3852 ⁴⁾	M18 × 1.5; 12 deep	3	O ³⁾

1) To shaft collar

2) Depending on the application, momentary pressure peaks can occur. Keep this in mind when selecting measuring devices and fittings.

3) Depending on installation position, T₁ or T₂ must be connected (see also installation instructions on page 62).

4) The countersink may be deeper than specified in the standard.

5) O = Must be connected (plugged on delivery)
X = Plugged (in normal operation)

6) O-ring $\varnothing 180 \times 4$ not included in the scope of delivery.

SAE working ports A and B at rear (01)

A2FEN sizes 90 and 107

A2FEM sizes 80 and 90

A2FEH sizes 80 and 90

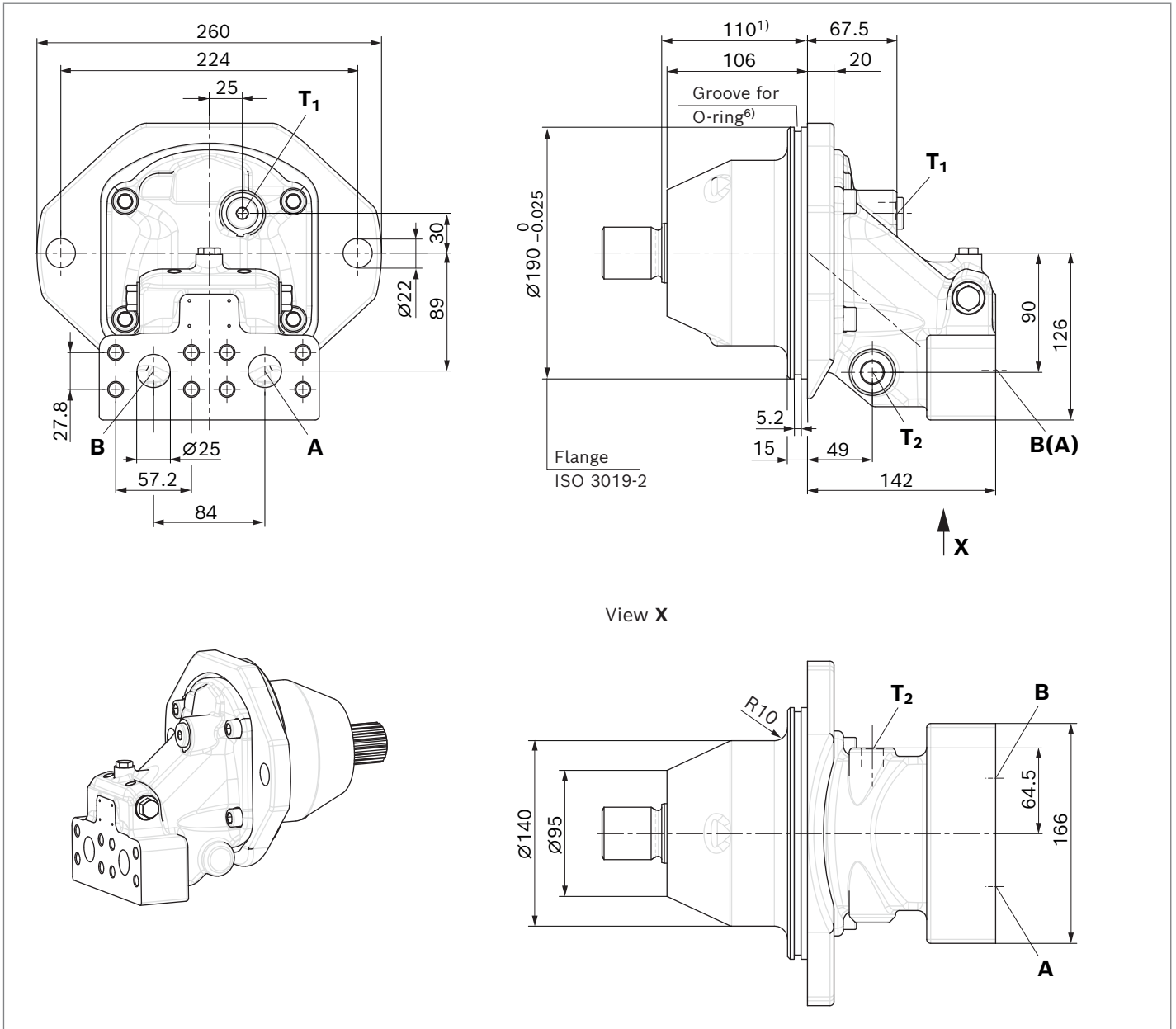

Ports		Standard	Size	p_{max} [bar] ²⁾	State ⁵⁾
A, B	Working port	SAE J518	1 in	500	O
	Fastening thread A/B	DIN 13	M12 × 1.75; 17 deep		
T₁	Drain port	DIN 3852 ⁴⁾	M18 × 1.5; 12 deep	3	X ³⁾
T₂	Drain port	DIN 3852 ⁴⁾	M18 × 1.5; 12 deep	3	O ³⁾

1) To shaft collar

2) Depending on the application, momentary pressure peaks can occur. Keep this in mind when selecting measuring devices and fittings.

3) Depending on installation position, T₁ or T₂ must be connected (see also installation instructions on page 62).

4) The countersink may be deeper than specified in the standard.

5) O = Must be connected (plugged on delivery)

X = Plugged (in normal operation)

6) O-ring Ø180 × 4 not included in the scope of delivery.

SAE working ports at side, opposite (02)

A2FEN sizes 90 and 107

A2FEM sizes 80 and 90

A2FEH sizes 80 and 90

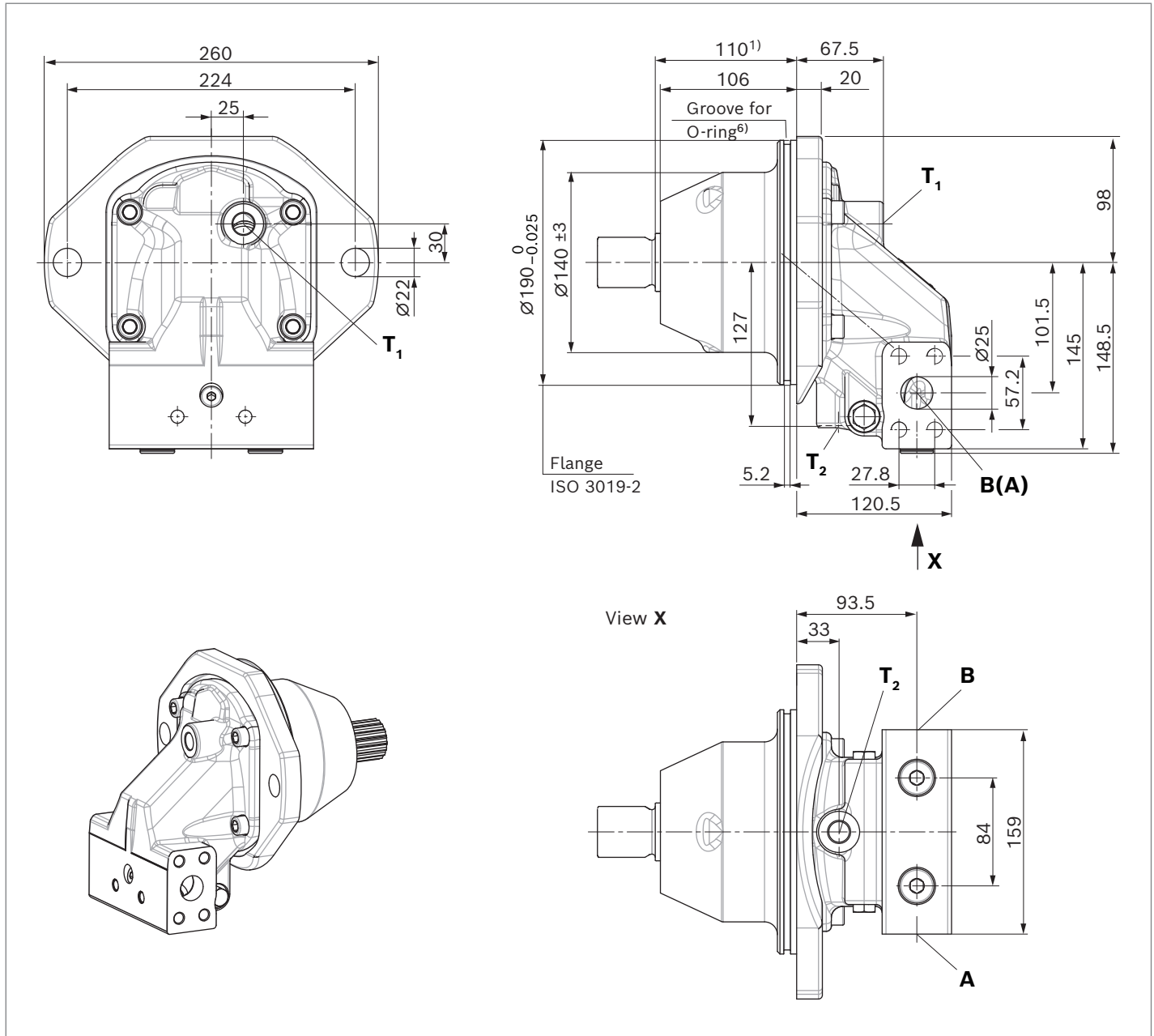

Ports		Standard	Size	p_{max} [bar] ²⁾	State ⁵⁾
A, B	Working port	SAE J518	1 in	500	O
	Fastening thread A/B	DIN 13	M12 × 1.75; 17 deep		
T₁	Drain port	DIN 3852 ⁴⁾	M18 × 1.5; 12 deep	3	X ³⁾
T₂	Drain port	DIN 3852 ⁴⁾	M18 × 1.5; 12 deep	3	O ³⁾

1) To shaft collar

2) Depending on the application, momentary pressure peaks can occur. Keep this in mind when selecting measuring devices and fittings.

3) Depending on installation position, T₁ or T₂ must be connected (see also installation instructions on page 62).

4) The countersink may be deeper than specified in the standard.

5) O = Must be connected (plugged on delivery)

X = Plugged (in normal operation)

6) O-ring Ø180 × 4 not included in the scope of delivery.

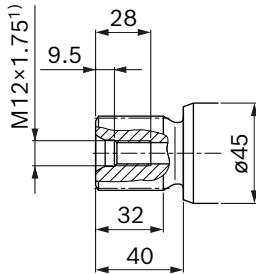
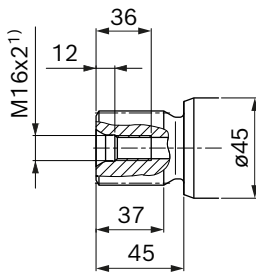
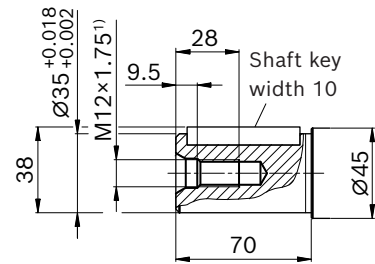
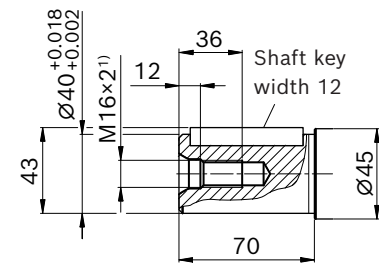
Drive shafts, sizes 80 to 107▼ **Splined shaft DIN 5480,**
Sizes 80²⁾³⁾**Z8** – W35×2×16×9g▼ **Splined shaft DIN 5480,**
Sizes 80³⁾, 90 and 107⁴⁾**Z9** – W40×2×18×9g▼ **Parallel keyed shaft DIN 6885,**
Sizes 80²⁾³⁾**P8** – AS10×8×56▼ **Parallel keyed shaft DIN 6885,**
Sizes 80³⁾, 90 and 107⁴⁾**P9** – AS12×8×56

- 1) Center bore according to DIN 332 (thread according to DIN 13)
- 2) Not available for A2FMH, A2FEH (pressure range 450 to 500 bar)
- 3) Not available for A2FMN, A2FEN (pressure range 300 to 350 bar)
- 4) Only available for A2FMN, A2FEN (pressure range 300 to 350 bar)

Dimensions A2FM, sizes 107 and 125

SAE working ports at bottom (11)

A2FMM sizes 107 and 125

A2FMH sizes 107 and 125

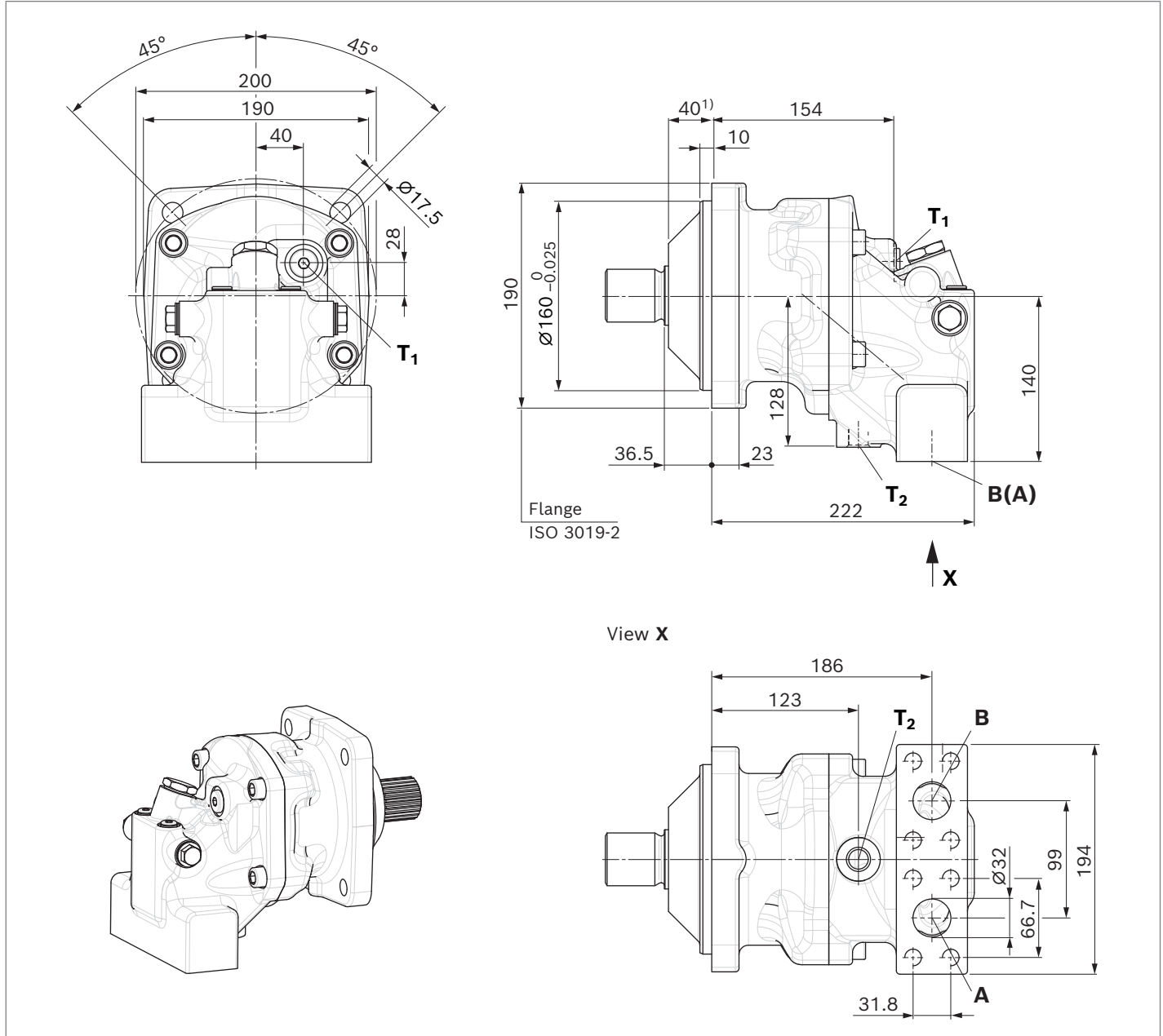

Ports		Standard	Size	p_{max} [bar] ⁽²⁾	State ⁽⁵⁾
A, B	Working port Fastening thread A/B	SAE J518 DIN 13	1 1/4 in M14 × 2; 23 deep	500	O
T₁	Drain port	DIN 3852 ⁽⁴⁾	M18 × 1.5; 12 deep	3	X ⁽³⁾
T₂	Drain port	DIN 3852 ⁽⁴⁾	M18 × 1.5; 12 deep	3	O ⁽³⁾

- 1) To shaft collar
- 2) Depending on the application, momentary pressure peaks can occur. Keep this in mind when selecting measuring devices and fittings.
- 3) Depending on installation position, T₁ or T₂ must be connected (see also installation instructions on page 62).

- 4) The countersink may be deeper than specified in the standard.
- 5) O = Must be connected (plugged on delivery)
 X = Plugged (in normal operation)

SAE working ports at rear (01)

A2FMM sizes 107 and 125

A2FMH sizes 107 and 125

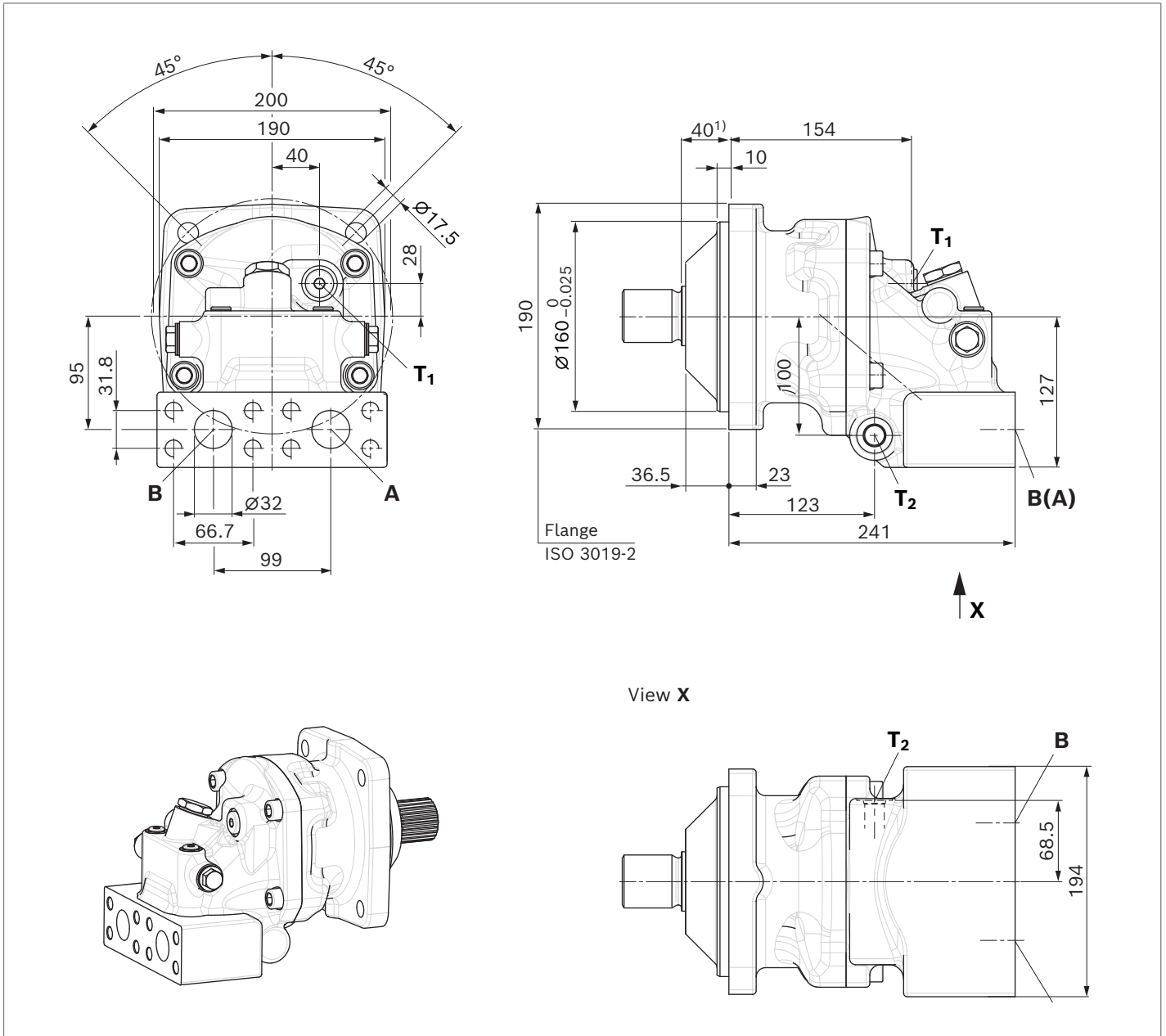

Ports	Standard	Size	p_{max} [bar] ²⁾	State ⁵⁾
A, B	Working port Fastening thread A/B	SAE J518 DIN 13	1 1/4 in M14 × 2; 23 deep	500 O
T₁	Drain port	DIN 3852 ⁴⁾	M18 × 1.5; 12 deep	3 X ³⁾
T₂	Drain port	DIN 3852 ⁴⁾	M18 × 1.5; 12 deep	3 O ³⁾

1) To shaft collar
 2) Depending on the application, momentary pressure peaks can occur. Keep this in mind when selecting measuring devices and fittings.
 3) Depending on installation position, T₁ or T₂ must be connected (see also installation instructions on page 62).

4) The countersink may be deeper than specified in the standard.
 5) O = Must be connected (plugged on delivery)
 X = Plugged (in normal operation)

SAE working ports at side, opposite (02)

A2FMM sizes 107 and 125

A2FMH sizes 107 and 125

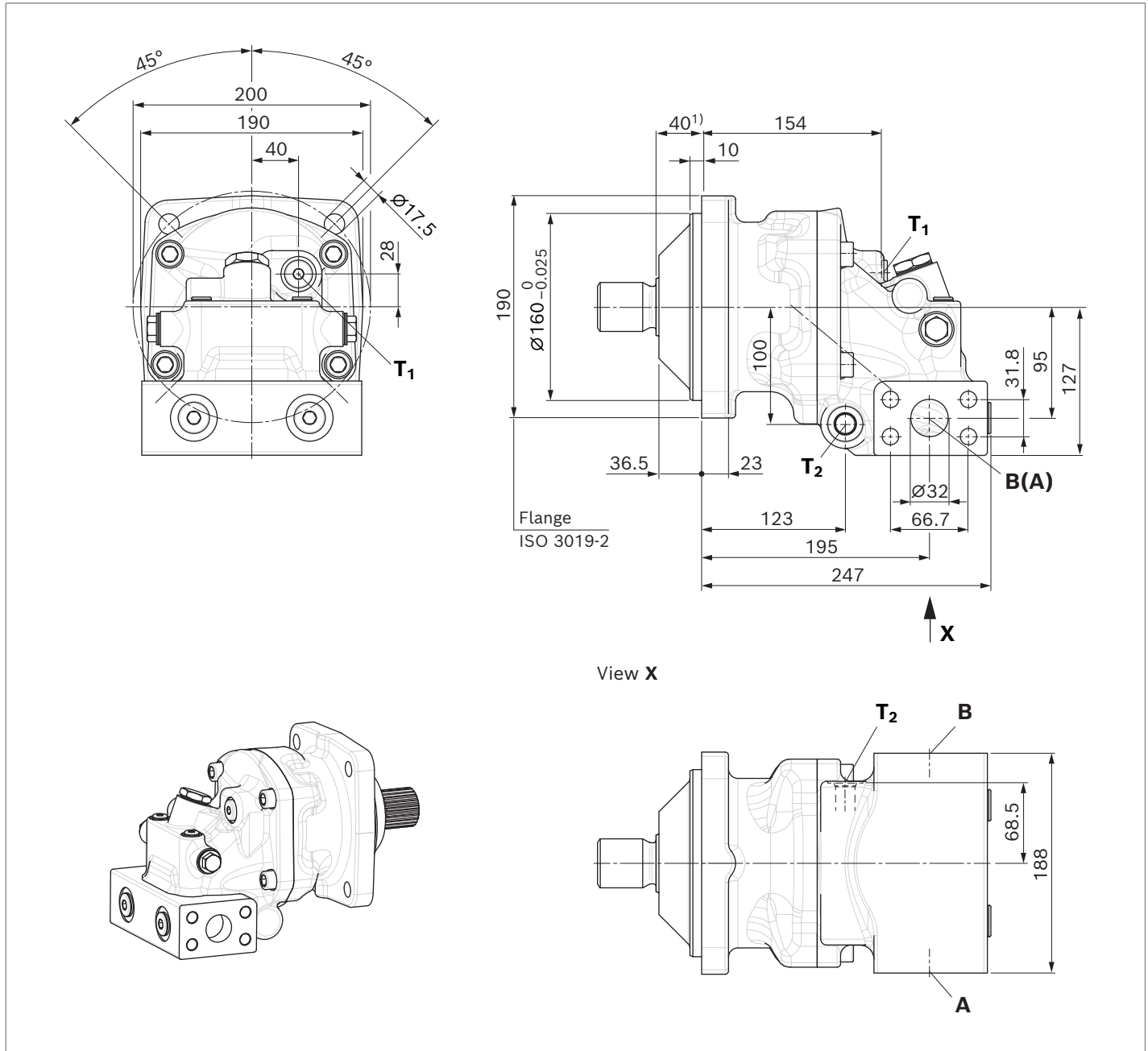

Ports		Standard	Size	p_{max} [bar] ²⁾	State ⁵⁾
A, B	Working port Fastening thread A/B	SAE J518 DIN 13	1 1/4 in M14 × 2; 23 deep	500	O
T₁	Drain port	DIN 3852 ⁴⁾	M18 × 1.5; 12 deep	3	X ³⁾
T₂	Drain port	DIN 3852 ⁴⁾	M18 × 1.5; 12 deep	3	O ³⁾

1) To shaft collar
 2) Depending on the application, momentary pressure peaks can occur. Keep this in mind when selecting measuring devices and fittings.
 3) Depending on installation position, T₁ or T₂ must be connected (see also installation instructions on page 62).

4) The countersink may be deeper than specified in the standard.
 5) O = Must be connected (plugged on delivery)
 X = Plugged (in normal operation)

Dimensions A2FE, sizes 107 and 125

SAE working ports at bottom (11)

A2FEM sizes 107 and 125

A2FEH sizes 107 and 125

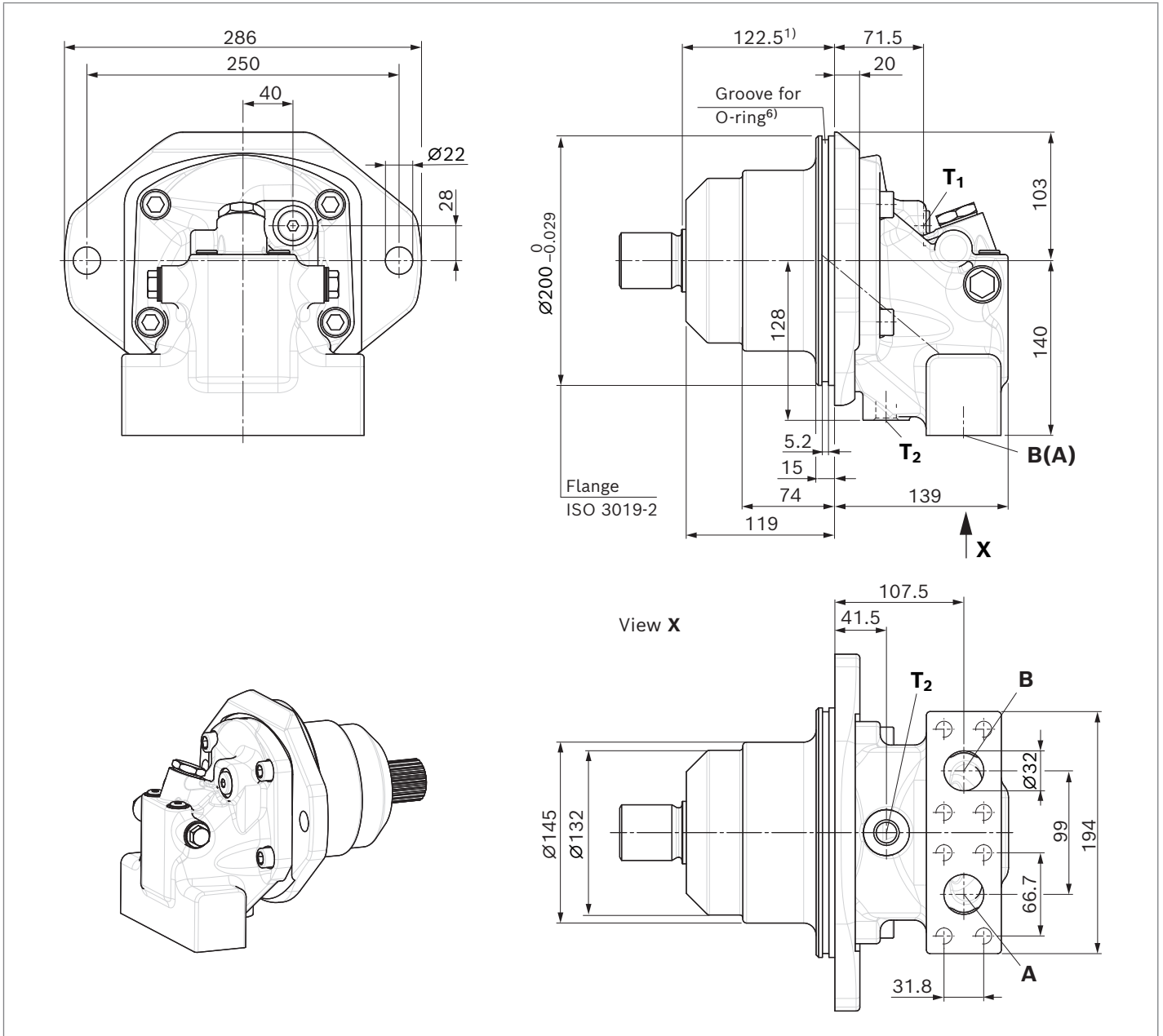

Ports		Standard	Size	p_{max} [bar] ²⁾	State ⁵⁾
A, B	Working port	SAE J518	1 1/4 in	500	O
	Fastening thread A/B	DIN 13	M14 × 2; 23 deep		
T₁	Drain port	DIN 3852 ⁴⁾	M18 × 1.5; 12 deep	3	X ³⁾
T₂	Drain port	DIN 3852 ⁴⁾	M18 × 1.5; 12 deep	3	O ³⁾

- 1) To shaft collar
- 2) Depending on the application, momentary pressure peaks can occur. Keep this in mind when selecting measuring devices and fittings.
- 3) Depending on installation position, T₁ or T₂ must be connected (see also installation instructions on page 62).
- 4) The countersink may be deeper than specified in the standard.
- 5) O = Must be connected (plugged on delivery)
 X = Plugged (in normal operation)
- 6) O-ring $\varnothing 192 \times 4$ not included in the scope of delivery.

SAE working ports at rear (01)

A2FEM sizes 107 and 125

A2FEH sizes 107 and 125

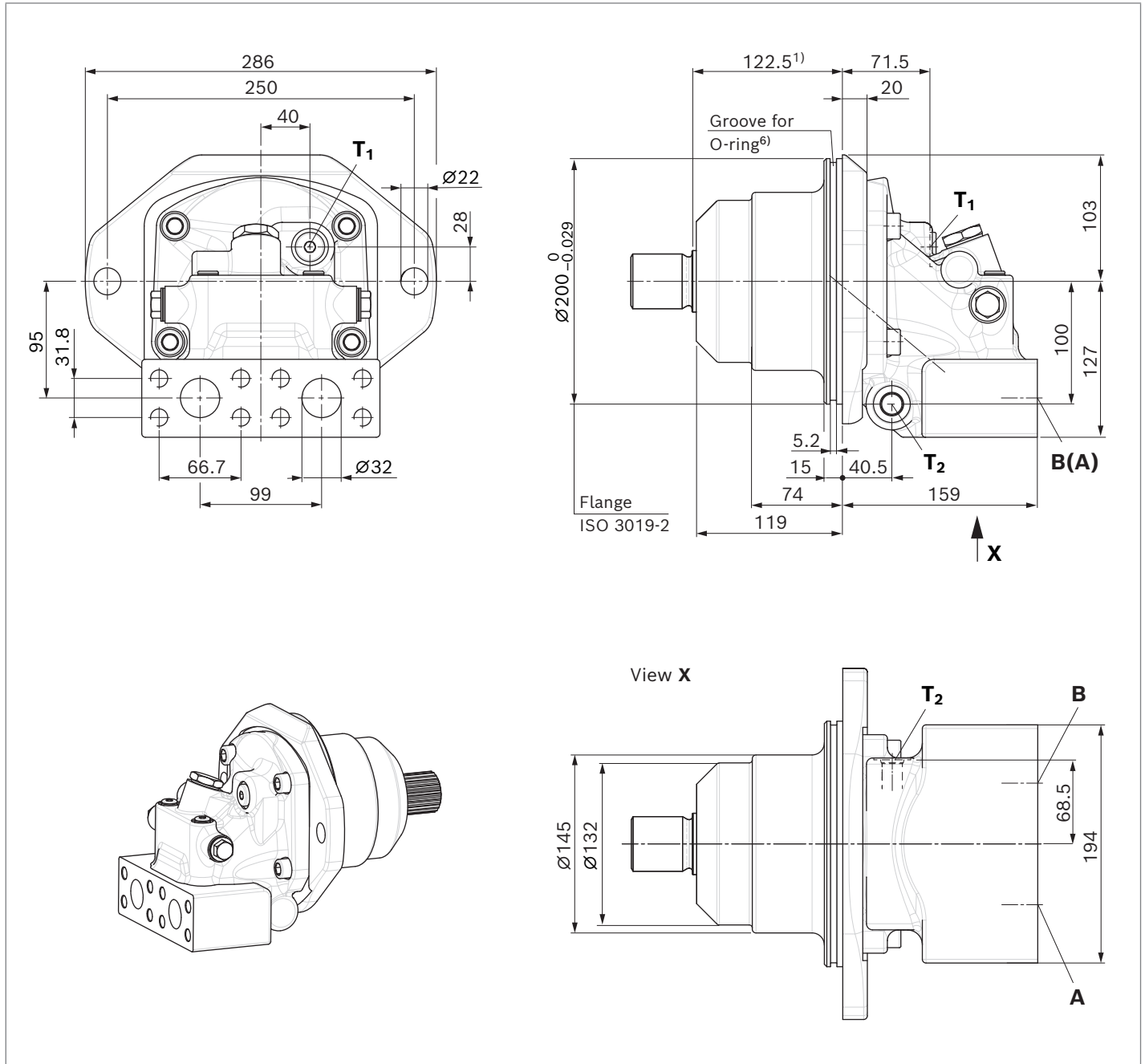

Ports	Standard	Size	p_{max} [bar] ²⁾	State ⁵⁾
A, B	SAE J518 DIN 13	1 1/4 in M14 × 2; 23 deep	500	O
T₁	DIN 3852 ⁴⁾	M18 × 1.5; 12 deep	3	X ³⁾
T₂	DIN 3852 ⁴⁾	M18 × 1.5; 12 deep	3	O ³⁾

1) To shaft collar
 2) Depending on the application, momentary pressure peaks can occur. Keep this in mind when selecting measuring devices and fittings.
 3) Depending on installation position, T₁ or T₂ must be connected (see also installation instructions on page 62).

4) The countersink may be deeper than specified in the standard.
 5) O = Must be connected (plugged on delivery)
 X = Plugged (in normal operation)
 6) O-ring Ø192 × 4 not included in the scope of delivery.

SAE working ports at side, opposite (02)

A2FEM sizes 107 and 125

A2FEH sizes 107 and 125

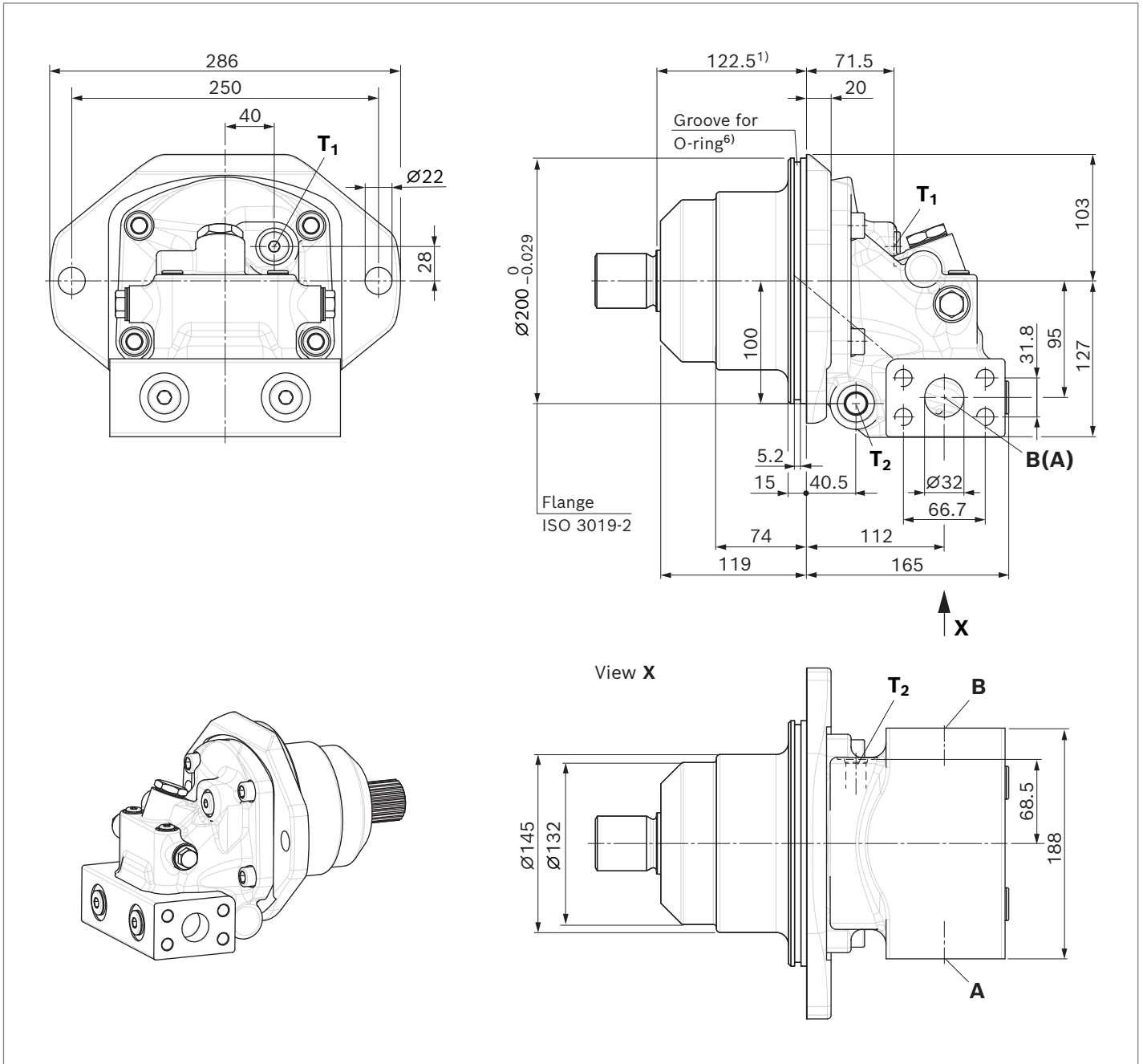

Ports		Standard	Size	p_{max} [bar] ²⁾	State ⁵⁾
A, B	Working port Fastening thread A/B	SAE J518 DIN 13	1 1/4 in M14 × 2; 23 deep	500	O
T₁	Drain port	DIN 3852 ⁴⁾	M18 × 1.5; 12 deep	3	X ³⁾
T₂	Drain port	DIN 3852 ⁴⁾	M18 × 1.5; 12 deep	3	O ³⁾

- 1) To shaft collar
- 2) Depending on the application, momentary pressure peaks can occur. Keep this in mind when selecting measuring devices and fittings.
- 3) Depending on installation position, T₁ or T₂ must be connected (see also installation instructions on page 62).
- 4) The countersink may be deeper than specified in the standard.
- 5) O = Must be connected (plugged on delivery)
X = Plugged (in normal operation)
- 6) O-ring Ø192 × 4 not included in the scope of delivery.

Drive shafts, sizes 107 and 125

▼ Splined shaft DIN 5480, Size 107²⁾

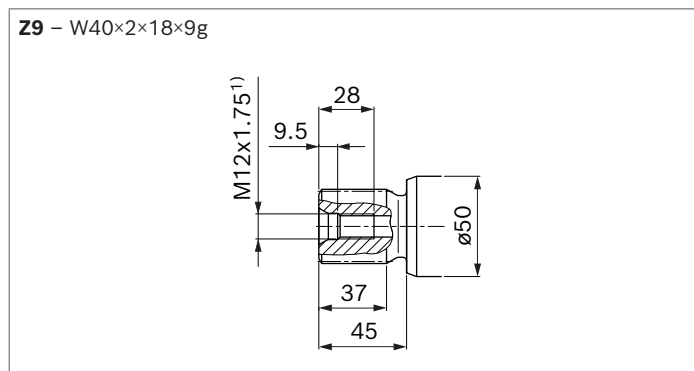

▼ Parallel keyed shaft DIN 6885, Size 107²⁾

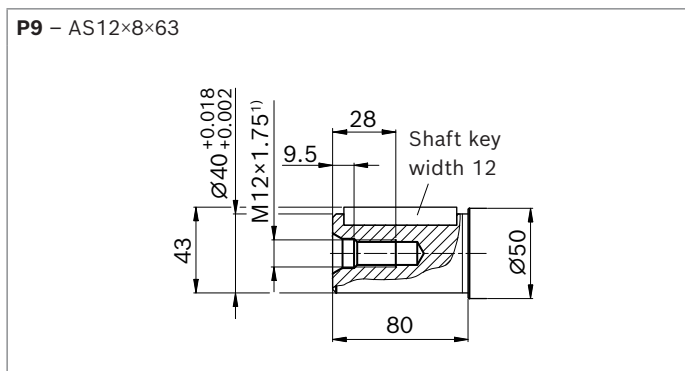

▼ Splined shaft DIN 5480, Sizes 107²⁾ and 125

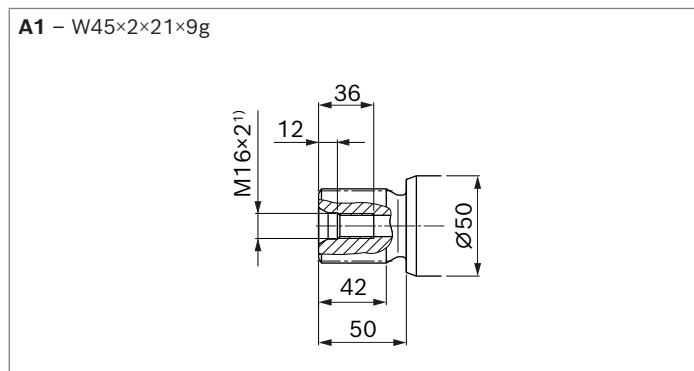

▼ Parallel keyed shaft DIN 6885, Sizes 107²⁾ and 125

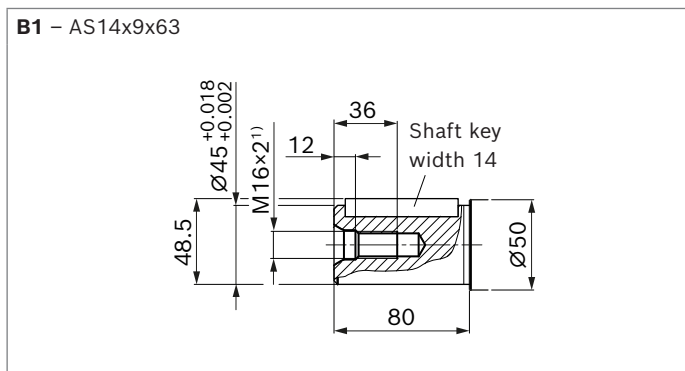

1) Center bore according to DIN 332 (thread according to DIN 13)
2) Not available for A2FMN, A2FEN (pressure range 300 to 350 bar)

Dimensions A2FM, sizes 160 and 180

SAE working ports at bottom (11)

A2FMM sizes 160 and 180

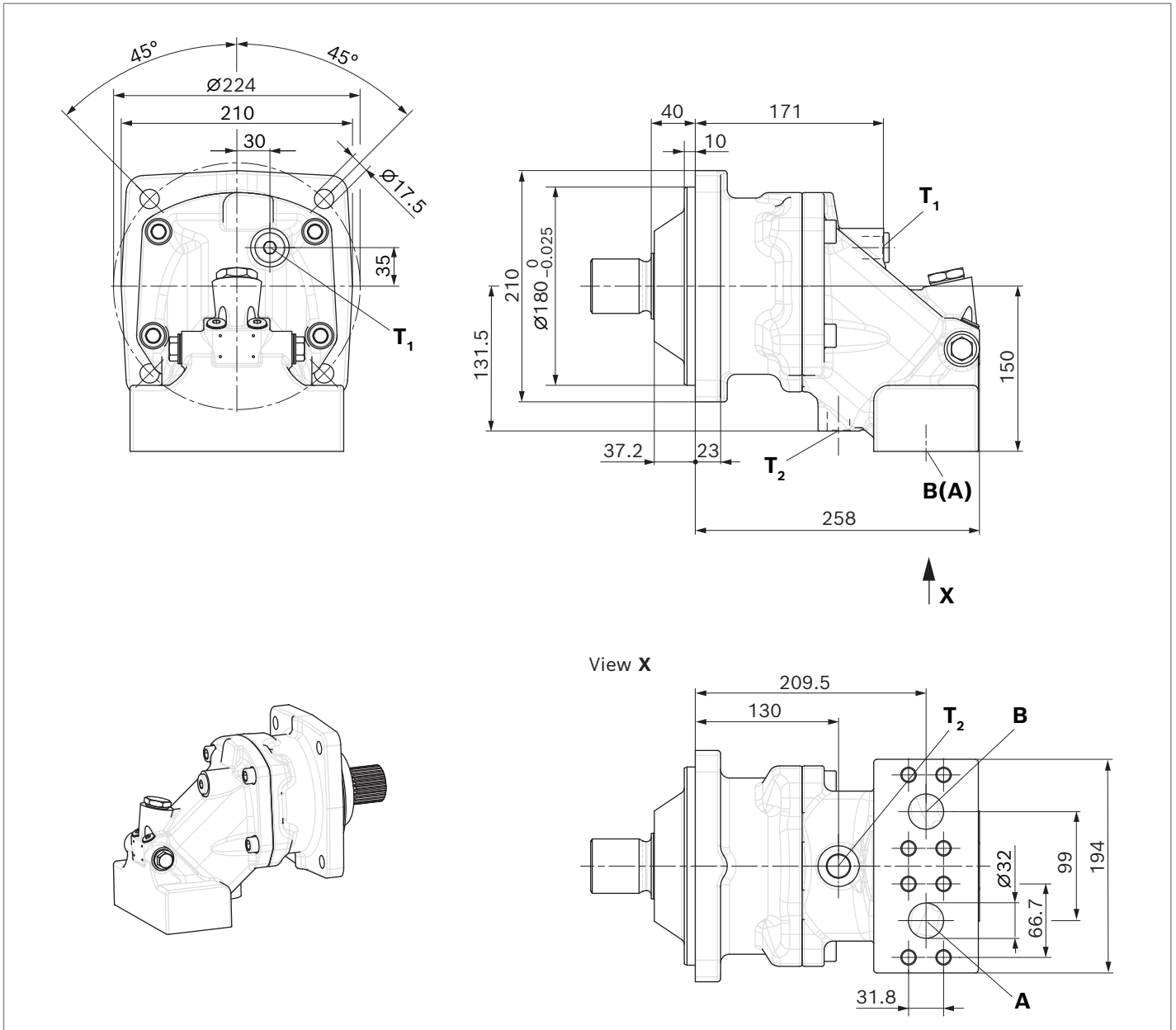

Ports		Standard	Size	p_{max} [bar] ²⁾	State ⁵⁾
A, B	Working port	SAE J518	1 1/4 in	450	O
	Fastening thread A/B	DIN 13	M14 x 2; 23 deep		
T_1	Drain port	DIN 3852 ⁴⁾	M22 x 1.5; 14 deep	3	X ³⁾
T_2	Drain port	DIN 3852 ⁴⁾	M22 x 1.5; 14 deep	3	O ³⁾

- 1) To shaft collar
- 2) Depending on the application, momentary pressure peaks can occur. Keep this in mind when selecting measuring devices and fittings.
- 3) Depending on installation position, T_1 or T_2 must be connected (see also installation instructions on page 62).
- 4) The countersink may be deeper than specified in the standard.
- 5) O = Must be connected (plugged on delivery)
 X = Plugged (in normal operation)

SAE working ports at rear (01)

A2FMM sizes 160 and 180

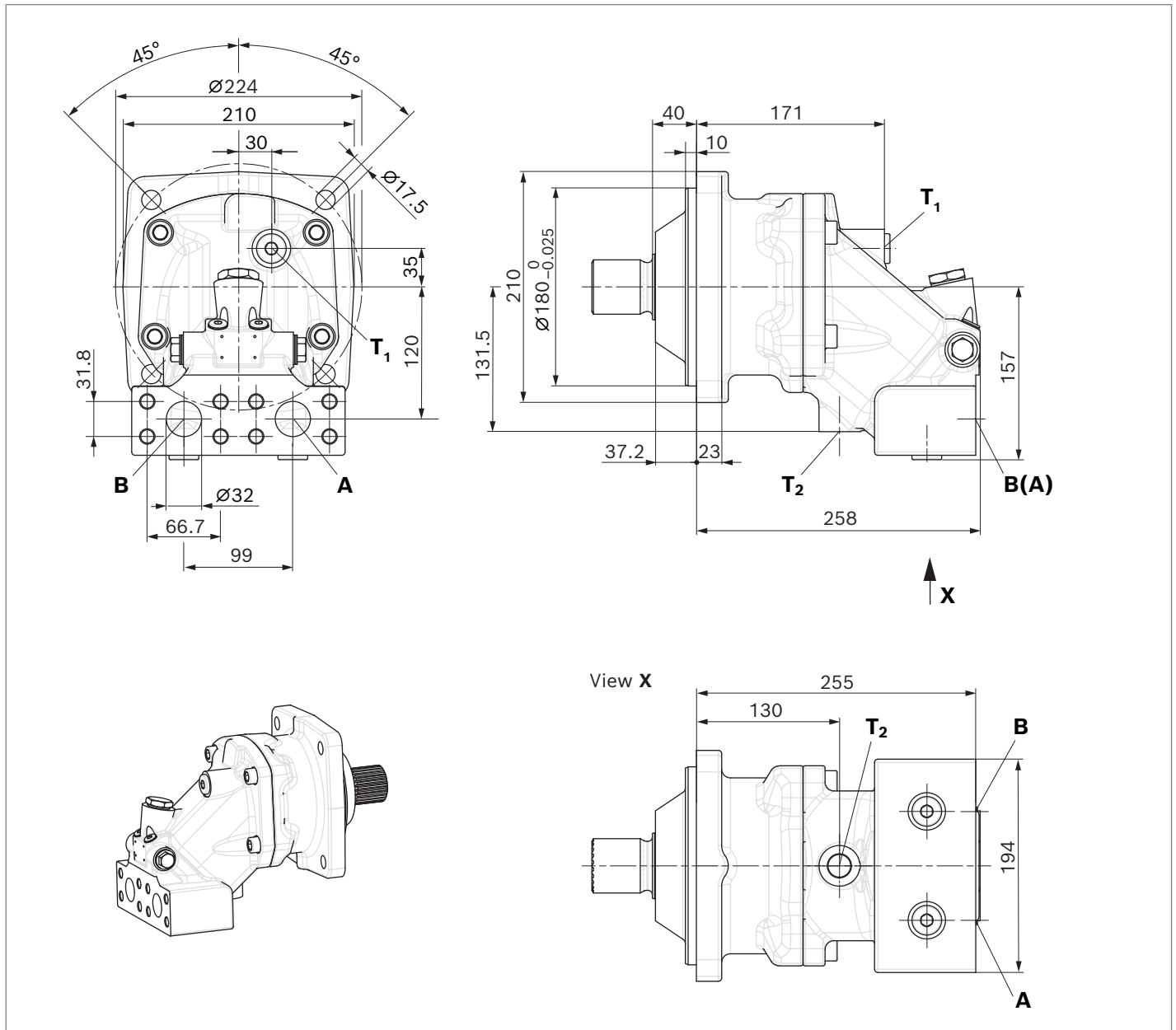

Ports		Standard	Size	p_{max} [bar] ²⁾	State ⁵⁾
A, B	Working port Fastening thread A/B	SAE J518 DIN 13	1 1/4 in M14 × 2; 23 deep	450	O
T₁	Drain port	DIN 3852 ⁴⁾	M22 × 1.5; 14 deep	3	X ³⁾
T₂	Drain port	DIN 3852 ⁴⁾	M22 × 1.5; 14 deep	3	O ³⁾

1) To shaft collar
2) Depending on the application, momentary pressure peaks can occur. Keep this in mind when selecting measuring devices and fittings.
3) Depending on installation position, T₁ or T₂ must be connected (see also installation instructions on page 62).

4) The countersink may be deeper than specified in the standard.
5) O = Must be connected (plugged on delivery)
X = Plugged (in normal operation)

SAE working ports at side, opposite (02)

A2FMM sizes 160 and 180

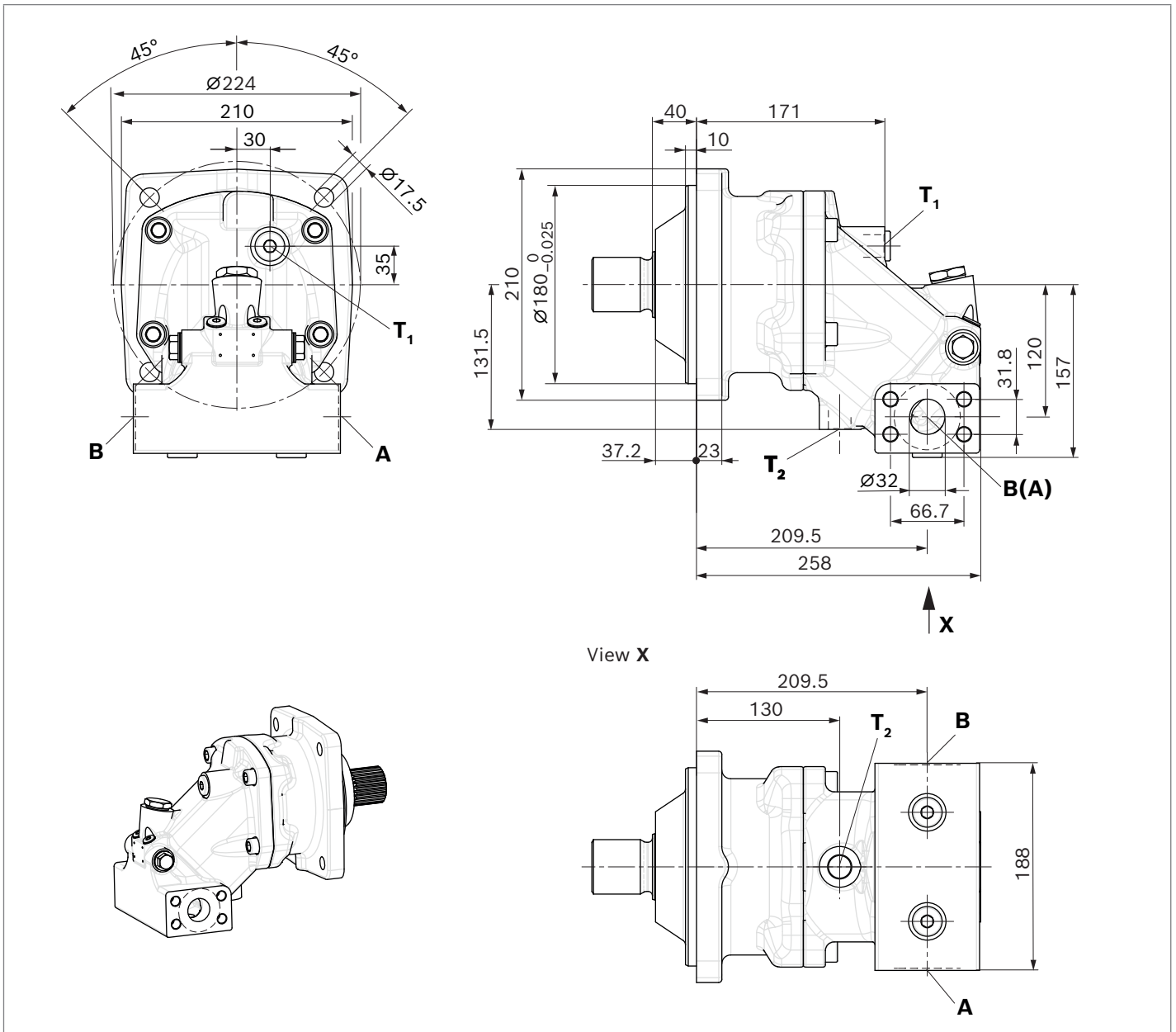

Ports		Standard	Size	p_{max} [bar] ²⁾	State ⁵⁾
A, B	Working port	SAE J518	1 1/4 in	450	O
	Fastening thread A/B	DIN 13	M14 × 2; 23 deep		
T₁	Drain port	DIN 3852 ⁴⁾	M22 × 1.5; 14 deep	3	X ³⁾
T₂	Drain port	DIN 3852 ⁴⁾	M22 × 1.5; 14 deep	3	O ³⁾

1) To shaft collar
 2) Depending on the application, momentary pressure peaks can occur. Keep this in mind when selecting measuring devices and fittings.
 3) Depending on installation position, T₁ or T₂ must be connected (see also installation instructions on page 62).

4) The countersink may be deeper than specified in the standard.
 5) O = Must be connected (plugged on delivery)
 X = Plugged (in normal operation)

Dimensions A2FE, sizes 160 and 180

SAE working ports at bottom (11)

A2FEM sizes 160 and 180

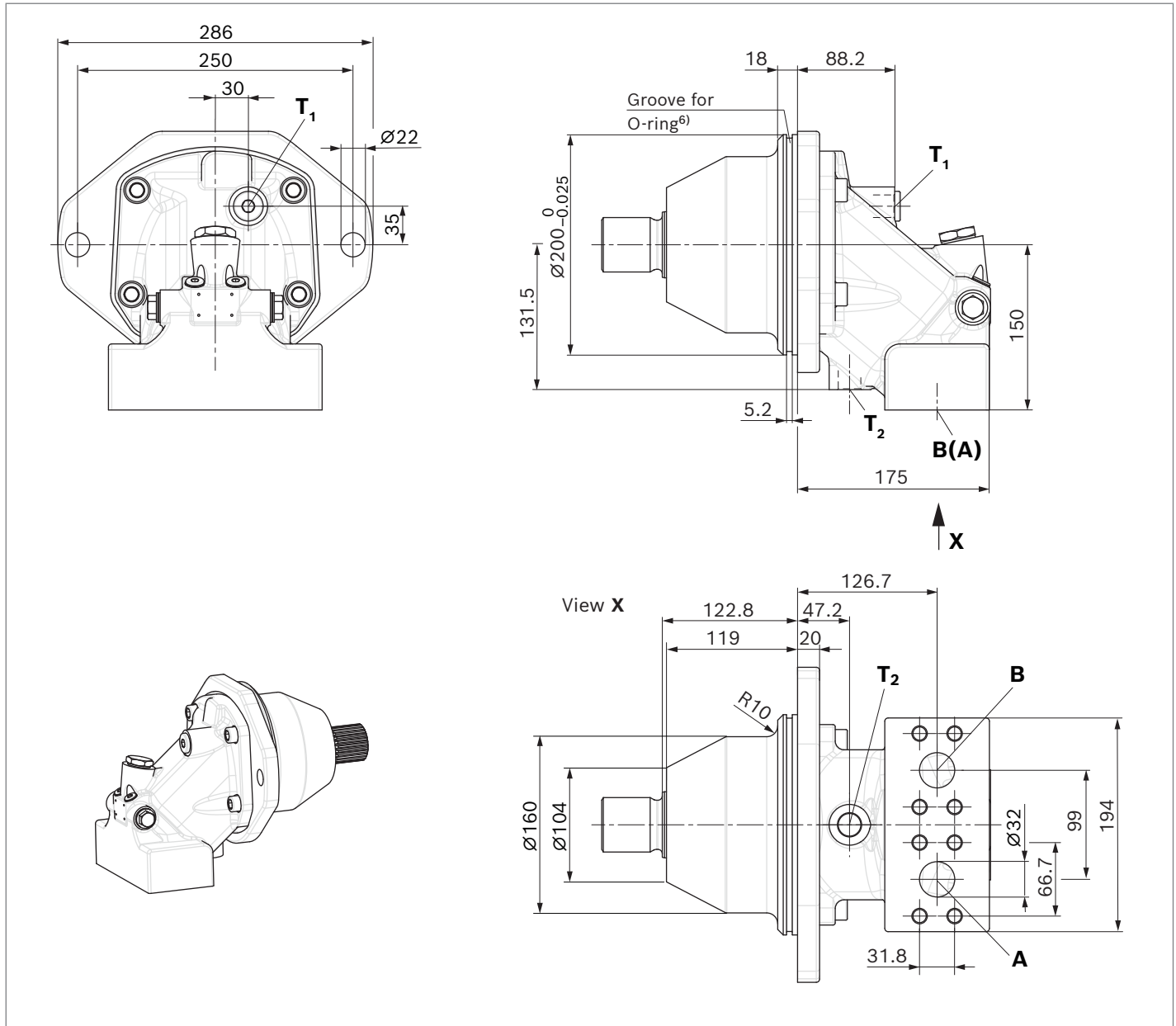

Ports		Standard	Size	p_{max} [bar] ²⁾	State ⁵⁾
A, B	Working port Fastening thread A/B	SAE J518 DIN 13	1 1/4 in M14 × 2; 23 deep	450	O
T₁	Drain port	DIN 3852 ⁴⁾	M22 × 1.5; 14 deep	3	X ³⁾
T₂	Drain port	DIN 3852 ⁴⁾	M22 × 1.5; 14 deep	3	O ³⁾

1) To shaft collar
 2) Depending on the application, momentary pressure peaks can occur. Keep this in mind when selecting measuring devices and fittings.
 3) Depending on installation position, T₁ or T₂ must be connected (see also installation instructions on page 62).

4) The countersink may be deeper than specified in the standard.
 5) O = Must be connected (plugged on delivery)
 X = Plugged (in normal operation)
 6) O-ring Ø192 × 4 not included in the scope of delivery.

SAE working ports at rear (01)
A2FEM sizes 160 and 180

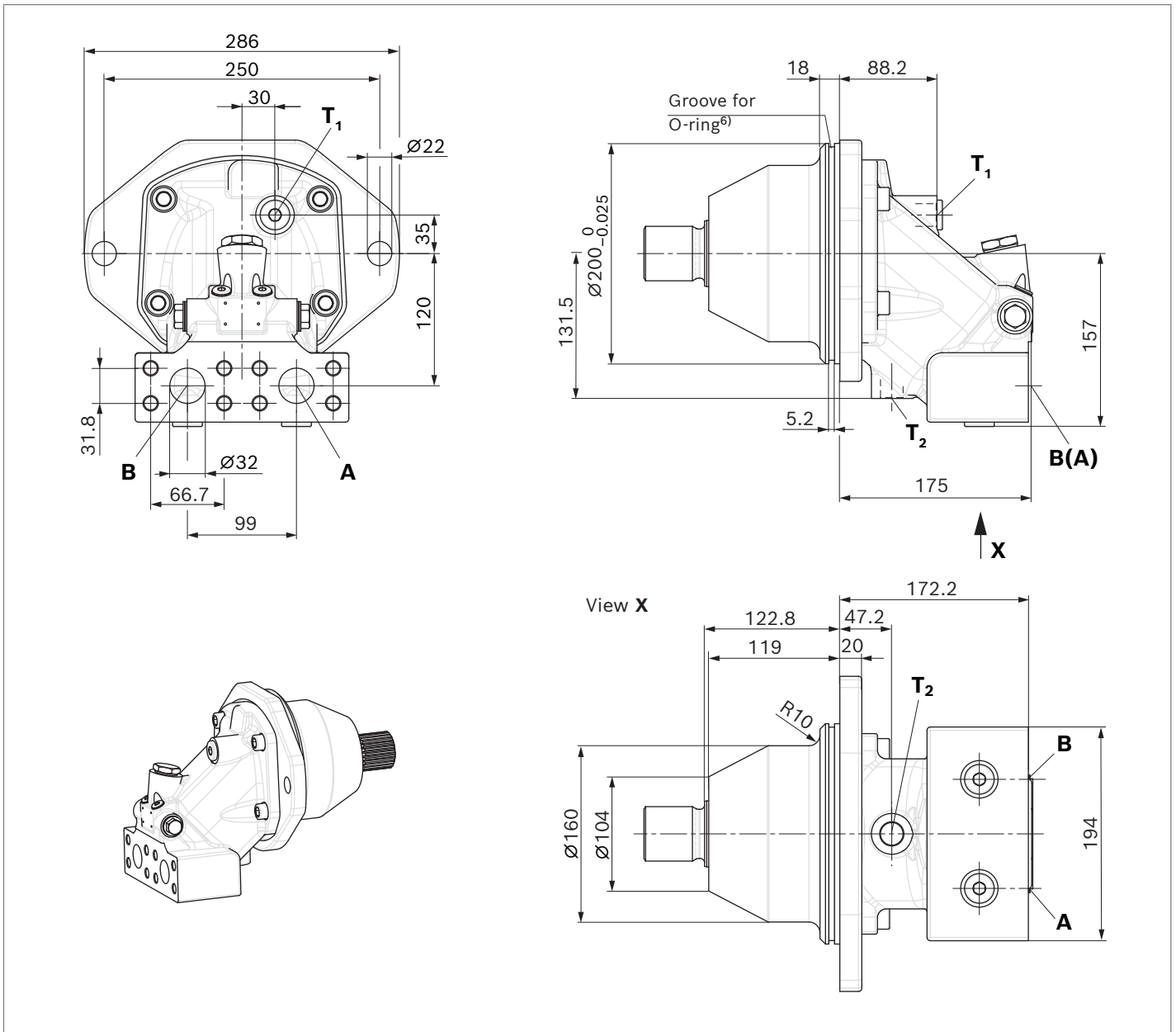

Ports		Standard	Size	p_{max} [bar] ²⁾	State ⁵⁾
A, B	Working port Fastening thread A/B	SAE J518 DIN 13	1 1/4 in M14 × 2; 23 deep	450	O
T₁	Drain port	DIN 3852 ⁴⁾	M22 × 1.5; 14 deep	3	X ³⁾
T₂	Drain port	DIN 3852 ⁴⁾	M22 × 1.5; 14 deep	3	O ³⁾

1) To shaft collar
 2) Depending on the application, momentary pressure peaks can occur. Keep this in mind when selecting measuring devices and fittings.
 3) Depending on installation position, T₁ or T₂ must be connected (see also installation instructions on page 62).

4) The countersink may be deeper than specified in the standard.
 5) O = Must be connected (plugged on delivery)
 X = Plugged (in normal operation)
 6) O-ring Ø192 × 4 not included in the scope of delivery.

SAE working ports at side (02)

A2FEM sizes 160 and 180

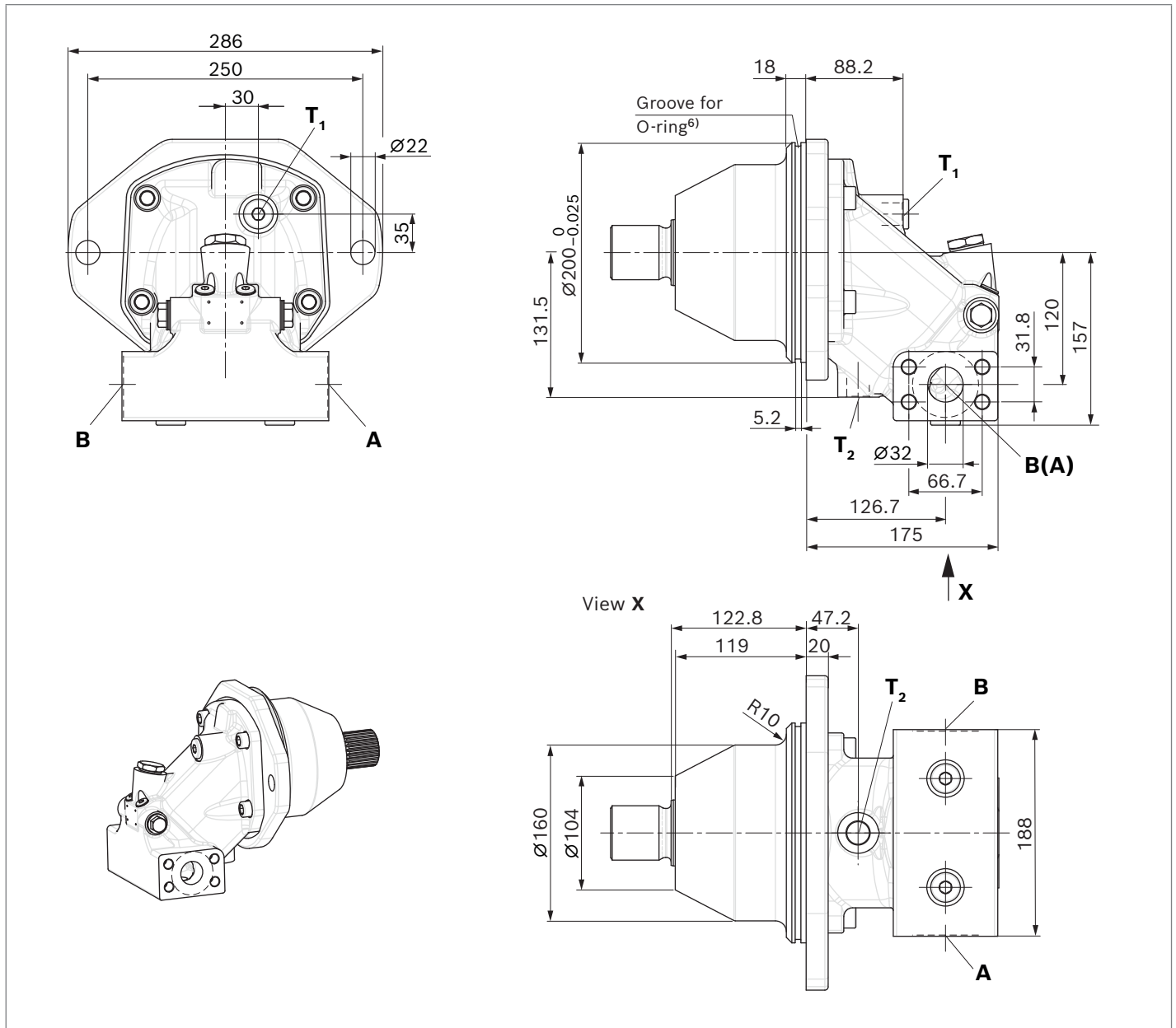

Ports	Standard	Size	p_{max} [bar] ²⁾	State ⁵⁾
A, B	SAE J518 DIN 13	1 1/4 in M14 × 2; 23 deep	450	O
T ₁	DIN 3852 ⁴⁾	M22 × 1.5; 14 deep	3	X ³⁾
T ₂	DIN 3852 ⁴⁾	M22 × 1.5; 14 deep	3	O ³⁾

1) To shaft collar
 2) Depending on the application, momentary pressure peaks can occur. Keep this in mind when selecting measuring devices and fittings.
 3) Depending on installation position, T₁ or T₂ must be connected (see also installation instructions on page 62).

4) The countersink may be deeper than specified in the standard.
 5) O = Must be connected (plugged on delivery)
 X = Plugged (in normal operation)
 6) O-ring $\varnothing 192 \times 4$ not included in the scope of delivery.

Drive shafts, sizes 160 and 180

▼ Splined shaft DIN 5480, Size 160

A1 – W45×2×21×9g

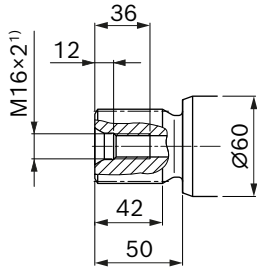

▼ Parallel keyed shaft DIN 6885, Size 160

B1 – AS14×9×70

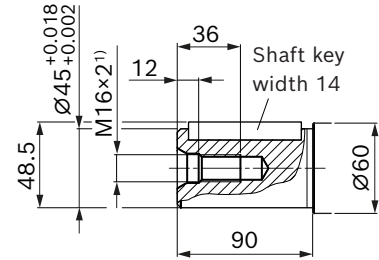

▼ Splined shaft DIN 5480, Sizes 160 and 180

A2 – W50×2×24×9g

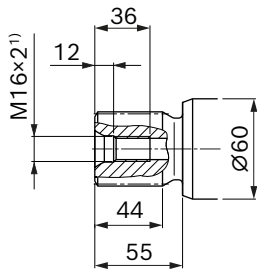

▼ Parallel keyed shaft DIN 6885, Sizes 160 and 180

B2 – AS14×9×70

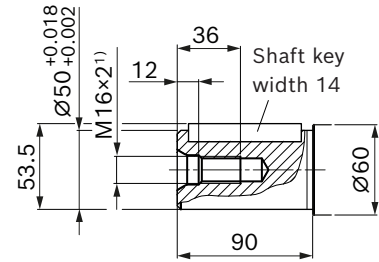

1) Center bore according to DIN 332 (thread according to DIN 13)

Flushing and boost-pressure valve, integrated

The flushing and boost-pressure valve is used to remove heat from the hydraulic circuit.

In a closed circuit, it is used for flushing the housing and safeguarding the minimum boost pressure.

Hydraulic fluid is directed from the respective low-pressure side into the motor housing. This is then fed into the reservoir, together with the leakage. In the closed circuit, the removed hydraulic fluid must be replaced by cooled hydraulic fluid supplied by the boost pump.

▼ Circuit diagram, sizes 23 to 107(N)

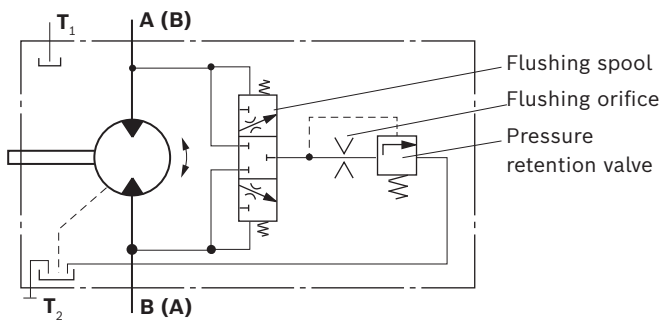

▼ Circuit diagram, sizes 107 to 180

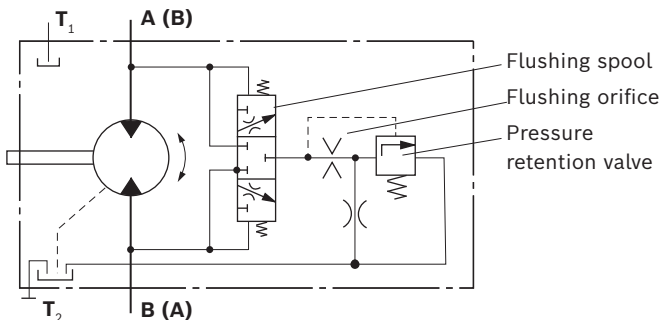

Cracking pressure of pressure retention valve

(observe when setting the primary valve)

- Size 23 to 180, fixed setting 16 bar

Switching pressure of flushing spool

- Sizes 23 to 107(N)
 $\Delta p = 8 \pm 1$ bar
- Sizes 107 to 180
 $\Delta p = 17.5 \pm 1.5$ bar

Flushing flow

Orifices can be used to adjust the flushing flows as required. The following parameters are based on:

$$\Delta p_{ND} = p_{ND} - p_G = 25 \text{ bar and } v = 10 \text{ mm}^2/\text{s}$$

(p_{ND} = low pressure, p_G = case pressure)

Size	Code	Orifice dia. [mm]	Flushing flow q_v [l/min]	
23, 28, 32, 37, 45, 56, 63, 80, 90, 107(N)	C	1.0	2.6	
	D	1.3	4	
	E	1.5	6	
	F	1.7	7.4	
	G	1.8	8.5	
	H	2.0	10	
	I	2.3	11.4	
	J	3	12.5	
	107, 125, 160, 180	D	1.2	4
		E	1.4	6
G		1.8	8.5	
H		2.0	10	
K		2.5	15	
L		2.8	18	
M		3.1	21	
N		3.8	27	
O	4.0	31		
P	5.0	37		

Pressure relief valve

The MHDB pressure relief valves (see data sheets 64602 and 64612) protect the hydraulic motor from overload. As soon as the set cracking pressure is reached, the hydraulic fluid flows from the high-pressure side to the low-pressure side.

The pressure relief valves are only available in conjunction with the working ports 07, 08 and 09 (for the counterbalance valve for mounting to working ports 07 and 08, see next page).

Cracking pressure setting range 50 to 420 bar

For versions "with pressure sequencing stage" 09S, a higher pressure setting can be implemented by connecting an external pilot pressure of 25 up to 30 bar at port P_{St}.

When ordering, state in plain text:

- ▶ Cracking pressure of pressure relief valve
- ▶ Cracking pressure with pilot pressure applied to P_{St} (only with version 09S)

▼ Circuit diagram version without pressure sequencing stage 09R

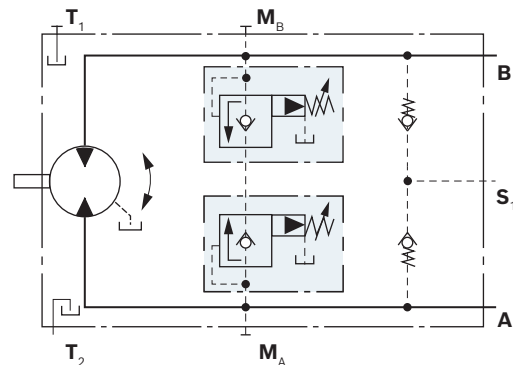

▼ Circuit diagram version with pressure sequencing stage 09S

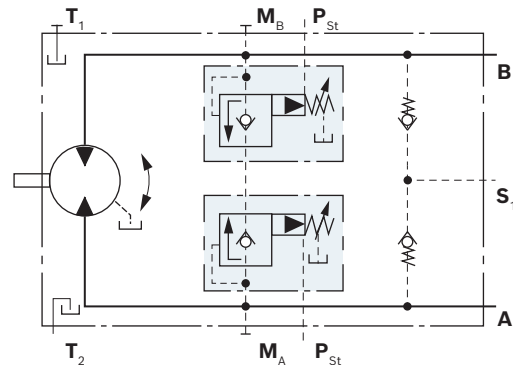

Permissible inlet flow or pressure for version with pressure relief valves

Motor NG	Without valve		Limited values when using pressure relief valves (DBV)			
	p_{nom}/p_{max} [bar]	$q_{V max}$ [l/min]	DBV NG	p_{nom}/p_{max} [bar]	q_v [l/min]	Code
45	400/450	225	22	350/420	240	09R, 09S
56		280				
63		315				
80		360				
90		405				
107		427				
125		500				
					400	

DBV = Pressure relief valve

Dimensions A2FM

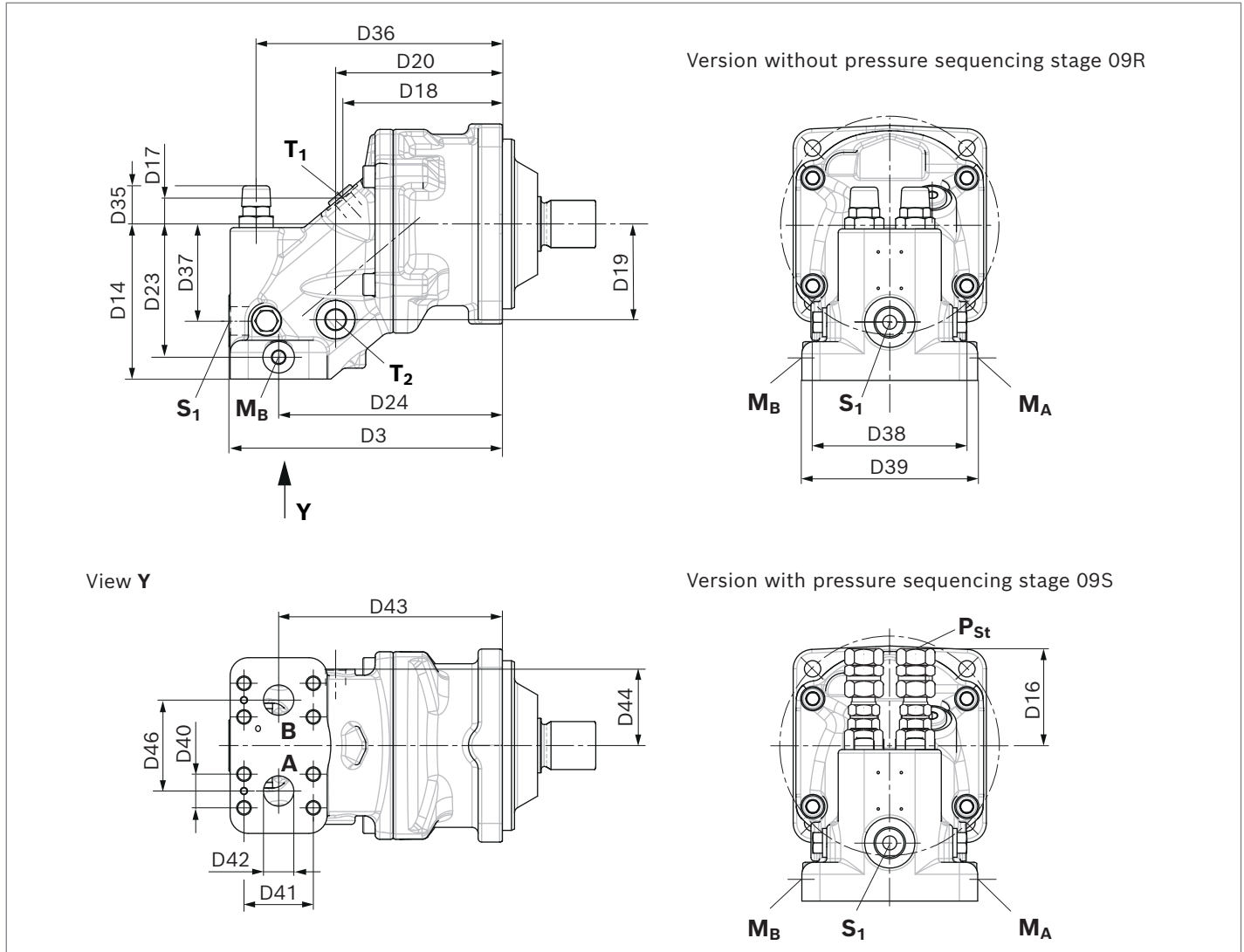

Size		D3	D14	D16	D17	D18	D19	D20	D23	D24	D35	D36	D37	D38	D39	D40
45, 56, 63	MHDB..22	206	120	74	22	114	70	113	105	163	32.5	182	75	137	130	23.8
80, 90	MHDB..22	225.5	128	73	21.3	131.5	79	137.5	110	184.5	31.5	203	80	127	145	27.8
107, 125	MHDB..32	258	130	73.5	21	147.5	98	130	110	201	32	228	80	127	144	31.8

Size		D41	D42	D43	D44	D46	A, B	S ₁	M _A , M _B	P _{St}	T ₁ , T ₂
45, 56, 63	MHDB..22	50.8	∅19	163	55.5	75	3/4 in	M22 × 1.5; 14 deep	M12 × 1.5; 12 deep	G 1/4	M18 × 1.5; 12 deep
80, 90	MHDB..22	57.2	∅25	184.5	63	75	1 in	M26 × 1.5; 16 deep	M12 × 1.5; 12 deep	G 1/4	M18 × 1.5; 12 deep
107, 125	MHDB..32	66.7	∅32	201	74	84	1 1/4 in	M26 × 1.5; 16 deep	M12 × 1.5; 12 deep	G 1/4	M18 × 1.5; 12 deep

Ports		Standard	Size	p _{max} [bar] ¹⁾	State ³⁾
A, B	Working port	SAE J518	See table above	420	O
S₁	Boost port (for working ports 09R/09S only)	DIN 3852 ²⁾	See table above	5	O
M_A, M_B	Measuring port pressure A/B	DIN 3852 ²⁾	See table above	420	X
P_{St}	Pilot pressure port (for working ports 09S only)	DIN ISO 228	See table above	30	O
T₁, T₂	Drain port	DIN 3852 ²⁾	See table above	3	X, O ⁴⁾

1) Depending on the application, momentary pressure peaks can occur.

Keep this in mind when selecting measuring devices and fittings.

2) The countersink may be deeper than specified in the standard.

3) O = Must be connected (plugged on delivery)

X = Plugged (in normal operation)

4) Depending on installation position, T₁ or T₂ must be connected (see also installation instructions on page 62).

Dimensions A2FE

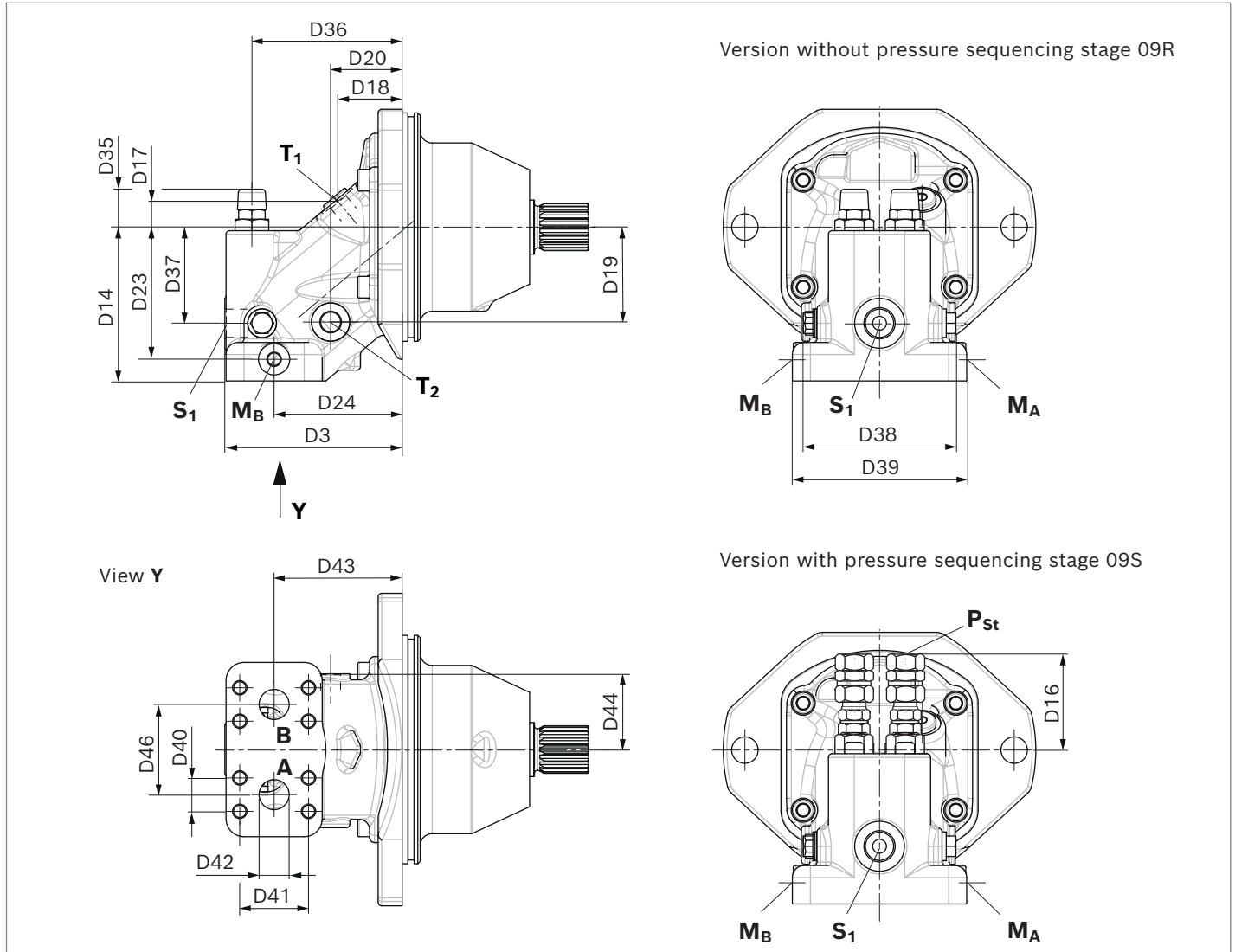

Size		D3	D14	D16	D17	D18	D19	D20	D23	D24	D35	D36	D37	D38	D39	D40
45, 56, 63	MHDB..22	145	120	74	22	54	70	53	105	103	32.5	182	75	137	130	23.8
80, 90	MHDB..22	147.5	128	73	21.3	53.5	79	59.5	110	106.5	31.5	203	80	127	145	27.8
107, 125	MHDB..32	175.5	130	73.5	21	65	98	47.5	110	118.5	32	145.5	80	127	144	31.8

Size		D41	D42	D43	D44	D46	A, B	S ₁	M _A , M _B	P _{St}	T ₁ , T ₂
45, 56, 63	MHDB..22	50.8	∅19	103	55.5	75	3/4 in	M22 × 1.5; 14 deep	M12 × 1.5; 12 deep	G 1/4	M18 × 1.5; 12 deep
80, 90	MHDB..22	57.2	∅25	106.5	63	75	1 in	M26 × 1.5; 16 deep	M12 × 1.5; 12 deep	G 1/4	M18 × 1.5; 12 deep
107, 125	MHDB..32	66.7	∅32	118.5	74	84	1 1/4 in	M26 × 1.5; 16 deep	M12 × 1.5; 12 deep	G 1/4	M18 × 1.5; 12 deep

Ports		Standard	Size	p _{max} [bar] ¹⁾	State ³⁾
A, B	Working port	SAE J518	See table above	420	O
S₁	Boost port (for working ports 09R/09S only)	DIN 3852 ²⁾	See table above	5	O
M_A, M_B	Measuring port pressure A/B	DIN 3852 ²⁾	See table above	420	X
P_{St}	Pilot pressure port (for working ports 09S only)	DIN ISO 228	See table above	30	O
T₁, T₂	Drain port	DIN 3852 ²⁾	See table above	3	X, O ⁴⁾

- 1) Depending on the application, momentary pressure peaks can occur. Keep this in mind when selecting measuring devices and fittings.
- 2) The countersink may be deeper than specified in the standard.
- 3) O = Must be connected (plugged on delivery)
 X = Plugged (in normal operation)
- 4) Depending on installation position, T₁ or T₂ must be connected (see also installation instructions on page 62).

Counterbalance valve BVD/BVE

Function

Counterbalance valves for travel drives and winches should reduce the danger of overspeed and cavitation of axial piston motors in open circuits. Cavitation occurs if, during braking, when going downhill or during the load-lowering process, the motor speed is greater than it should be for the given inlet flow and thus the supply pressure falls sharply.

If the supply pressure falls below the value specified for the relevant counterbalance valve, the counterbalance spool moves into the closed position. The cross-sectional area of the counterbalance valve return passage is then reduced, creating a bottleneck in the return flow of the hydraulic fluid. The pressure increases and brakes the motor until the rotational speed of the motor reaches the specified value for the given inlet flow.

Notice

- ▶ BVD available for sizes 45 to 125 and BVE available for sizes 107 and 125.
- ▶ The counterbalance valve must be ordered additionally. We recommend ordering the counterbalance valve and the motor as a set.
Order example:
A2FMM90/70NWVN4Z9**07W**000 + BVD20F27S/41B-V03K16D0400S12
- ▶ The counterbalance valve does not replace the mechanical service brake and holding brake.
- ▶ Observe the detailed notes on the BVD counterbalance valve contained in data sheet 95522 and BVE in data sheet 95526!
- ▶ For the design of the brake release valve, we must know the following data for the mechanical holding brake:
 - the cracking pressure
 - the volume of the brake spool between minimum stroke (brake closed) and maximum stroke (brake released with 21 bar)
 - the required closing time for a warm device (Oil viscosity approx. 15 mm²/s)

Permissible inlet flow or pressure in case of version with counterbalance valves

Motor NG	Without valve		Limited values when using BVD/BVE			
	p_{nom}/p_{max} [bar]	$q_{V max}$ [l/min]	BVD/BVE NG	p_{nom}/p_{max} [bar]	$q_v^{1)}$ [l/min]	Code
45	400/450	225	20	350/420	220	07W
56		280				
63		315				
80		360				
90		405				
107		427				
125		500				
107		427				
125	500					

BVD = Counterbalance valve, double-acting

BVE = Counterbalance valve, single-acting

1) Restriction of input flow with counterbalance valve

Counterbalance valve for travel drives BVD..F

Application option

- ▶ Travel drive for wheeled excavators

Example circuit diagram for travel drive in wheeled excavators

A2FMM90/70NWVN4Z907W000 + BVD20F27S/41B-V03K16D0400S12

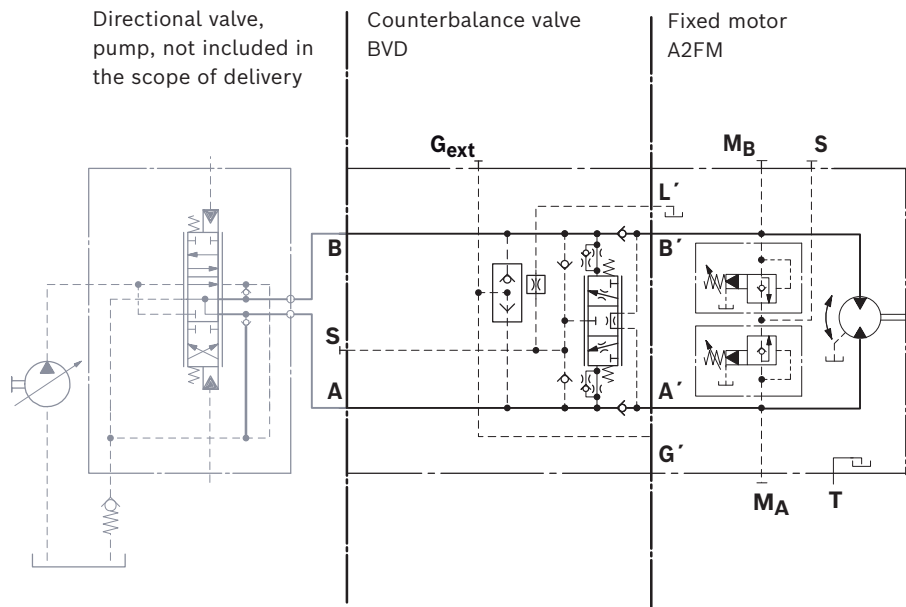

Counterbalance valve for winch drives BVD..W and BVE

Application possibilities

- ▶ Winch drives in cranes (BVD and BVE)
- ▶ Track drive in excavator crawlers (BVD)

Example circuit diagram for winch drive in cranes

A2FMM90/70NWVN4Z907W000 + BVD20W27L/41B-V01K00D0600S00

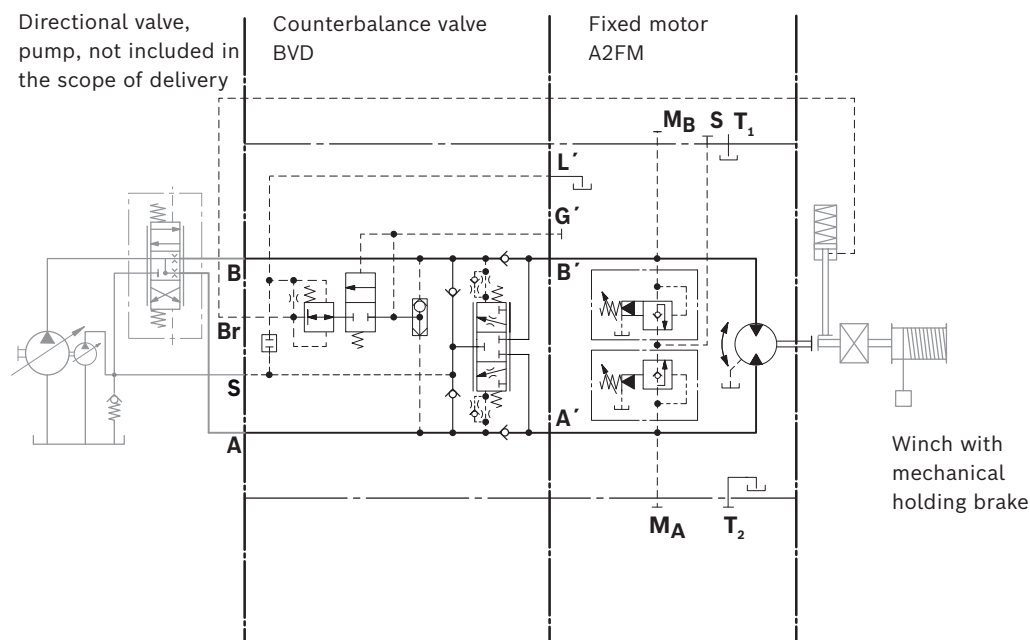

Dimensions A2FM

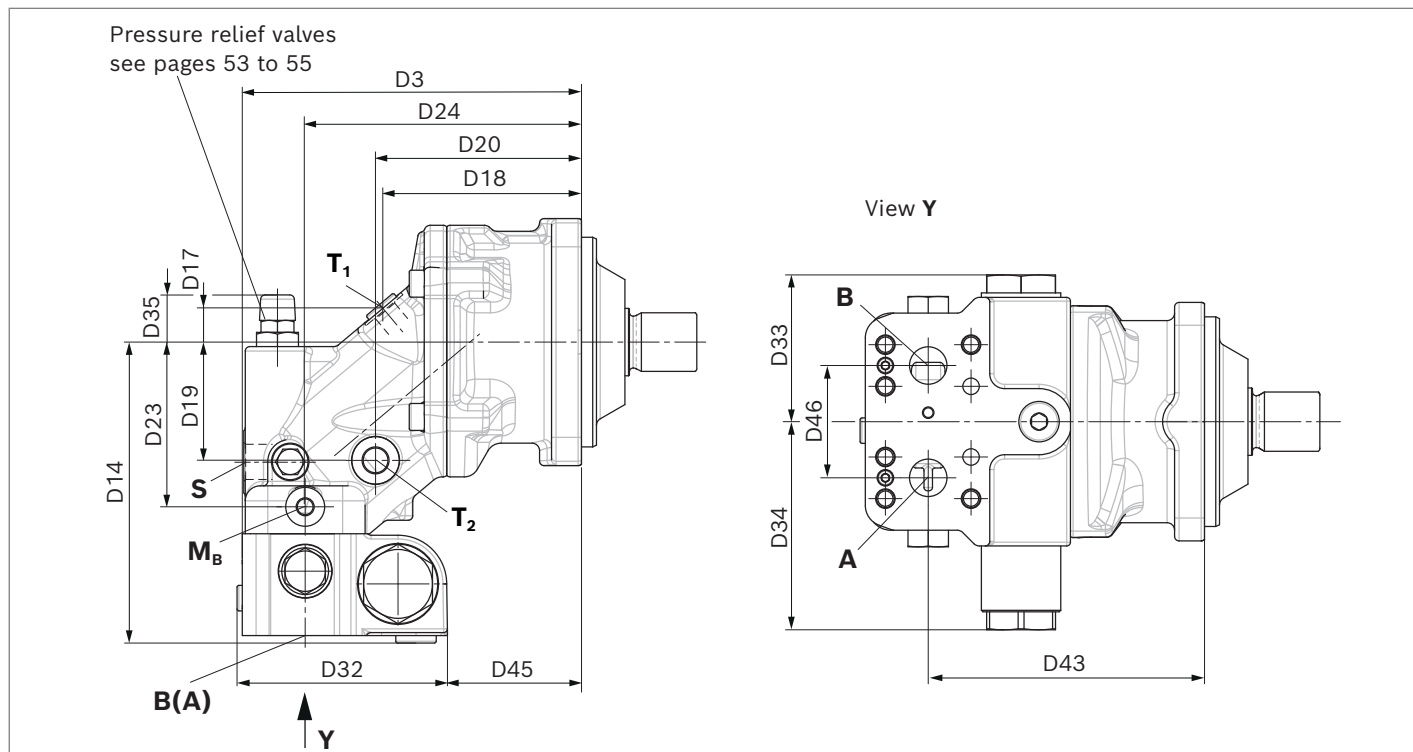

Size		D3	D14	D17	D18	D19	D20	D23	D24	D32	D33	D34	D35	D43	D45	D46
45, 56, 63	BVD20..17	205	193	22	114	70	113	105	163	140.5	98	139	32.5	163	68	75
80, 90	BVD20..27	226.5	201	21.3	131.5	79	137.5	110	184.5	140.5	98	139	31.5	184.5	95	75
107, 125	BVD20..28	258	203	21	147.5	98	130	110	201	140.5	98	139	32	201	106	84
	BVD25..38	258	220	21	147.5	98	130	110	201	158	120.5	175	32	201	94	84
	BVE25..38	258	221	21	147.5	98	130	110	201	167	137	214	32	201	85	84

Size		A, B	S	Br, G _{ext}	M _A , M _B	P _{St}	T ₁ , T ₂
45, 56, 63	BVD20..17	3/4 in	M22 × 1.5; 14 deep	M12 × 1.5; 12.5 deep	M12 × 1.5; 12 deep	G 1/4	M18 × 1.5; 12 deep
80, 90	BVD20..27	1 in	M22 × 1.5; 14 deep	M12 × 1.5; 12.5 deep	M12 × 1.5; 12 deep	G 1/4	M18 × 1.5; 12 deep
107, 125	BVD20..28	1 in	M22 × 1.5; 14 deep	M12 × 1.5; 12.5 deep	M12 × 1.5; 12 deep	G 1/4	M18 × 1.5; 12 deep
	BVD25..38	1 1/4 in	M27 × 2; 16 deep	M12 × 1.5; 12.5 deep	M12 × 1.5; 12 deep	G 1/4	M18 × 1.5; 12 deep
	BVE25..38	1 1/4 in	M27 × 2; 16 deep	M12 × 1.5; 12.5 deep	M12 × 1.5; 12 deep	G 1/4	M18 × 1.5; 12 deep

Ports		Version	Standard	Size	p _{max} [bar] ¹⁾	State ³⁾
A, B	Working port		SAE J518	See table above	420	O
S	Boost port		DIN 3852 ²⁾	See table above	30	X
Br	Brake release port, reduced high pressure	L	DIN 3852 ²⁾	See table above	30	O
G_{ext}	Brake release port, high pressure	S	DIN 3852 ²⁾	See table above	420	X
M_A, M_B	Measuring port pressure A/B		DIN 3852 ²⁾	See table above	420	X
T₁, T₂	Drain port		DIN 3852 ²⁾	See table above	3	X, O ⁴⁾

1) Depending on the application, momentary pressure peaks can occur. Keep this in mind when selecting measuring devices and fittings.

2) The countersink may be deeper than specified in the standard.

3) O = Must be connected (plugged on delivery)

X = Plugged (in normal operation)

4) Depending on installation position, T₁ or T₂ must be connected (see also installation instructions on page 62).

Dimensions A2FE

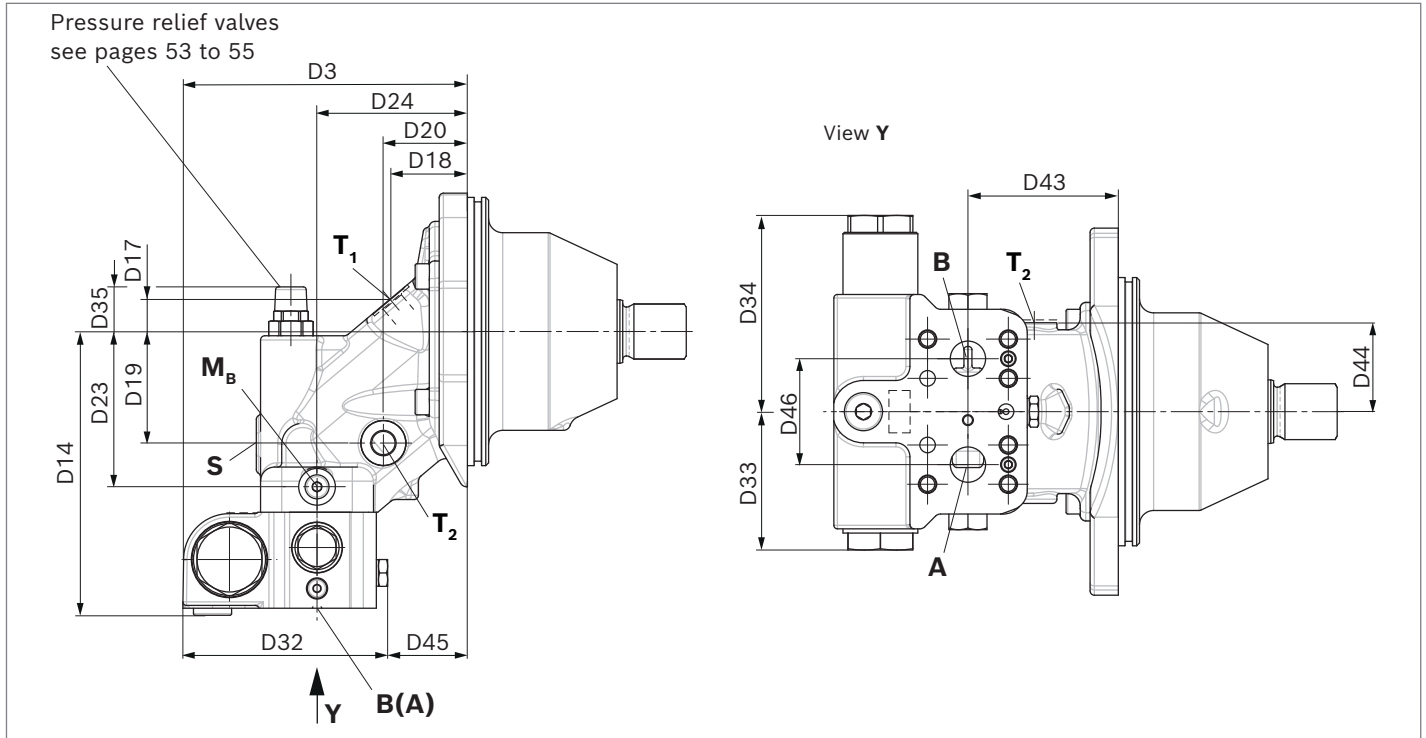

Size		D3	D14	D17	D18	D19	D20	D23	D24	D32	D33	D34	D35	D43	D44	D45	D46
45, 56, 63	BVD20..17	205	193	22	54	70	53	105	103	140.5	98	139	32.5	103	55.5	57.5	75
80, 90	BVD20..27	226.5	201	21.3	53.5	79	59.5	110	106.5	140.5	98	139	31.5	106.5	63	61	75
107, 125	BVD20..28	213	203	21	65	98	110	47.5	118.5	140.5	98	139	32	118.5	74	74	84
	BVD25..38	225	220	21	65	98	110	47.5	118.5	158	120.5	175	32	118.5	74	67	84
	BVE25..38	225	221	21	65	98	110	47.5	118.5	167	137	214	32	118.5	85	67	84

Size		A, B	S	Br, G _{ext}	M _A , M _B	P _{St}	T ₁ , T ₂
45, 56, 63	BVD20..17	3/4 in	M22 × 1.5; 14 deep	M12 × 1.5; 12.5 deep	M12 × 1.5; 12 deep	G 1/4	M18 × 1.5; 12 deep
80, 90	BVD20..27	1 in	M22 × 1.5; 14 deep	M12 × 1.5; 12.5 deep	M12 × 1.5; 12 deep	G 1/4	M18 × 1.5; 12 deep
107, 125	BVD20..28	1 in	M22 × 1.5; 14 deep	M12 × 1.5; 12.5 deep	M12 × 1.5; 12 deep	G 1/4	M18 × 1.5; 12 deep
	BVD25..38	1 1/4 in	M27 × 2; 16 deep	M12 × 1.5; 12.5 deep	M12 × 1.5; 12 deep	G 1/4	M18 × 1.5; 12 deep
	BVE25..38	1 1/4 in	M27 × 2; 16 deep	M12 × 1.5; 12.5 deep	M12 × 1.5; 12 deep	G 1/4	M18 × 1.5; 12 deep

Ports	Version	Standard	Size	p _{max} [bar] ¹⁾	State ³⁾
A, B	Working port		SAE J518	See table above	O
S	Boost port		DIN 3852 ²⁾	See table above	X
Br	Brake release port, reduced high pressure	L	DIN 3852 ²⁾	See table above	O
G_{ext}	Brake release port, high pressure	S	DIN 3852 ²⁾	See table above	X
M_A, M_B	Measuring port pressure A/B		DIN 3852 ²⁾	See table above	X
T₁, T₂	Drain port		DIN 3852 ²⁾	See table above	X, O ⁴⁾

Mounting the counterbalance valve

When delivered, the counterbalance valve is fastened to the motor with two tacking screws (transport lock). The tacking screws may not be removed while mounting the working lines. If the counterbalance valve and motor are delivered

separately, the counterbalance valve must first be fastened to the motor port plate using the provided tacking screws. The counterbalance valve is finally mounted to the motor by fitting the SAE flange. The screws to be used and the instructions for mounting can be found in the instruction manual.

1) Depending on the application, momentary pressure peaks can occur. Keep this in mind when selecting measuring devices and fittings.
2) The countersink may be deeper than specified in the standard.

3) O = Must be connected (plugged on delivery)
X = Plugged (in normal operation)
4) Depending on installation position, T₁ or T₂ must be connected (see also installation instructions on page 62).

Port plate with integrated check valve (U)

Function

The motor with defined direction of rotation is supplied via the inlet port (**A** or **B**). As soon as the inlet is disabled and the driven component (e.g. fan wheel) is running due to its own flywheel mass, the motor operates as pump. Since the turning motor is no longer supplied by the inlet, it will get the required hydraulic fluid via the check valve from the return line.

▼ Circuit diagram

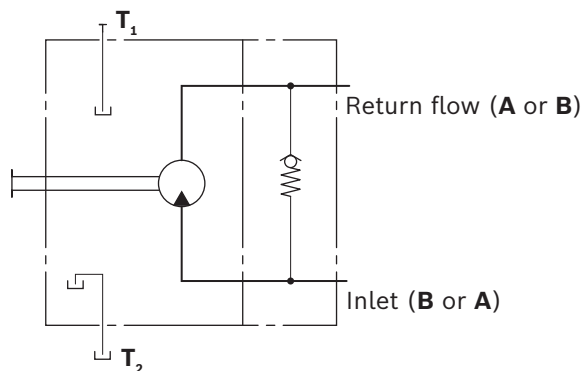

Flow direction

Direction of rotation, viewed on drive shaft	
clockwise	counter-clockwise
A to B	B to A

Speed sensor

The motor speed can be recorded by the fitted DSA speed sensor. The frequency signal required is generated by splines at the rotary group.

In addition to the rotational speed, the DSA sensor will record the direction of rotation of the motor.

Type code, technical data, dimensions and details on the plug, plus safety instructions about the sensor can be found in the relevant data sheet DSA (95133).

The sensor is mounted on the port provided for this purpose with a mounting bolt. On deliveries without sensor, the port is plugged with a pressure-resistant cover. We recommend ordering the A2F fixed motor complete with mounted sensor.

The following versions are available:

- ▶ with mounted DSA speed sensor: Code B
- ▶ prepared for DSA speed sensor (delivery without sensor): Code A

Size						
A2F.N	28, 32, 37, 45	56, 63, 80	90, 107	-	-	
A2F.M	23, 28, 32	45, 56, 63	80, 90	107, 125	160, 180	
A2F.H	23, 28, 32	45, 56, 63	80, 90	107, 125	-	
Number of teeth	38	47	53	59	67	
Dimensions						
A	90.9	96.6	108.4	113.6	124.5	
B	44.5	54.6	58.8	62.2	69.0	
C	27.1	36.3	30.4	31.1	41.7	

Dimensions

▼ A2FM with mounted DSA speed sensor (Code B)

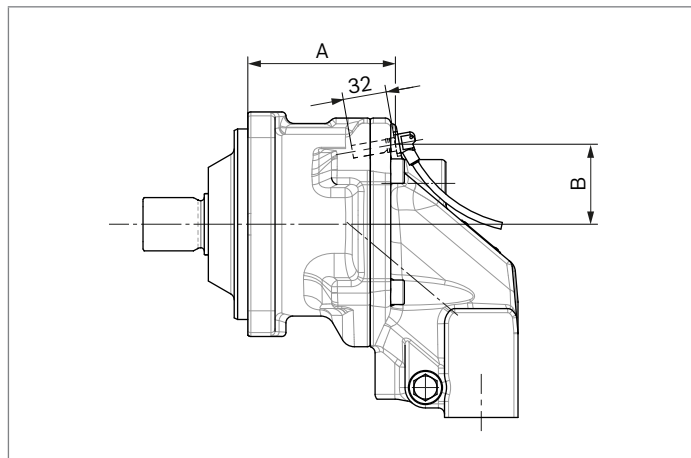

▼ A2FE with mounted DSA speed sensor (Code B)

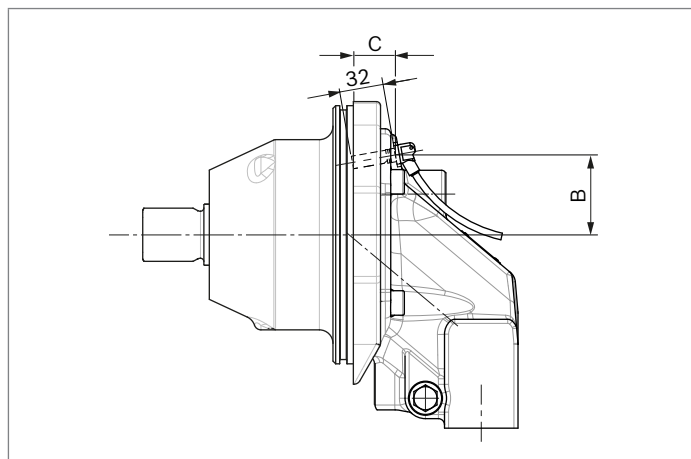

Installation instructions

General

The axial piston unit must be filled with hydraulic fluid and air bled during commissioning and operation. This must also be observed following a longer standstill as the axial piston unit may empty via the hydraulic lines.

Particularly in the installation position "drive shaft upwards", filling and air bleeding must be carried out completely as there is, for example, a danger of dry running.

The leakage in the housing area must be directed to the reservoir via the highest drain port (**T₁**, **T₂**).

If a shared drain line is used for several units, make sure that the respective case pressure in each unit is not exceeded. The shared drain line must be dimensioned to ensure that the maximum permissible case pressure of all connected units is not exceeded in any operating conditions, particularly at cold start. If this is not possible, separate drain line must be laid, if necessary.

To prevent the transmission of structure-borne noise, use elastic elements to decouple all connecting lines from all vibration-capable components (e.g. reservoir, frame parts). Under all operating conditions, the drain line must flow into the reservoir below the minimum fluid level.

Notice

- ▶ For A2FM with installation position "shaft upwards" an air bleed port **R** is required (specify in plain text when ordering, special version).
- ▶ For A2FE the "shaft upwards" installation position is not permissible.

Key	
F	Filling / air bleeding
R	Air bleed port (special version)
T₁, T₂	Drain port
h_{t min}	Minimum required immersion depth (200 mm)
h_{min}	Minimum required distance to reservoir bottom (100 mm)

Installation position

See the following examples **1** to **8**.

Further installation positions are available upon request.
Recommended installation position: **1** and **2**

Below-reservoir installation (standard)

Below-reservoir installation means that the axial piston unit is installed outside of the reservoir below the minimum fluid level.

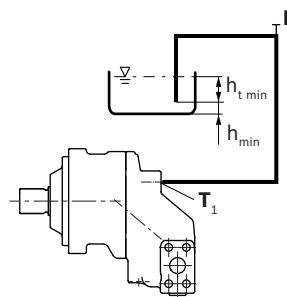
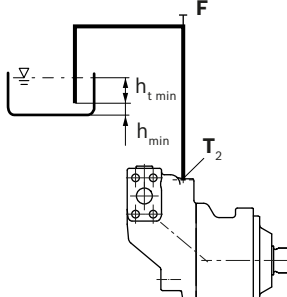
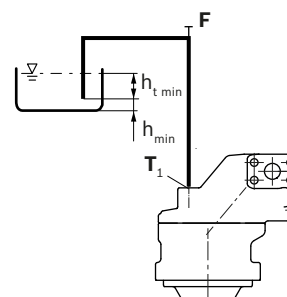
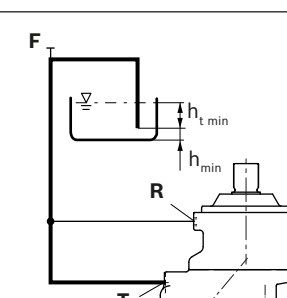
Installation position	Air bleed	Filling
<p>1</p> 	F	T₁
<p>2</p> 	F	T₂
<p>3</p> 	F	T₁
<p>4</p> 	R	T₂

Above-reservoir installation

Above-reservoir installation means that the axial piston unit is installed above the minimum fluid level of the reservoir. Recommendation for installation position **8** (drive shaft up): A check valve in the drain line (cracking pressure 0.5 bar) can prevent draining of the housing area.

Notice
 Port **F** is part of the external piping and must be provided on the customer side to simplify the filling and air bleeding.

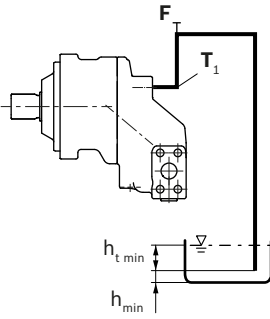
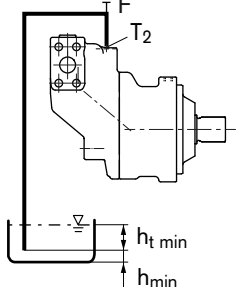
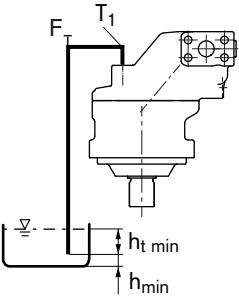
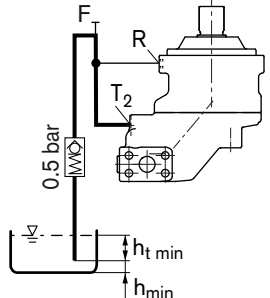
Installation position	Air bleed	Filling
<p>5</p> 	F	T₁ (F)
<p>6</p> 	F	T₂ (F)
<p>7</p> 	F	T₁ (F)
<p>8</p> 	R	T₂ (F)

Project planning notes

- ▶ The motor A2FM/A2FE is designed to be used in open and closed circuits.
- ▶ Project planning, installation and commissioning of the axial piston units requires the involvement of skilled personnel.
- ▶ Before using the axial piston unit, please read the corresponding instruction manual completely and thoroughly. If necessary, this can be requested from Bosch Rexroth.
- ▶ Before finalizing your design, request a binding installation drawing.
- ▶ The specified data and notices contained herein must be observed.
- ▶ Preservation: Our axial piston units are supplied as standard with preservation protection for a maximum of 12 months. If longer preservation protection is required (maximum 24 months), please specify this in plain text when placing your order. The preservation periods apply for optimal storage conditions, which can be found in data sheet 90312 or in the instruction manual.
- ▶ Not all versions of the product are approved for use in a safety function according to ISO 13849. Please consult the responsible contact person at Bosch Rexroth if you require reliability parameters (e.g. $MTTF_D$) for functional safety.
- ▶ Be sure to add a pressure relief valve to the hydraulic system.
- ▶ Please note that a hydraulic system is an oscillating system. This can lead, for example, to the excitation of the natural frequency within the hydraulic system during operation at constant rotational speed over a long period of time. The frequency of the motor to be observed is 7 times the rotational speed frequency. This can be prevented, for example, with suitably designed hydraulic lines.
- ▶ Please note the details regarding the tightening torques of port threads and other threaded joints in the instruction manual.

- ▶ The ports and fastening threads are designed for the p_{max} permissible pressures of the respective ports, see the port tables. The machine or system manufacturer must ensure that the connecting elements and lines correspond to the specified application conditions (pressure, flow, hydraulic fluid, temperature) with the necessary safety factors.
- ▶ The working ports and function ports are only intended to accommodate hydraulic lines.

Safety instructions

- ▶ During and shortly after operation, there is a risk of getting burnt on the axial piston unit. Take the appropriate safety measures (e.g. by wearing protective clothing).
- ▶ Moving parts in control equipment (e.g. valve spools) can, under certain circumstances, get stuck in position as a result of contamination (e.g. contaminated hydraulic fluid, abrasion, or residual dirt from components). As a result, the hydraulic fluid flow and the build-up of torque in the axial piston unit can no longer respond correctly to the operator's specifications. Even the use of various filter elements (external or internal flow filtration) will not rule out a fault but merely reduce the risk. The machine/system manufacturer must test whether remedial measures are needed on the machine for the application concerned in order to bring the driven consumer into a safe position (e.g. safe stop) and ensure any measures are properly implemented.
- ▶ In certain conditions, moving parts in high pressure relief valves might get stuck in an undefined position due to contamination (e.g. contaminated hydraulic fluid). This can result in restriction or loss of load-holding functions in lifting winches. The machine/system manufacturer must check whether additional measures are required on the machine for the relevant application in order to keep the load in a safe position and ensure they are properly implemented.

Bosch Rexroth AG

Glockeraustraße 2
89275 Elchingen
Germany
Tel. +49 7308 82-0
info.ma@boschrexroth.de
www.boschrexroth.com

© Bosch Rexroth AG 2021. All rights reserved, also regarding any disposal, exploitation, reproduction, editing, distribution, as well as in the event of applications for industrial property rights. The data specified within only serves to describe the product. No statements concerning a certain condition or suitability for a certain application can be derived from our information. The information given does not release the user from the obligation of own judgment and verification. It must be remembered that our products are subject to a natural process of wear and aging.