

Data Sheet

H1 Axial Piston Single Pump

Size 069/078 cm³



For more than 40 years, Danfoss has been developing state-of-the-art components and systems for mobile machinery used in off-highway operations around the world.

We have become a preferred supplier by offering the best of what really matters: The hardware inside your vehicle application.

The H1 range is built around an advanced control and available in a wide range of displacements. It is designed for quality and reliability and offers expanded functionality, greater total efficiency, and easy installation.

All H1 control and sensor options are PLUS+1[®] Compliant. PLUS+1[®] allows you to rapidly develop and customize electronic machine control. It opens up the future by combining machine controls and diagnostics in an integrated operating network.

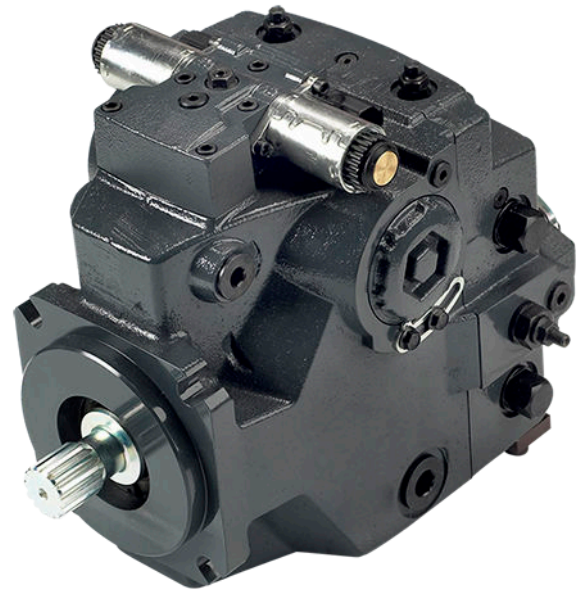

Features

Designed for quality and reliability

- One design concept
- Single piece swash plate

Installation and packaging benefits

- Length optimized pump
- Minimum one clean side
- Higher corner HP / package size ratio
- Standardized connector interface
- Expanded functionality through PLUS+1[®]

Wide range of controls

- Electro-hydraulic controls:
 - Electrical Displacement Control (EDC)
 - Forward-Neutral-Reverse (FNR)
 - Non-Feedback Proportional Electric (NFPE)
- Automotive Control (AC)
- Fan Drive Control (FDC)
- Manual Displacement Control (MDC)
- Common control across entire family

Expanded functionality

- PLUS+1[®] Compliant control and sensor options
- Integral filtration available with integrated filter bypass sensors and switch

Greater total efficiency

- Minimized control losses
- Improved charge circuit
- Lower control pressure for less power consumption

Comprehensive technical literature online at powersolutions.danfoss.com

Technical Specifications

Parameters		Size 069	Size 078
Displacement cm ³ [in ³]		69.2 [4.22]	78.1 [4.77]
Input speed min ⁻¹ (rpm)	Minimum	500	
	Rated	3500	
	Maximum	4000	
System pressure bar [psi]	Max. working*	450 [6525]	
	Maximum	480 [6962]	
	Min. low loop	10 [150]	
Case pressure bar [psi]	Rated	3.0 [40]	
	Maximum	5.0 [75]	
Weight (without PTO and filter), kg [lb]		56 [123]	

* Pressures above max. working pressure requires Danfoss approval.

Schematic

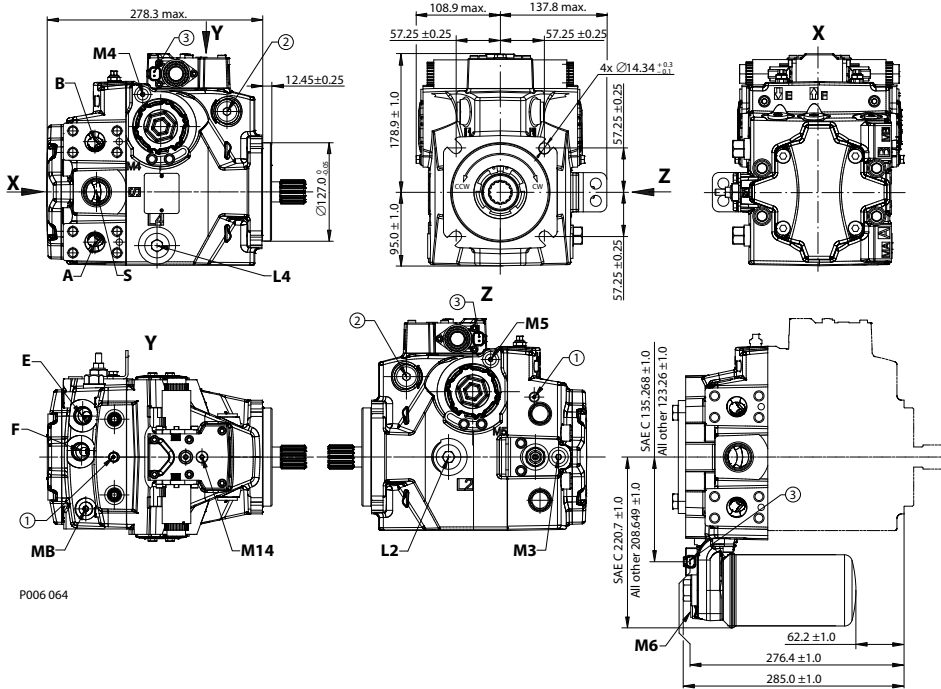
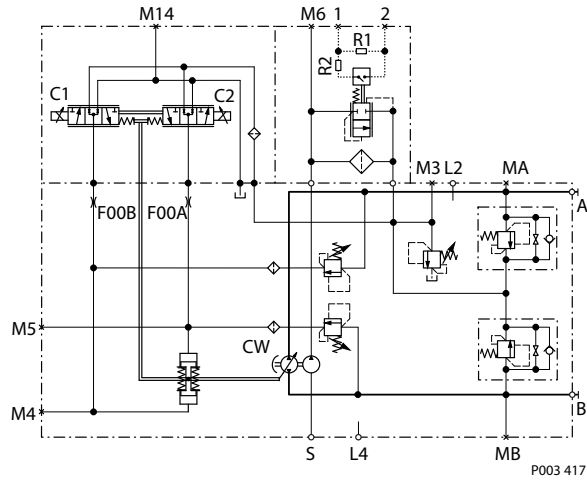

- A, B** – System ports, Ø25.4 – 450 bar Split flange boss per ISO 6162
 - MA, MB** – System gauge ports, 9/16-18; Ø28
 - M3, M6** – Charge gauge port, 9/16-18; Ø24.5
 - M4, M5** – Servo gauge ports, 7/16-20; Ø24.5
 - M14** – Case gauge port, 7/16-20; except spot face depth: 5 max. Ø15
- Ports per ISO 11926-1; max. clearance dia for fitting.

- L2, L4** – Case drain ports, 1 1/16-12; Ø41
- E, F** – Charge filtration ports, 7/8-14; Ø42
- S** – Charge inlet port, 1 5/16-12; Ø63.0
- 1** – Charge pressure port, 5/16-24
- 2** – Case pressure port 7/8-14; Ø42.0
- 3** – Connector DEUTSCH

Detailed technical information are available in the *Technical Information Axial Piston Single Pumps, Size 069/078, BC0000058*.

Danfoss can accept no responsibility for possible errors in catalogues, brochures and other printed material. Danfoss reserves the right to alter its products without notice. This also applies to products already on order provided that such alterations can be made without changes being necessary in specifications already agreed. All trademarks in this material are property of the respective companies. Danfoss and the Danfoss logotype are trademarks of Danfoss A/S. All rights reserved.