

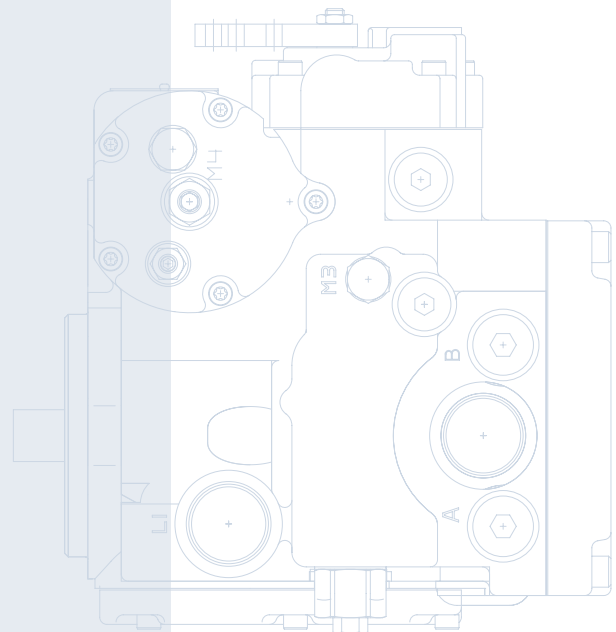

# Series 42 Axial Piston Pumps

## Technical Information

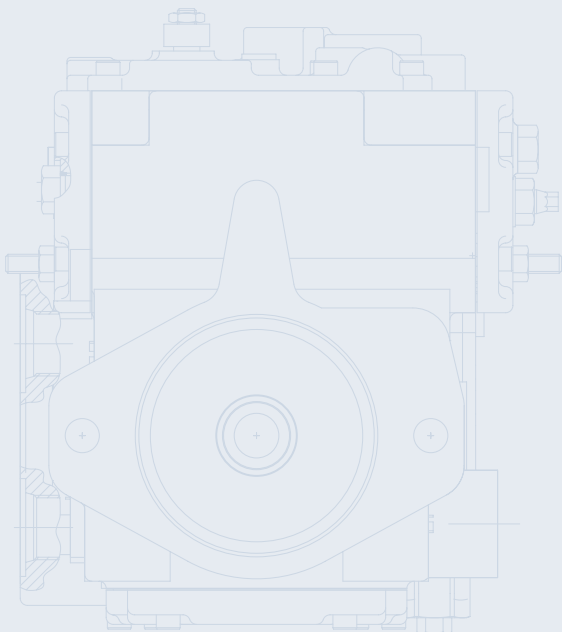
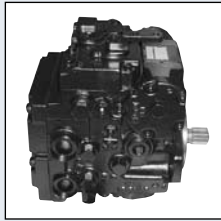
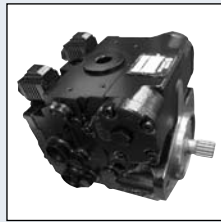

**HISTORY OF REVISIONS**

*Table of Revisions*

Date	Page	Changed	Rev.
October 2009	59	Connector/Spool:6=MS, high gain spool	CC
October 2009	8, 11	Table of Case Pressure, Pressure limits.Text of System Parameters-Case Pressure.	CB
September 2009	4-6, 8, 9, 25, 30-35, 40-43, 46, 53, 54, 56-58, 60, 64	Added HC-EDC and Frame Size 32. Corrections of text and drawings.	CA
January 2009	6-9, 17, 23-25, 31, 32, 34, 36-40, 43-47, 49-52, 54-61	Corrections of text and drawings.	BA
July 2007	16	Corrections to table -G factors for Sample Applications	AC
May 2007	-	Correction to PDF	AB
May 2007	-	Updated from existing PageMaker file	AA

© 2009 Sauer-Danfoss. All rights reserved.

Sauer-Danfoss accepts no responsibility for possible errors in catalogs, brochures and other printed material. Sauer-Danfoss reserves the right to alter its products without prior notice. This also applies to products already ordered provided that such alterations aren't in conflict with agreed specifications. All trademarks in this material are properties of their respective owners. Sauer-Danfoss and the Sauer-Danfoss logotype are trademarks of the Sauer-Danfoss Group.

Front cover illustrations: F301546, F301547, F301548, P100500E

<b>GENERAL DESCRIPTION</b>	Basic design.....	6
	System diagram .....	7
	Pump circuit .....	7
<b>TECHNICAL SPECIFICATIONS</b>	System specifications.....	8
	System parameters .....	8
	Hydraulic fluid parameters.....	9
<b>OPERATING PARAMETERS</b>	System requirements .....	10
	Independent braking system .....	10
	Reservoir .....	10
	System parameters .....	10
	Speed limits .....	10
	Inlet pressure.....	10
	Theoretical output.....	10
	Case pressure .....	11
	System pressure .....	11
	Hydraulic fluid parameters.....	12
	Hydraulic fluid.....	12
	Temperature and viscosity .....	12
	<b>SYSTEM DESIGN PARAMETERS</b>	Sizing equations .....
Fluid and filtration.....		14
Filtration configuration .....		14
Suction filtration.....		14
Partial-flow Charge Pressure Filtration.....		14
Full-flow Charge Pressure Filtration .....		15
Mounting flange loads .....		16
Estimating overhung load moment.....		16
External shaft load and bearing life.....		17
Hydraulic unit life .....		18
Efficiency graphs .....		18

**FEATURES AND OPTIONS**

Charge pump.....	19
Charge relief valve.....	20
Charge pump sizing example: .....	20
Overpressure protection .....	21
Bypass valves .....	21
Displacement limiters.....	22
Loop flushing.....	22
Speed sensor.....	23
Connecting pin designation:.....	23
Shaft options.....	24
Auxiliary mounting pads .....	24
Control selection .....	25
Manual displacement control (MDC) .....	26
Features and benefits of MDC.....	26
Control input signal .....	27
Response time .....	27
Control handles .....	28
Electric solenoid override to neutral.....	28
Emergency override to neutral with port for brake pressure release .....	28
Neutral Start Switch (NSS) .....	29
NSS with Back-Up Alarm (BUA) switch .....	29
Connectors.....	29
Electrical displacement control (HC-EDC) .....	30
Features and benefits of HC-EDC .....	31
Response time .....	31
Control input signal .....	32
Connectors and port locations .....	32
Control signal requirements.....	32
Electrical displacement control (EDC).....	33
Features and benefits of EDC.....	34
Response time .....	34
Control input signal .....	35
Connectors and port locations .....	35
Coil options.....	35
Non-feedback, proportional hydraulic (NFPH) control.....	36
Features and benefits of the NFPH control.....	36
Connectors and port locations.....	36

	Non-feedback, proportional electric (NFPE) control .....	37
	Features of the NFPE control .....	37
	Input signal requirements .....	37
	Connectors and port locations .....	37
	Forward, Neutral, Reverse, (FNR) control .....	38
	Features and benefits of FNR control .....	38
	Input signal requirements .....	38
	Connectors and port locations .....	38
<b>INSTALLATION</b>		
<b>DRAWINGS</b>		
	Frame size 28/32 .....	39
	Base unit with manual displacement control (MDC) .....	39
	Frame size 41/51 .....	41
	Base unit with manual displacement control (MDC) .....	41
	Shaft options .....	43
	Filtration options .....	44
	Suction filtration adapter - option G .....	44
	Charge pressure filtration adapter - full filter flow - option B .....	44
	No charge pump - option X .....	45
	Charge pressure filtration - full filter flow (no adapter) - option F .....	45
	Control modules .....	46
	Manual displacement control (MDC) options .....	46
	Electric control (FNR) options 28/32 cm <sup>3</sup> .....	48
	Three-position electric control (FNR) options 41/51 cm <sup>3</sup> .....	49
	Three-position electric control (FNR) options 41/51 cm <sup>3</sup> .....	50
	Non-feedback proportional hydraulic (NFPH) control options .....	51
	Non-feedback proportional electric (NFPE) control options 28/32 cm <sup>3</sup> .....	52
	Non-feedback proportional electric (NFPE) control options 41/51 cm <sup>3</sup> .....	52
	Electrical displacement control (HC-EDC) options .....	53
	Electrical displacement control (EDC) options .....	54
	Speed sensor option .....	55
	Auxiliary mounting pads .....	56
<b>SCHEMATICS</b>	Pump schematics .....	57
<b>MODEL CODE</b>	Pump model code .....	58

**BASIC DESIGN**

Series 42 pumps are advanced hydrostatic units for medium power applications with maximum loads of 415 bar [6017 psi] (28/41 cm<sup>3</sup>) and 350 bar [5075 psi] (32/51 cm<sup>3</sup>). You can combine these pumps with a suitable Sauer-Danfoss motor or other products in a system to transfer and control hydraulic power.

The Series 42 variable displacement pump is a compact, high power density unit, using the parallel axial piston/slipper concept in conjunction with a tiltable swashplate to vary the pump's displacement.

Reversing the angle of the swashplate reverses the flow of fluid from the pump, and reversing the direction of rotation of the motor output. Series 42 pumps provide an infinitely variable speed range between zero and maximum in both forward and reverse.

Series 42 pumps use a cradle swashplate design with a hydraulic servo control cylinder. Control is provided through a compact servo control system. A variety of servo controls are available. These include mechanically- or electrically-actuated feedback controls, hydraulic or electric proportional controls, and a three-position electric control. These controls feature low hysteresis and responsive performance.

*28/32/41/51 cm<sup>3</sup> cross-sectional view*

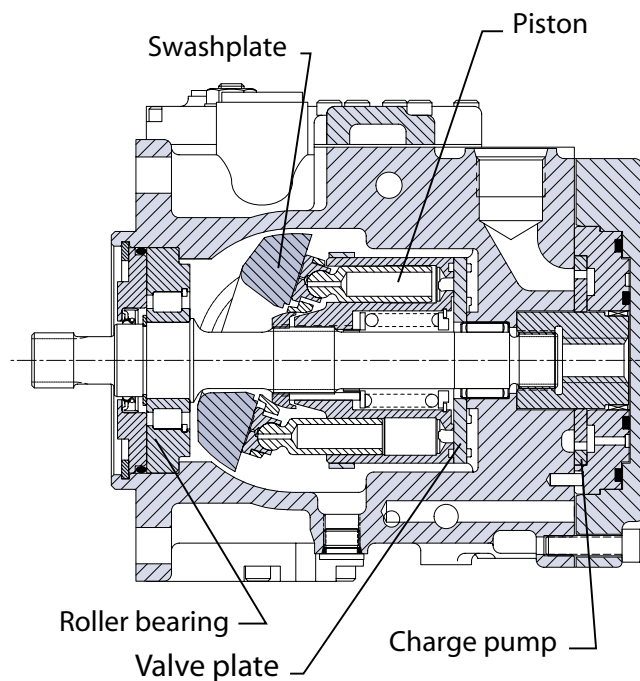

P100382E

**SYSTEM DIAGRAM**

*Pictorial circuit diagram*

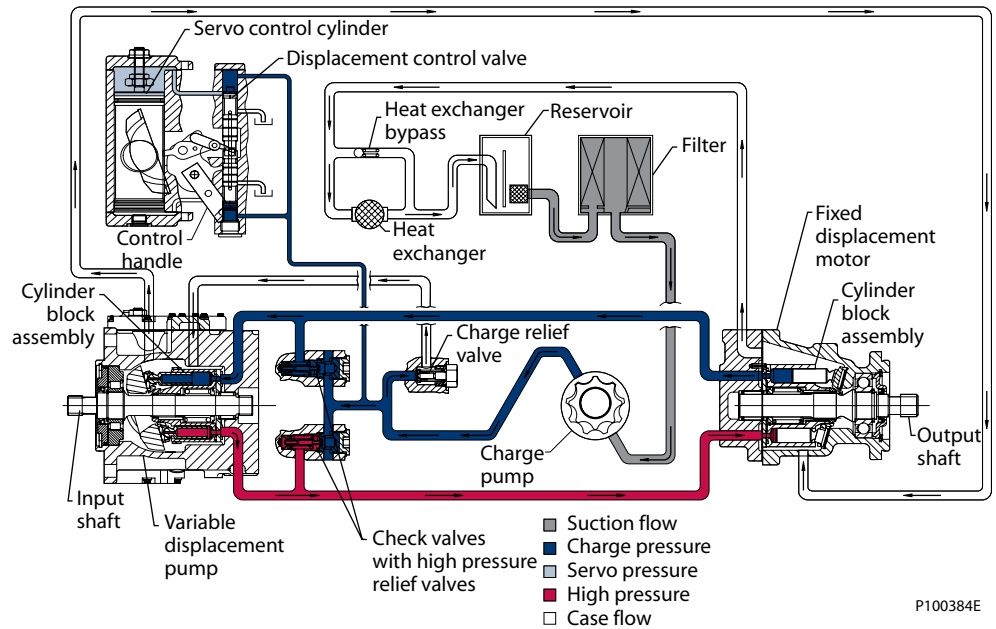

This illustration shows a Series 42 variable pump in a hydraulic circuit with a Series 40 - M35 fixed motor. The circuit is set up in a suction filtration configuration with a displacement control valve included on the pump. Note the position of the reservoir and heat exchanger.

**PUMP CIRCUIT**

*Schematic diagram*

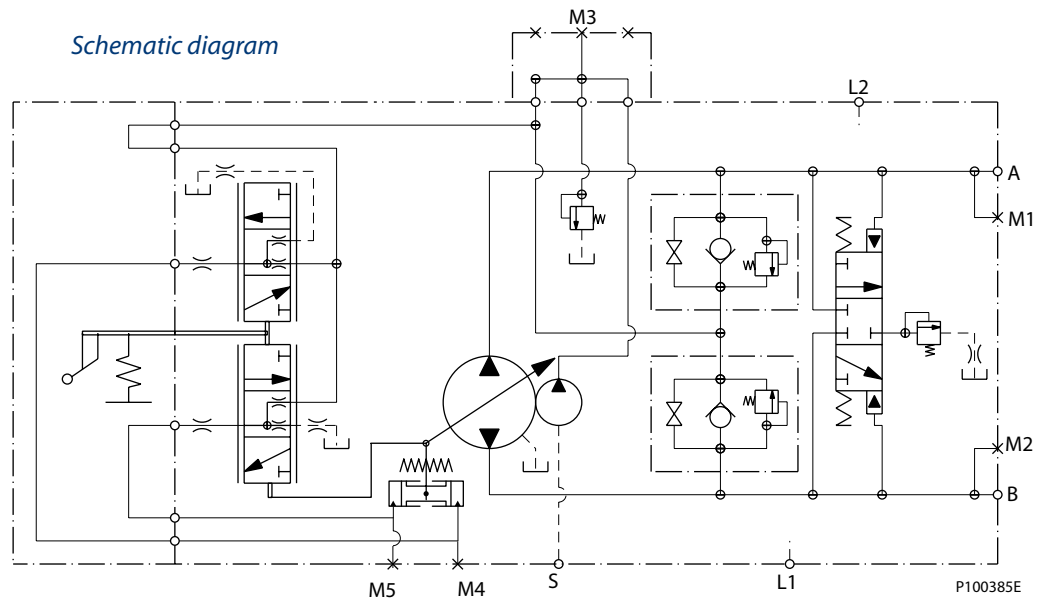

The illustration above shows a schematic of a Series 42 pump. System ports A and B connect to the high pressure work lines. Return fluid is received from its inlet port, pressurized, and discharged through the outlet port. Flow direction is determined by swashplate position. You can read system port pressure through ports M1 and M2. The pump has two case drains (L1 and L2) to ensure there is lubricating fluid in the system. This schematic includes a manual displacement control and loop flushing valve. For other control schematics see the related control section.

## SYSTEM SPECIFICATIONS

### General specifications

<b>Pump type</b>	In-line, axial piston, positive displacement pumps including cradle washplate and servo control
<b>Direction of input rotation</b>	Clockwise or counterclockwise
<b>Recommended installation position</b>	Pump installation recommended with control position on the top or side. Consult Sauer-Danfoss for non conformance guidelines. The housing must always be filled with hydraulic fluid.
<b>Filtration configuration</b>	Suction or charge pressure filtration
<b>Other system requirements</b>	Independent braking system, suitable reservoir and heat exchanger.

### Hardware features

<b>Pump configuration</b>	Single variable pump			
<b>Frame size cm<sup>3</sup></b>	<b>28</b>	<b>32</b>	<b>41</b>	<b>51</b>
<b>Displacement cm<sup>3</sup>[in<sup>3</sup>]</b>	28 [1.71]	31.8 [1.94]	40.9 [2.50]	51 [3.11]
<b>Weight kgf [lbf]</b>	34.5 [76]	34.5 [76]	42 [92]	42 [92]
<b>Mass moment of inertia kg·m<sup>2</sup> [lbf·ft<sup>2</sup>]</b>	0.0018 [0.0013]	0.0019 [0.0013]	0.0036 [0.0027]	0.0038 [0.0028]
<b>Type of front mounting flange (SAE flange size per SAE J744)</b>	SAE B			
<b>Port connections</b>	SAE-twin ports, radial			
<b>System pressure regulation bar [psi]</b>	140-415 [2030-6017]	140-345 [2030-5003]	140-415 [2030-6017]	140-345 [2030-5003]
<b>Displacement limiters</b>	Option			
<b>Input shaft options</b>	Splined, Round Straight Key, Tapered Shaft with Key			
<b>Auxiliary mounting pad (SAE pad per SAE J744)</b>	SAE A (9 tooth and 11 tooth) SAE B (13 tooth and 15 tooth)			
<b>Control options</b>	MDC, FNR, NFPH, NFPE, HC-EDC, EDC			
<b>Filtration configuration</b>	Suction or charge pressure filtration			
<b>Loop flushing</b>	Option			

## SYSTEM PARAMETERS

### Case pressure

<b>Rated pressure bar [psi]</b>	3 [44]
<b>Maximum pressure (cold start) bar [psi]</b>	5 [73]

### Pressure limits

<b>Frame size cm<sup>3</sup></b>	<b>28</b>	<b>32</b>	<b>41</b>	<b>51</b>
<b>Maximum working pressure* bar [psi]</b>	400 [5800]	350 [5075]	400 [5800]	350 [5075]
<b>Maximum pressure bar [psi]</b>	450 [6525]	400 [5800]	450 [6525]	400 [5800]

\* Operation above maximum working pressure is permissible with Sauer-Danfoss application approval.

### Inlet pressure

<b>Continuous pressure bar (absolute) [in Hg vacuum]</b>	0.8 [6]
<b>Minimum pressure (cold start) bar (absolute) [in Hg vacuum]</b>	0.2 [24]



**SYSTEM PARAMETERS**  
 (continued)

*Speed limits*

<b>Frame size cm<sup>3</sup></b>	<b>28</b>	<b>32</b>	<b>41</b>	<b>51</b>
<b>Minimum speed min<sup>-1</sup> (rpm)</b>	500	500	500	500
<b>Rated speed at maximum displacement min<sup>-1</sup> (rpm)</b>	3400	3000	3200	2900
<b>Maximum speed at maximum displacement min<sup>-1</sup> (rpm)</b>	3750	3400	3450	3400

*Charge pump displacement and setting pressure*

<b>Frame size cm<sup>3</sup></b>	<b>28/32</b>	<b>41/51</b>
<b>Charge pump</b>		
<b>Internal cm<sup>3</sup>/rev [in<sup>3</sup>/rev]</b>	<b>Standard</b>	
Internal	11 [.67]	15.6 [.92]
<b>External</b>	—	Optional
<b>Charge relief valve settings bar [psi]</b>	<b>Standard</b>	
Standard	14 [203]	20 [290]
<b>Optional</b>	10-24 [145-348]	10-24 [145-348]

*Theoretical flow*

<b>Frame size cm<sup>3</sup></b>	<b>28</b>	<b>32</b>	<b>41</b>	<b>51</b>
<b>Theoretical flow at rated speed l/min [US gal/min]</b>	95.2 [25.1]	95.4[25.2]	131 [34.6]	148 [39.1]

*Check / high pressure relief valve*

<b>Options</b>	No relief valve / check only	Relief valve / check
<b>Settings bar [psi]</b>	-	140-415 [2030-6017]

**HYDRAULIC FLUID PARAMETERS**

*Fluid temperature range*

Minimum	-40 °C [-40 °F]	Intermittent, cold start
Rated	104 °C [220 °F]	Maximum
Maximum	115 °C [240 °F]	Intermittent

*Fluid cleanliness level*

Required fluid cleanliness level	ISO 4406 Class 22/18/13
Recommended $\beta_{2-5}$ -ratio for suction filtration	$\beta_{2-5-45} = 75$ ( $\beta_{10} \geq 2$ )
Recommended $\beta_{2-5}$ -ratio for charge pressure filtration	$\beta_{15-20} = 75$ ( $\beta_{10} \geq 10$ )
Recommended inlet screen size for charge pressure filtration	100 $\mu\text{m}$ -125 $\mu\text{m}$

*Fluid viscosity*

Minimum	7 mm <sup>2</sup> /s (cSt) [47 SUS]	Intermittent
Recommended operating range	12-60 mm <sup>2</sup> /s (cSt) [66-278 SUS]	
Maximum	1600 mm <sup>2</sup> /s (cSt) [7500 SUS]	Intermittent, cold start

**SYSTEM REQUIREMENTS****Independent braking system****▲ Warning****Unintended vehicle or machine movement hazard.**

The loss of hydrostatic drive line power, in any mode of operation (forward, neutral, or reverse) may cause the system to lose hydrostatic braking capacity. You must provide a braking system, redundant to the hydrostatic transmission, sufficient to stop and hold the vehicle or machine in the event of hydrostatic drive power loss.

**Reservoir**

Design the system to accommodate maximum volume changes during all system operating modes and to promote de-aeration of the fluid as it passes through the tank.

Minimum reservoir volume is  $\frac{5}{8}$  of the maximum charge pump flow per minute with a minimum fluid volume equal to  $\frac{1}{2}$  of the maximum charge pump flow per minute. At the maximum return flow, this allows 30 seconds fluid dwell for removing entrained air. This is adequate for a closed reservoir (no breather) in most applications.

Position the reservoir outlet (pump inlet) above the bottom of the reservoir to take advantage of gravity separation and prevent large foreign particles from entering the charge inlet line. Use a 100 - 125  $\mu\text{m}$  screen over the outlet port.

Position the reservoir inlet (fluid return) so that flow to the reservoir is discharged below the normal fluid level, and directed into the interior of the reservoir for maximum dwell and efficient de-aeration. Use a baffle (or baffles) between the inlet and outlet ports to promote de-aeration and reduce surging of the fluid.

**SYSTEM PARAMETERS****Speed limits**

Rated speed is the speed limit we recommend at full power condition and is the highest value at which you can expect normal life.

Maximum speed is the highest operating speed we permit. You cannot operate above this speed without risk of immediate failure and loss of drive line power and hydrostatic braking capacity (which may create a hazard). In mobile applications, you must apply this pump with a speed below the stated maximum. Consult **BLN-9884, Pressure and Speed Limits**, when determining speed limits for a particular application.

**Inlet pressure**

Control charge pump inlet conditions to achieve expected life and performance. Ensure a continuous inlet pressure of not less than 0.8 bar absolute (not more than 6 in Hg vacuum). Normal pressures less than 0.7 bar absolute (greater than 9 in Hg vacuum) indicate inadequate inlet design or a restricted filter. Pressures less than 0.7 bar absolute (greater than 9 in Hg vac) during cold start are possible, but should improve quickly as the fluid warms. Never exceed the maximum inlet vacuum.

**Theoretical output**

The theoretical maximum flow at rated speed is a simple function of pump displacement and speed. This is a good gauge for sizing a companion motor. This does not take into account losses due to leakage or variations in displacement.

**SYSTEM PARAMETERS**  
(continued)

**Case pressure**

Under normal operating conditions, the **rated case pressure** must not be exceeded. During cold start case pressure must be kept below maximum intermittent case pressure. Size drain plumbing accordingly.

**System pressure**

**System pressure** is the differential pressure between high pressure system ports. It is the dominant operating variable affecting hydraulic unit life. High system pressure, which results from high load, reduces expected life. Hydraulic unit life depends on the speed and normal operating, or weighted average, pressure that can only be determined from a duty cycle analysis.

**Application pressure** - is the high pressure relief or pressure limiter setting normally defined within the order code of the pump. This is the applied system pressure at which the driveline generates the maximum calculated pull or torque in the application.

**Maximum Working Pressure** - is the highest recommended Application pressure. Maximum working pressure is not intended to be a continuous pressure. Propel systems with Application pressures at, or below, this pressure should yield satisfactory unit life given proper component sizing.

**Maximum pressure** is the highest allowable Application pressure under any circumstance. Application pressures above Maximum Working Pressure will only be considered with duty cycle analysis and factory approval.

**Minimum pressure** must be maintained under all operating conditions to avoid cavitation.

---

All pressure limits are differential pressures referenced to low loop (charge) pressure. Subtract low loop pressure from gauge readings to compute the differential.

---

**HYDRAULIC FLUID  
PARAMETERS****Hydraulic fluid**

Ratings and data are based on operating with hydraulic fluids containing inhibitors to prevent oxidation, rust, and foam. These fluids must possess good thermal and hydrolytic stability to prevent wear, erosion, and corrosion of the internal components. Fire resistant fluids are also suitable at modified operating conditions. Please see Sauer-Danfoss publication **520L0463**, *Hydraulic Fluids and Lubricants, Technical Information* for more information.

Do not mix different types of hydraulic fluids. Contact your Sauer-Danfoss representative for more information on fluid selection. The following hydraulic fluids are suitable:

- Hydraulic Oil ISO 11 158 - HM (Seal compatibility and vane pump wear resistance per DIN 51 524-2 must be met)
- Hydraulic Oil ISO 11 158 - HV (Seal compatibility and vane pump wear resistance per DIN 51 524-3 must be met)
- Hydraulic Oil DIN 51 524-2 - HLP • Hydraulic Oil DIN 51 524-3 - HVLP
- Automatic Transmission Fluid ATF A Suffix A (GM)
- Automatic Transmission Fluid Dexron II (GM), which meets Allison C-3 and Caterpillar TO-2 test
- Automatic Transmission Fluid M2C33F and G (Ford)
- Engine oils API Classification SL, SJ (for gasoline engines) and CI-4, CH-4, CG-4, CF-4 and CF (for diesel engines)
- Super Tractor Oil Universal (STOU) special agricultural tractor fluid

**Temperature and viscosity**

Ensure the application satisfies temperature and viscosity requirements concurrently. The data shown in the tables on page 9, *Hydraulic fluid parameters*, assume petroleum-based fluids.

High temperature limits apply at the hottest point in the transmission, which is normally the case drain. Always run the pump at or below the continuous temperature. Never exceed maximum temperature.

Durability of transmission components is not affected by cold oil, but it may affect the ability of oil to flow and transmit power. Keep temperatures 16 °C [30 °F] above the pour point of the hydraulic fluid. The minimum temperature relates to physical properties of component materials.

For maximum unit efficiency and bearing life, keep fluid viscosity in the continuous viscosity range. During brief occasions of maximum ambient temperature and severe duty cycle operation, minimum viscosity may occur. The system should encounter maximum viscosity only at cold start.

Size heat exchangers to keep the fluid temperature and viscosity within these limits. Test the system to verify that these temperature limits are not exceeded.

### SIZING EQUATIONS

Use these equations to help choose the right pump size and displacement for your application:

#### Based on SI units

*Flow* Output flow  $Q = \frac{V_g \cdot n \cdot \eta_v}{1000}$  (l/min)

*Torque* Input torque  $M = \frac{V_g \cdot \Delta p}{20 \cdot \pi \cdot \eta_m}$  (N·m)

*Power* Input power  $P = \frac{M \cdot n \cdot \pi}{30\,000} = \frac{Q \cdot \Delta p}{600 \cdot \eta_t}$  (kW)

#### Based on US units

Output flow  $Q = \frac{V_g \cdot n \cdot \eta_v}{231}$  (US gal/min)

Input torque  $M = \frac{V_g \cdot \Delta p}{2 \cdot \pi \cdot \eta_m}$  (lbf·in)

Input power  $P = \frac{M \cdot n \cdot \pi}{198\,000} = \frac{Q \cdot \Delta p}{1714 \cdot \eta_t}$  (hp)

#### Variables SI units [US units]

$V_g$	= Displacement per revolution	cm <sup>3</sup> /rev [in <sup>3</sup> /rev]
$p_o$	= Outlet pressure	bar [psi]
$p_i$	= Inlet pressure	bar [psi]
$\Delta p$	= $p_o - p_i$ (system pressure)	bar [psi]
$n$	= Speed	min <sup>-1</sup> (rpm)
$\eta_v$	= Volumetric efficiency	
$\eta_m$	= Mechanical efficiency	
$\eta_t$	= Overall efficiency ( $\eta_v \cdot \eta_m$ )	

**FLUID AND FILTRATION**

To prevent premature wear, use only new clean fluid. Use a filter capable of controlling fluid cleanliness to ISO 4406 Class 22/18/13 (SAE J1165).

Locate the filter on the inlet (suction filtration) or discharge (charge pressure filtration) side of the charge pump: Series 42 pumps are available with provisions for either configuration *see next page*.

The selection of a filter depends on a number of factors including the contaminant ingress rate, the generation of contaminants in the system, the required fluid cleanliness, and the desired maintenance interval. Use filters that meet the above requirements of efficiency and capacity.

Filter efficiency may be expressed in a Beta ratio ( $\beta$ ). For simple suction-filtered closed circuit transmissions, and open circuit transmissions with return line filtration, use a filter with a  $\beta$ -ratio in the range of  $\beta_{35-45} = 75$  ( $\beta_{10} \geq 2$ ) or better. For some open and closed circuit systems that supply cylinders from the same reservoir, a considerably higher filter efficiency is necessary. This also applies to systems with gears or clutches using a common reservoir. For these systems, use a filter within the range of  $\beta_{15-20} = 75$  ( $\beta_{10} \geq 10$ ) or better.

Because each system is unique, only a thorough testing and evaluation program can fully validate the filtration system. Please see *Design Guidelines for Hydraulic Fluid Cleanliness Technical Information, 520L0467* for more information.

**FILTRATION CONFIGURATION**

**Suction filtration**

The suction filter is in the circuit between the reservoir and the inlet to the charge pump as shown. All flow to the charge pump is filtered

**Caution**

**Clogged filters can reduce the flow of charge fluid to the pump. Replace filters regularly before they become blocked.**

*Suction filtration*

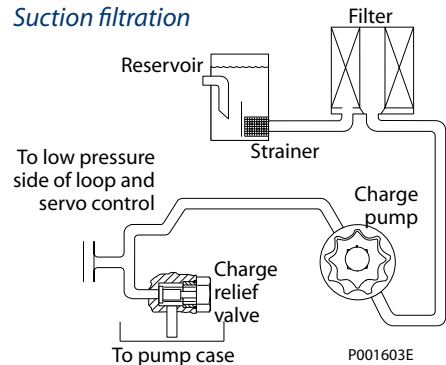

**Partial-flow Charge Pressure Filtration**

Charge pressure filtration is available on all Series 42 pumps. The pressure filter is remotely mounted and fits in the circuit after the charge pump, as shown. Charge pressure filtration can reduce inlet vacuum in cold start-ups and provides fluid filtration immediately upstream of the system loop and the control system.

In charge pressure filtration circuits, use non-bypass filters rated to at least 35 bar [508 psi] working pressure. Use a 100-125  $\mu$ m screen located in the reservoir or in the charge inlet line when using charge pressure filtration.

*Charge pressure filtration, partial flow*

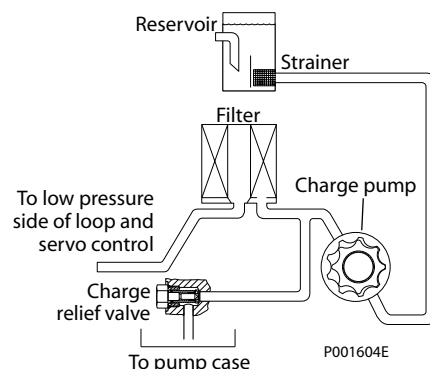

**FILTRATION  
 CONFIGURATION  
 (continued)**

Incorporating the charge pressure relief valve ahead of the filter element achieves partial filter flow. Filter flow is just enough to satisfy the needs of the system loop and control. Insufficient flow through the filter results in inadequate charge pressure and affects machine performance. Select a filter capable of withstanding a pressure drop equal to charge pressure while maintaining the filter  $\beta_x$ -ratio at or above a value of one (no additional contaminants introduced into system).

**Full-flow Charge Pressure Filtration**

Incorporating the charge pressure relief valve behind the filter element achieves full filter flow. Total charge flow passes through the filter increasing the rate of contaminant removal from the system.

A filter bypass valve is necessary to prevent filter damage and to avoid contaminants from forcing through the filter media due to high pressure differentials across a clogged filter. In the event of high pressure drop associated with a blocked filter or cold start-up conditions, fluid can bypass the filter. Avoid working with an open bypass for extended periods. Use a visual or electrical dirt indicator. Proper filter maintenance is mandatory.

*Charge pressure filtration, full flow*

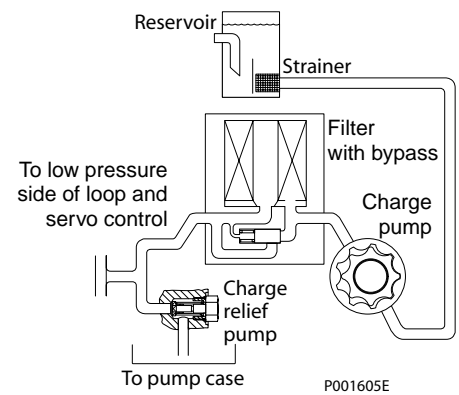

**MOUNTING FLANGE LOADS**

Adding tandem mounted auxiliary pumps and/or subjecting pumps to high shock loads may result in excessive loading of the mounting flange. Design pump applications to stay within the allowable shock load and continuous load moments.

Shock load moment  $M_s$  is the result of an instantaneous jolt to the system. Rated (continuous) load moments  $M_r$  are generated by the typical vibratory movement of the application.

Estimated maximum and continuous acceleration factors for some typical applications are shown in the table.

Applications which experience extreme resonant vibrations may require additional pump support. Exceeding the allowable overhung values listed below will require additional pump support.

*G-factors for sample applications*

Application	Continuous (vibratory) acceleration ( $G_R$ )	Maximum (shock) acceleration ( $G_S$ )
Skid steer loader	4	10
Trencher (rubber tires)	3	8
Asphalt paver	2	6
Windrower	2	5
Aerial lift	1.5	4
Turf care vehicle	1.5	4
Vibratory roller	6	10

*Allowable overhung load moments*

Frame size (cm <sup>3</sup> )	Rated load moment ( $M_r$ )	Shock load moment ( $M_s$ )
28/32	1441 N·m [12750 in·lbf]	3413 N·m [30200 in·lbf]
41/51	1441 N·m [12750 in·lbf]	3413 N·m [30200 in·lbf]

**Estimating overhung load moment**

$$M_r = G_R \cdot (W_1 L_1 + W_2 L_2 + \dots + W_n L_n)$$

$$M_s = G_S \cdot (W_1 L_1 + W_2 L_2 + \dots + W_n L_n)$$

- $M_r$  = Rated load moment N·m [lbf·in]
- $M_s$  = Shock load moment N·m [lbf·in]
- $G_R$  = Rated (vibratory) acceleration (G-factors: unitless)
- $G_S$  = Maximum shock acceleration (G-factors: unitless)
- $W$  = Weight of the pump N [lbf]
- $L$  = Distance from the mounting flange to the center of gravity mm [in]

*Overhung load moments*

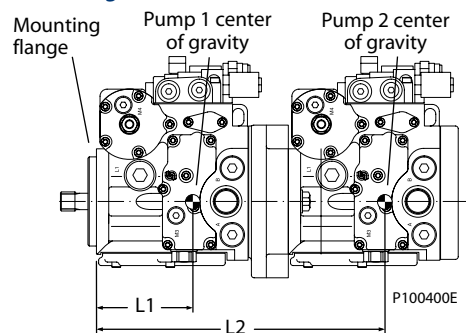

P100400E



**EXTERNAL SHAFT LOAD  
 AND BEARING LIFE**

Bearing life is a function of speed, pressure, and swashplate angle, plus any external loads. Other factors that affect life include fluid type, viscosity, and cleanliness.

In vehicle propulsion drives with no external loads—where the speed, pressure, and swashplate angle are often changing—normal bearing  $B_{10}$  (90% survival) life exceeds the hydraulic unit life.

In non-propel drives, such as conveyors or fan drives, the operating speed and pressure may be nearly constant leading to a distinctive duty cycle compared to that of a propulsion drive. In these types of applications, we recommend a bearing life review. Series 42 pumps use bearings that can accept some incidental external radial and thrust loads. However, any amount of external load reduces the expected bearing life.

The allowable radial shaft loads are a function of the load position, orientation, and operating pressures of the hydraulic unit. In applications where you cannot avoid external shaft loads, minimize the impact on bearing life by orienting the load to the 90° or 270° position.

The maximum allowable radial load is calculated as:  $R_e = M_e / L$   
 where:

- $L$  = Distance from mounting flange to point of load
- $M_e$  = Maximum external moment
- $R_e$  = Maximum radial side load
- $T_{out}$  = Thrust load

*Allowable shaft loads*

Frame size (cm <sup>3</sup> )	28	32	41	51
$M_e$	98	86	111	90
N•m [in•lbf]	[867]	[763]	[982]	[800]
$T_{out}$	1100	1100	1100	1100
N [lbf]	[250]	[250]	[250]	[250]

Avoid thrust loads in  $T_{in}$  direction.

If continuously applied external radial loads are 25% of the maximum allowable or more, or thrust loads are known to occur, contact your Sauer-Danfoss representative for an evaluation of unit bearing life.

Use tapered output shafts or clamp-type couplings where radial shaft side loads are present.

Use the table and drawing to determine maximum allowable radial loads ( $R_e$ ), based on the maximum external moment ( $M_e$ ) and the distance ( $L$ ) from the mounting flange to the load.

*External shaft load orientation*

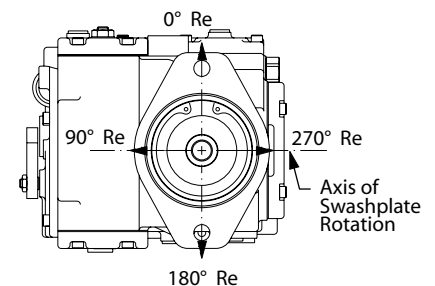
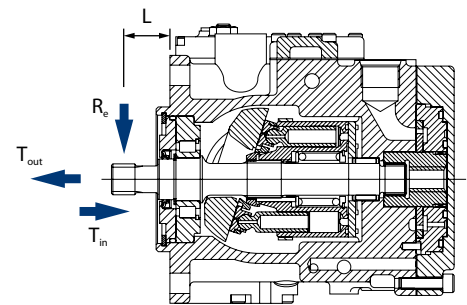

P100399E

**HYDRAULIC UNIT LIFE**

Hydraulic unit life is the life expectancy of the hydraulic components. Hydraulic unit life is a function of speed and system pressure. However, system pressure is the dominant operating variable. High pressure, which results from high load, reduces expected life.

Design the hydraulic system to a projected machine duty cycle. Know the expected percentages of time at various loads and speeds. Ask your Sauer-Danfoss representative to calculate an appropriate pressure based your hydraulic system design. If duty cycle data is not available, input power and pump displacement are used to calculate system pressure.

All pressure limits are differential pressures (referenced to charge pressure) and assume normal charge pressure.

Series 42 pumps will meet satisfactory life expectancy if applied within the parameters specified in this bulletin. For more detailed information on hydraulic unit life see BLN-9884, *Pressure and Speed Limits*.

**EFFICIENCY GRAPHS**

The performance graph below left provides typical volumetric and overall efficiencies for Series 42 pumps. These efficiencies apply for all Series 42 pumps at maximum displacement.

The performance map below right provides typical pump overall efficiencies at various operating parameters. These efficiencies also apply for all Series 42 pumps at maximum displacement.

*Pump performance as a function of operating speed at maximum displacement\**

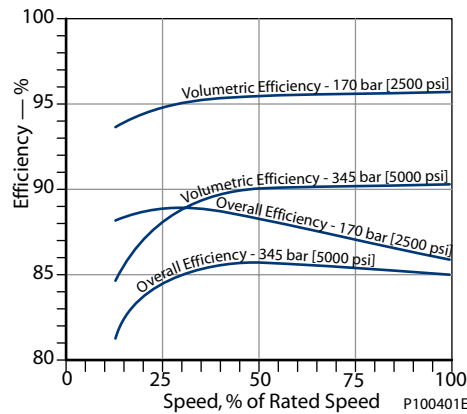

*Pump performance at select operating parameters at maximum displacement\**

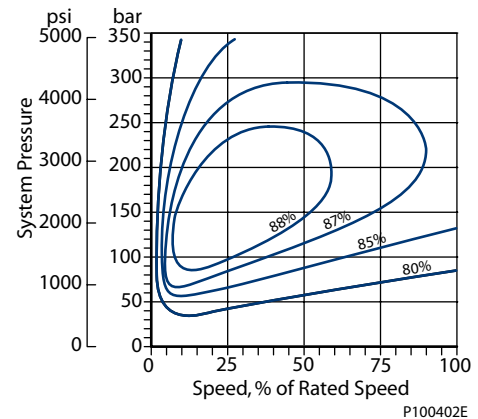

\* Assumes viscosity in the continuous range

**CHARGE PUMP**

All Series 42 pumps applied in closed circuit installations require charge flow to make up for internal leakage, to maintain positive pressure in the main circuit, to provide flow for cooling, to replace any leakage losses from external valving or auxiliary systems, and to provide flow and pressure for the pump control system.

Many factors influence the charge flow requirements and the resulting charge pump size selection. These factors include system pressure, pump speed, pump swashplate angle, type of fluid, temperature, size of heat exchanger, length and size of hydraulic lines, control response characteristics, auxiliary flow requirements, hydraulic motor type, etc.

*Gerotor Style Charge Pump*

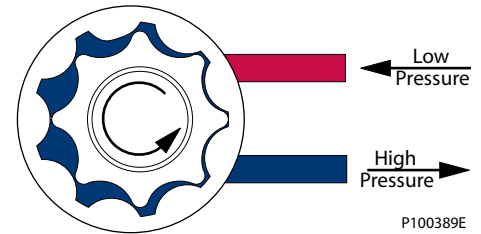

The total charge flow requirement is the sum of the charge flow requirements of each of the components in the system. When initially sizing and selecting hydrostatic units for an application, it is frequently not possible to have all of the information necessary to accurately evaluate all aspects of charge pump size selection. The following procedure will assist the designer in arriving at an initial charge pump selection for a typical application.

In most Series 42 applications a general guideline is that the charge pump displacement should be equal to or greater than 10% of the total displacement of all axial piston or bent-axis units in the system.

Series 42 pumps may be equipped with integral charge pumps. The available charge pump sizes should meet the needs of a majority of Series 42 applications.

Series 42 pumps are also available without charge pumps. When equipped without a charge pump, an external charge supply is required to ensure adequate charge pressure and cooling.

*Charge pump output flow*

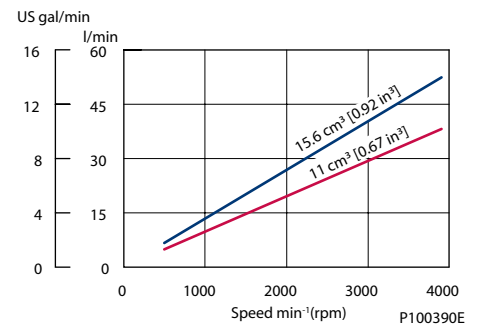

*Charge pump power requirements*

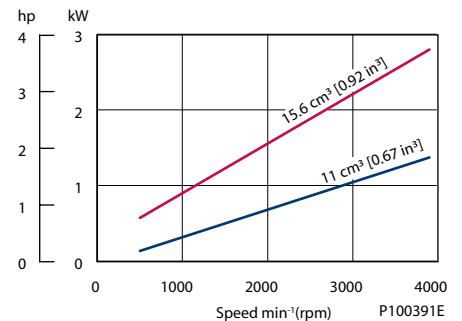

**CHARGE PUMP  
 (continued)**

Particular application conditions may require a more detailed review of charge pump sizing. System features and conditions that may invalidate the 10% of displacement rule include (but are not limited to):

- Operation at low input speeds (below 1500 rpm)
- Shock loading
- Excessively long system lines
- Auxiliary flow requirements
- Use of low speed, high torque motors

If a charge pump of sufficient capacity to meet the 10% of displacement rule is not available or if any of the above conditions exist, which could invalidate the 10% rule, contact your Sauer-Danfoss representative for application assistance.

You can find a charge pump sizing worksheet in *Selection of Driveline Components, BLN-9885*.

**Charge pump sizing example:**

A system consists of a single Series 42 - 28 Variable Pump driving two Series 40 -M35 Fixed Motors:

$$TD = 28 + 35 + 35 = 98 \text{ cm}^3$$

$$CPD = 10 \% \times TD = 9.8 \text{ cm}^3$$

This requires a charge pump displacement of 9.8 cm<sup>3</sup> [0.59 in<sup>3</sup>] or more. Sufficient charge flow for this application is provided by a 11 cm<sup>3</sup> [0.67 in<sup>3</sup>] charge pump.

**CHARGE RELIEF VALVE**

The charge relief valve maintains charge pressure at a designated level. Series 42 pumps come with direct-acting poppet style charge relief valves. The valve setting is set at the factory. The setting is screw adjustable.

The charge pressure settings are nominal values and are based on the charge flow across the charge relief valve with a fluid viscosity of 28 mm<sup>2</sup>/s (cSt) [130 SUS] and a pump input speed of 1800 min<sup>-1</sup>(rpm). Actual charge pressure differs slightly from the nominal setting when different input speeds are used. The charge setting is a differential pressure (referenced to case pressure) and measured with the piston pump at zero swashplate angle (neutral). Charge pressure drops slightly when the pump is in stroke due to flow demands.

The charge pressure setting for pumps without an internal charge pump is set with an assumed charge flow of 19 l/min (5 US gal/min). These units must have adequate charge flow supplied to the charge inlet in order to maintain charge pressure at all times.

**Caution**  
 Incorrect charge pressure settings may result in the inability to build required system pressure, inability to control pump, and/or inadequate loop flushing flows. Maintain correct charge pressure under all operating conditions.

Charge relief valve

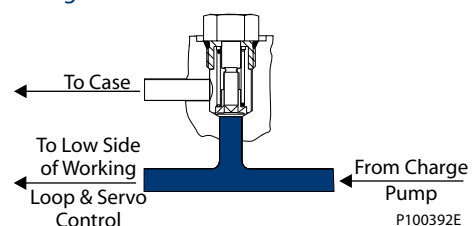

**OVERPRESSURE PROTECTION**

Series 42 pumps are available with a combination charge check and high pressure relief valve assembly. High pressure relief valves come in a range of settings as shown in the model code. You may specify individual port pressure settings. The high pressure relief valve settings are a differential pressure (referenced to charge pressure) and are set at 3.8 l/min (1 US gal/min) of flow.

*Charge check and high pressure relief valve*

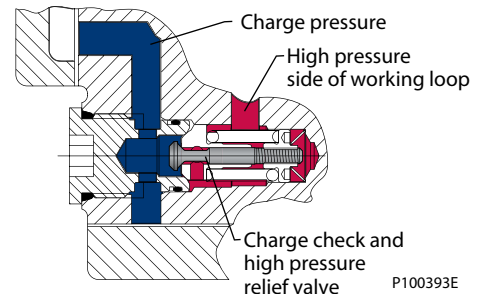

We can equip pumps with charge check valves only, if high pressure relief valve protection is not necessary.

**Caution**

High pressure relief valves are for transient overpressure protection, not for continuous pressure control. Operation over relief valves for extended periods of time results in severe heat build up. High flows over relief valves may result in pressure levels exceeding the nominal valve setting and potential damage to system components.

**BYPASS VALVES**

Series 42 pumps are available with an optional bypass function for use when pump shaft rotation is not possible. Use the bypass function to bypass fluid around the variable displacement pump. For example: you may move a disabled vehicle to a service location or winch it onto a trailer without operating the prime mover.

The bypass valve is integral to the charge check/high pressure relief valve assembly. Depress the plungers located in the plugs of the valve assemblies to operate the bypass function. The valves remain open until the prime mover is started. Charge pressure automatically closes them.

*Charge check and high pressure relief valve with bypass*

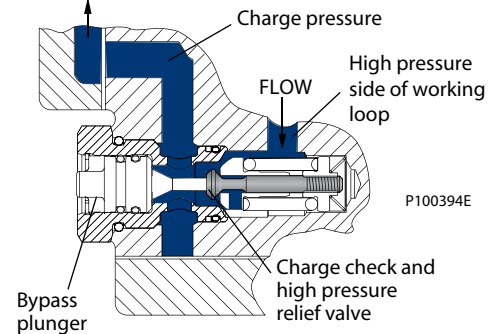

**Caution**

Damage to the hydraulic system may result from operating without charge flow. Bypass valves are for moving a machine or vehicle for very short distances at very slow speeds. They are NOT tow valves.

**DISPLACEMENT LIMITERS**

Series 42 pumps are available with adjustable mechanical displacement (stroke) limiters located in the servo covers. The maximum displacement of the pump can be limited to any value from its maximum displacement to zero in either direction. The limiters are factory set slightly beyond the maximum displacement of the pump. Displacement limiters may not be suited to all applications.

*Series 42 pump displacement limiters*

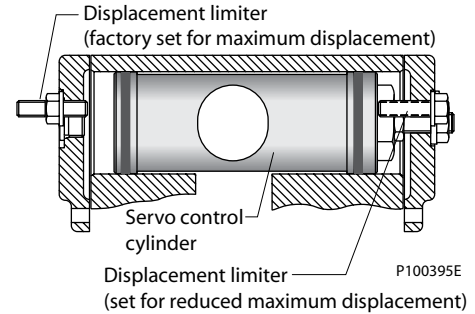

**LOOP FLUSHING**

Series 42 pumps have an integral loop flushing valve for circuits requiring the removal of excessive contamination or with high cooling requirements. We also provide an orificed loop flushing relief valve. The orifice controls loop flushing flow in most conditions. A combination of relief setting and orifice size controls flushing flow. For proper operation, ensure the loop flushing relief valve is set at or below the charge relief setting. Contact your Sauer-Danfoss representative for application assistance.

*Loop flushing valve*

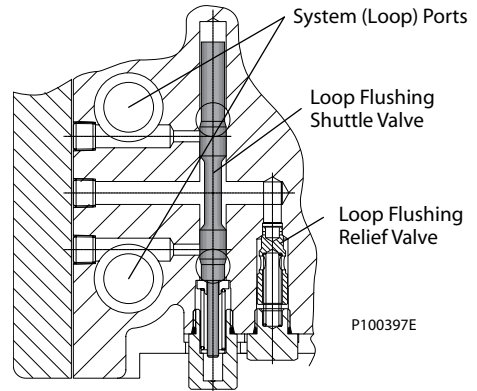

**CAUTION**  
 Incorrect pressure settings may result in the inability to build required system pressure, insufficient control pressure, and/or inadequate loop flushing flow. Maintain correct charge pressure under all operating conditions.

*Loop flushing flow*

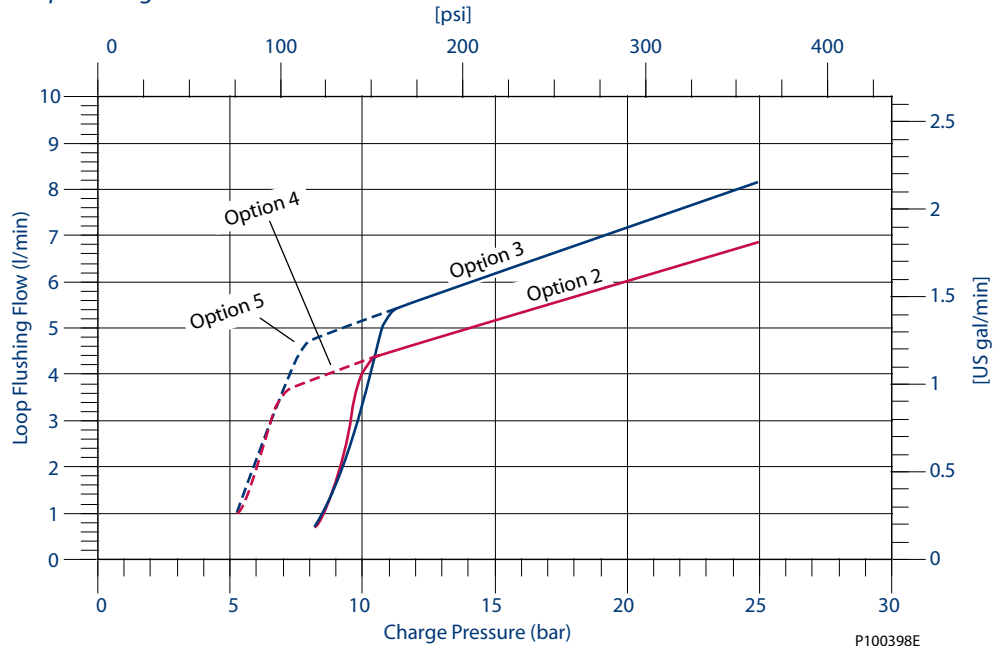

**SPEED SENSOR**

Series 42 pumps are available with a speed sensor option for direct measurement of pump input speed.

A special magnetic speed ring is pressed onto the outside diameter of the cylinder block and a Hall effect pulse pickup sensor is located in the pump housing. The sensor accepts supply voltage and outputs a digital pulse signal in response to the speed of the ring. The output changes its high/low state as the north and south poles of the permanently magnetized speed ring pass by the face of the sensor. The digital signal is generated at frequencies suitable for microprocessor based controls.

This sensor operates with a supply voltage of 4.5 to 15 Vdc, and requires a current of 12 mA at 5.0 Vdc under no load. Maximum operating current is 20 mA at 5 Vdc. Maximum operating frequency is 15 kHz. Output voltage in high state ( $V_{OH}$ ) is sensor supply voltage minus 0.5 Vdc, minimum. Output voltage in low state ( $V_{OL}$ ) is 0.5 Vdc, maximum.

Contact your Sauer-Danfoss representative for production availability on specific pump frame sizes, or for special speed sensor options.

**Connecting pin designation:**

- Pin A : Supply voltage
- Pin B : Speed signal, digital
- Pin C : Ground common
- Pin D : Direction of rotation

*Speed ring data*

Frame size (cm <sup>3</sup> )	28/32	41	51
Pulses/rev	41	47	47

*Technical data speed sensor*

<b>Supply voltage<sup>1)</sup></b>	4.5-8.5 Vdc
<b>Supply voltage regulated</b>	15 Vdc maximum
<b>Required current</b>	12 mA at 5 Vdc (no load)
<b>Maximum current</b>	20 mA at 5 Vdc and 1 Hz
<b>Maximum frequency</b>	15 kHz
<b>Voltage "high"</b>	Supply voltage -0.5 Vdc minimum
<b>Voltage "low"</b>	0.5 Vdc maximum
<b>Temperature range</b>	-40 to 110 °C [-40 to 230 °F]

<sup>1)</sup> It is not acceptable to energize the 4.5 - 8.5 Vdc speed sensor with 12 Vdc battery voltage; it must be energized by a regulated power supply. If it is desirable to energize the sensor with battery voltage, contact your Sauer-Danfoss representative for and optional speed sensor.

*Speed sensor with Packard Weather-Pack connector (KPPG13408)*

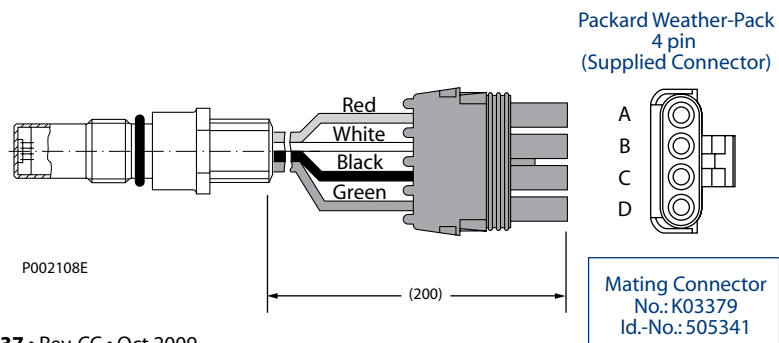

**SHAFT OPTIONS**

Series 42 pumps are available with a variety of splined and tapered shaft ends. The accompanying table shows available shaft sizes and torque ratings. Maximum torque ratings are based on shaft torsional strength and assume a maximum of 200 000 load reversals.

Use ANSI B92.1 Class 5 mating splines for splined output shafts. Sauer-Danfoss external splines are modified Class 5 fillet root side fit. The external spline major diameter and circular tooth thickness dimensions are reduced in order to insure a clearance fit with the mating spline.

*Shaft availability and torque rating\**

Shaft	Max. torque, 28/32 cm <sup>3</sup>	Max. torque, 41/51 cm <sup>3</sup>
13 tooth spline, 16/32 pitch	226 N•m [2000 in•lbf]	226 N•m [2000 in•lbf]
15 tooth spline, 16/32 pitch	362 N•m [3200 in•lbf]	362 N•m [3200 in•lbf]
19 tooth spline, 16/32 pitch	—	734 N•m [6500 in•lbf]
Tapered Ø25.4 mm [1 in] 1:8 taper	—	362 N•m [3200 in•lbf]**
Round Straight Key Ø25.4mm [1 in]	362 N•m [3200 in•lbf]	362 N•m [3200 in•lbf]**

\* The limitations of these input shafts constrain the allowable auxiliary coupling torque.

\*\* Not recommended for all options. Contact your Sauer-Danfoss representative.

**AUXILIARY MOUNTING PADS**

Auxiliary mounting pads are available on all Series 42 pumps to mount auxiliary hydraulic pumps. We include a sealed (oil tight) shipping cover as standard equipment. The shipping cover seals case pressure and you can use it as a running cover if desired.

Since the auxiliary mounting pad operates under case pressure, you must use an O-ring to seal the auxiliary pump to the pad. The drive coupling is lubricated with oil from the main pump case.

Spline specifications and torque ratings are shown in the accompanying table.

- All mounting pads meet SAE J744 specifications.
- The sum of main and auxiliary pump torque must not exceed stated maximum.
- All torque values assume a 58 Rc shaft spline hardness on mating pump shaft. Maximum torque is based on maximum torsional strength and 200 000 load reversals.
- Applications with severe vibratory or high G-force (shock) loading may require additional structural support to prevent leaks or mounting flange damage. Refer to *Mounting flange loads*, page 16 for additional information.

*Auxiliary pad<sup>1</sup>*

Pad size	Spline	Minimum spline length mm [in]	Maximum torque N•m [lbf•in]
SAE A	9 tooth 16/32 pitch	13.5 [0.53]	107 [950]
SAE A special	11 tooth 16/32 pitch	13.5 [0.53]	147 [1300]
SAE B	13 tooth 16/32 pitch	14.2 [0.56]	248 [2200]
SAE B-B	15 tooth 16/32 pitch	14.2 [0.56]	347 [3070]

<sup>1</sup>Allowable Auxiliary coupling torque is subject to limitations of the input shaft.



#### AUXILIARY MOUNTING PADS (continued)

#### Auxiliary pump mating dimensions

Pad Size	P	B	C	D	E	F
SAE A mm [in]	82.55 [3.250]	8.1 [0.32]	12.7 [0.500]	44 [1.73]	15 [0.59]	13.5 [0.53]
SAE B mm [in]	101.6 [4.000]	11.4 [0.45]	15.2 [0.60]	46 [1.81]	17.5 [0.69]	14.2 [0.56]

This drawing provides the dimensions for the auxiliary pump mounting flange and shaft. Auxiliary pump mounting flanges and shafts with these dimensions are compatible with the auxiliary mounting pads on Series 42 pumps. For auxiliary pad dimensions, see *Auxiliary mounting pads*, page 56.

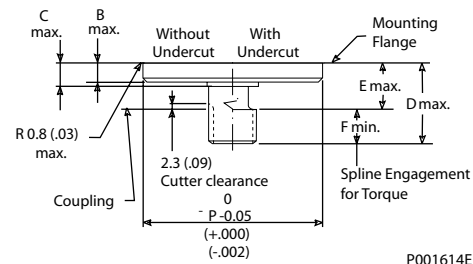

P001614E

#### CONTROL SELECTION

Series 42 pumps use a servo control system with a variety of control options. Manual and Electric Displacement Controls (MDC, EDC and HC-EDC) are feedback controls that provide and maintain a set displacement for a given input. The MDC includes options for a Neutral Start Switch (NSS), backup alarm, and a solenoid override to neutral. Non-Feedback Proportional Electric or Hydraulic controls (NFPE, NFPH) and Forward-Neutral-Reverse (FNR) controls are available to control the pump without mechanical feedback.

All controls provide smooth, stepless positive control of the transmission in either direction. Optional servo supply and drain orifices are available for special response needs.

#### Typical control applications

Machine	Function	MDC	FNR	NFPH	NFPE	HC-EDC	EDC
Roller / compactor	Propel Vibratory drive	● ●	●	●		● ●	● ●
Asphalt paver	Propel Conveyor drive	●	●			● ●	● ●
Skid steer loader	Propel	●		●	●	●	●
Articulated loader	Propel			●	●		
Utility tractor	Propel	●		●	●		
Windrower	Propel	●				●	●
Trencher	Propel Chain drive	● ●	●	●		● ●	● ●
Ag sprayer	Propel	●				●	●
Specialized harvesters (sod, fruit, nut, etc.)	Propel Auxiliary drive	● ●	● ●	●	●	● ●	● ●
Commercial mower	Propel	●		●			
Rock drill	Propel	●				●	●
Drill rig	Drill drive Pull down			● ●			
Sweeper	Propel Fan	● ●	●	●	●	● ●	● ●
Aerial lift	Propel				●	●	●
Fork lift	Propel			●	●		
Brush / stump cutter	Propel Cutter drive	● ●	●	●			
Airport vehicle	Propel			●	●	●	●
Dumper	Propel	●		●			

### MANUAL DISPLACEMENT CONTROL (MDC)

The Manual Displacement Control (MDC) converts a mechanical input signal to a hydraulic signal. The hydraulic signal positions the servo piston, tilting the swashplate to vary the pump's displacement and flow direction.

The position of the swashplate is proportional to the mechanical input signal. The control has mechanical feedback that regulates the servo valve in relation to swashplate position to maintain displacement at the commanded level regardless of changes in system pressure.

The servo control valve has variable geometry porting to regulate swashplate response relative to input command. The control performs small displacement change commands with maximum controllability throughout the entire stroking range of the pump. It completes large displacement change commands with rapid swashplate response. Optional servo supply and drain orifices are available for special response needs.

The control also has a full over-travel spool that allows input at a faster rate than swashplate movement without damage to the control. Any swashplate position error is fed back to the servo valve for instant correction.

#### Features and benefits of MDC

- The MDC is a high gain control: Small movements of the control handle move the servo valve to full open position porting maximum flow to the servo cylinder.
- The full over-travel spool design allows rapid changes in input signal without damaging the control mechanism.
- The MDC provides a fast response with low input force.
- Precision parts provide repeatable and accurate displacement settings.
- Mechanical feedback maintains pump displacement regardless of changes in system pressure.
- The operator is isolated from swashplate vibration.
- The swashplate and servo cylinder, as well as the control valve, are spring centered so the pump returns quickly to neutral in the absence of control input.

The pump returns to neutral:

- if the prime mover is shut down;
- if the external control linkage fails at the control handle;
- if there is a loss of charge pressure.

**MANUAL DISPLACEMENT CONTROL (MDC)**  
 (continued)

**Control input signal**

Moving the control handle to maximum displacement requires a torque of  $1.36 \pm 0.23 \text{ N}\cdot\text{m}$  [ $12 \pm 2 \text{ in}\cdot\text{lbf}$ ]. To prevent damage to the control, provide stops in the linkage to limit maximum travel torque. Maximum allowable input torque is  $17 \text{ N}\cdot\text{m}$  [ $150 \text{ in}\cdot\text{lbf}$ ].

*Handle angle required for swashplate position*

Swashplate position (see graphs)		
Configuration	Swashplate movement begins (point a)	Full displacement reached (point b)
Linear - standard	5.3°	28°
Linear - narrow	4.0°	24°

*Pump displacement versus control lever rotation*

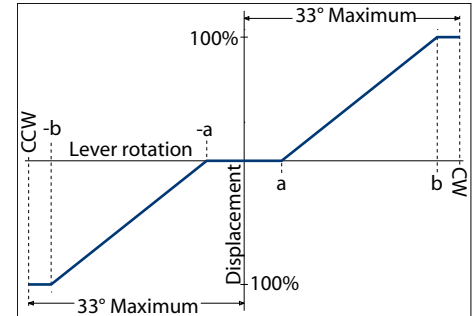

P100405E

**Response time**

You can tailor the time to change from zero to maximum displacement using orifices incorporated in the gasket between the control and pump housing. Using orifices you can match swashplate response to the acceleration and deceleration requirements of your application. Verify proper orifice selection by testing.

*MDC response time (maximum to maximum)*

Frame size (cm <sup>3</sup> )	Fast (no orifice)	Medium	Slow (standard)
28/32	0.5 sec.	1.3 sec.	2.5 sec.
41/51	0.6 sec.	1.6 sec.	2.5 sec.

Neutral to maximum swashplate response is approximately 60% of the time for maximum to maximum sawashplate travel. For other response times please contact your Sauer-Danfoss representative.

*MDC schematic*

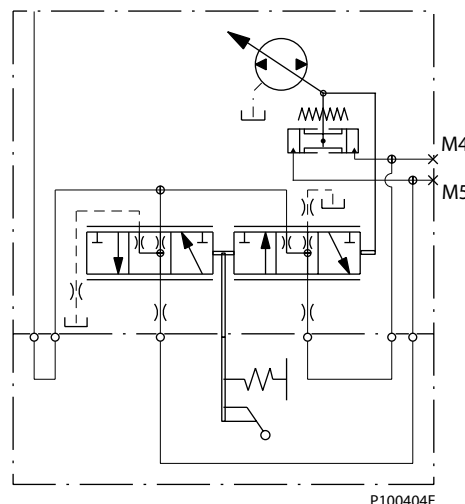

P100404E

*Cross-section of MDC*

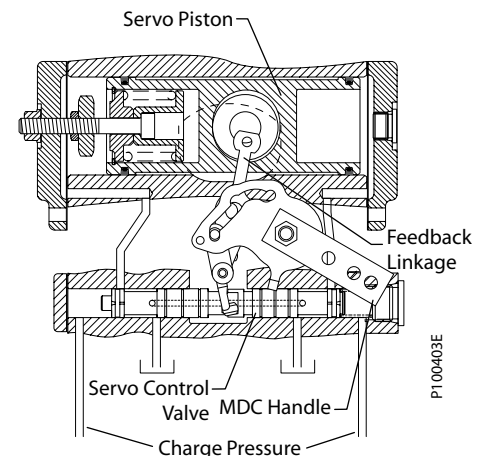

P100403E

**MANUAL DISPLACEMENT CONTROL (MDC)**  
 (continued)

**Control handles**

Either straight or clevis (offset) style control handles are available for the MDC. The straight style handle minimizes the overall height of the pump and control. The clevis style handle provides additional clearance between the handle and control housing and works well for clevis style linkage installations.

Maximum allowable input torque at the control handle is 17 N•m (150 lbf•in). The maximum allowable bending moment is 4 N•m (35 in•lbf).

*MDC handle options*

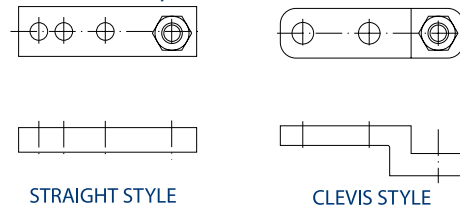

*Pump flow direction with MDC*

Input shaft rotation	CW		CCW	
	CW	CCW	CW	CCW
Handle of rotation	CW	CCW	CW	CCW
Port A flow	Out	In	In	Out
Port B flow	In	Out	Out	In
High pressure servo gauge port	M4	M5	M4	M5

**Electric solenoid override to neutral**

This normally open solenoid valve (C) shunts both ends of the servo piston. This prevents the pump from stroking. This option is ideally suited for operator presence or auto-resume functions without prime mover shut down. This solenoid is available in 12 or 24 Vdc with 2 Amp. maximum current draw. It is available with DIN 43650 terminals or with a Packard Weather-Pack 2-way shroud connector.

*Electric override to neutral specifications*

<b>Solenoid state at override activation</b>	De-energized
<b>Voltage</b>	12 or 24 Vdc
<b>Maximum current</b>	2 A

**Emergency override to neutral with port for brake pressure release**

This solenoid valve (C) operates as the override to neutral above, and drains a spring-applied, hydraulically-released brake (port X7). Energizing the valve allows the pump to operate as normal, while also charging port X7 to release the brake. This option is ideally suited for emergency stop functions without prime mover shut down. The solenoid is available in 12 or 24 Vdc with 2 Amp. maximum current draw. It is available with DIN 43650 terminals or with a Packard Weather-Pack 2-way shroud connector.

*Hydraulic schematic for MDC with override options*

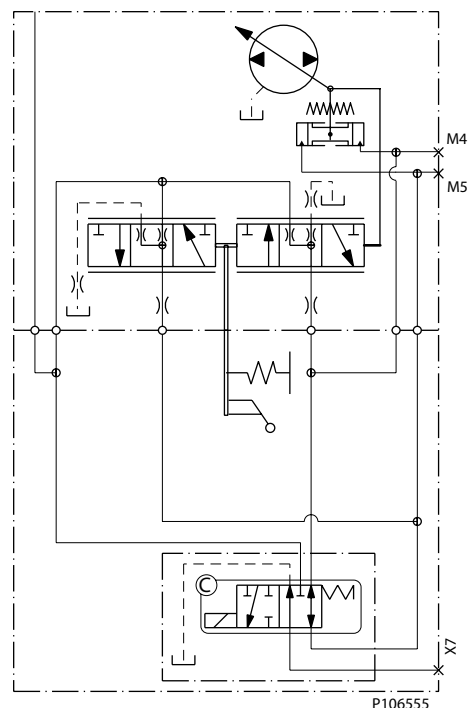

**MANUAL DISPLACEMENT CONTROL (MDC) (continued)**

**Neutral Start Switch (NSS)**

This option provides an electrical switch contact that is closed when the control handle is in its neutral (0°) position. The switch contact opens when the control handle rotates approximately 1.5° to 2° clockwise (CW) or counterclockwise (CCW) from neutral.

The switch is rated for 5 Amp. inductive load at 12 or 24 Vdc. It is available with screw terminals (no connector) or with a Packard Weather-Pack 2-way tower connector.

Wire the NSS in series with the engine starting circuit to ensure the pump is in neutral position before allowing the engine to start.

**NSS with Back-Up Alarm (BUA) switch**

The BUA switch contact is open until the control handle rotates 2.6° to 3.75° from neutral. The BUA switch closes when the control handle rotates either clockwise (CW) or counterclockwise (CCW) from neutral (choose one direction only). The NSS function operates as described above.

The BUA contacts are rated for 2.5 Amp. resistive load at 12 or 24 Vdc. The NSS contacts are rated for 5 Amp. inductive load at 12 or 24 Vdc. This switch is available with screw terminals (no connector) or with a Packard Weather-Pack 4-way tower connector.

Wire the NSS as described above. Wire the BUA switch in series with a back-up alarm to have the alarm sound when the operator moves the pump control handle into reverse.

**Connectors**

For available connectors and dimensions, see outline drawings: *Manual Displacement Control Options*, page 46.

- A. Backup alarm switch contacts (green wire) (closed in reverse)
- B. Neutral start switch w/ backup alarm
- C. Electric solenoid override to neutral w/ brake release
- D. Neutral start switch contacts (black wire) (closed in neutral)

*Neutral start switch specifications*

<b>Switch neutral position</b>	Closed
<b>Voltage</b>	12 or 24 Vdc
<b>Current rating</b>	5 A
<b>Neutral play</b>	± 2°

*Backup alarm switch option*

<b>Switch neutral position</b>	Open
<b>Voltage</b>	12 or 24 Vdc
<b>Current rating</b>	2.5 A
<b>Alarm direction</b>	CW or CCW
<b>Switch closes at</b>	± 2.6 ~ 3.75°

*Hydraulic schematic for MDC with override options and NSS*

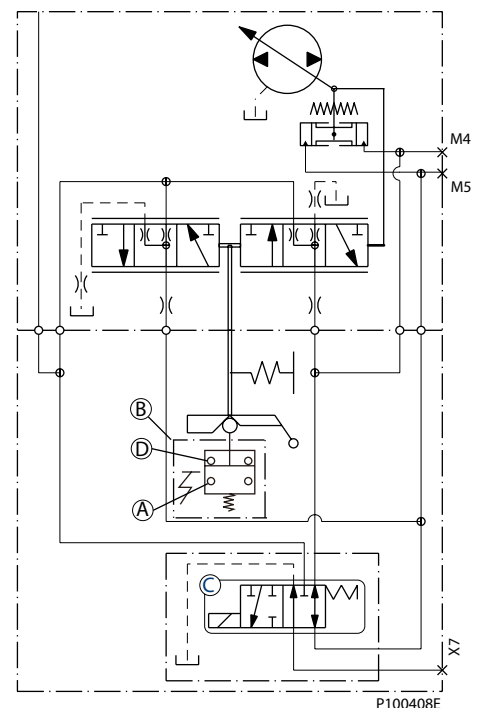

**ELECTRICAL  
 DISPLACEMENT  
 CONTROL (HC-EDC)**

The High Current Electrical Displacement Control (HC-EDC) uses two Proportional Pressure Reducing Valves(PPRV) to provide reducing pilot pressure. The PPRV converts an electrical input signal to a hydraulic input signal to operate a spring centered sensing piston. The sensing piston produces a mechanical input to the servo control valve in the pump housing, which ports hydraulic pressure to either side of the servo piston.

The position of the swashplate is proportional to the electrical input signal. The control has mechanical feedback that regulates the servo valve in relation to swashplate position to maintain displacement at the commanded level regardless of changes in system pressure. Any swashplate position error is fed back to the servo control valve for instant correction.

The servo control valve has variable geometry porting to regulate swashplate response relative to input command. The control performs small displacement change commands with maximum controllability throughout the entire stroking range of the pump. It completes large displacement change commands with rapid swashplate response. Optional servo supply and drain orifices are available for special response needs

*Cross-section of HC-EDC*

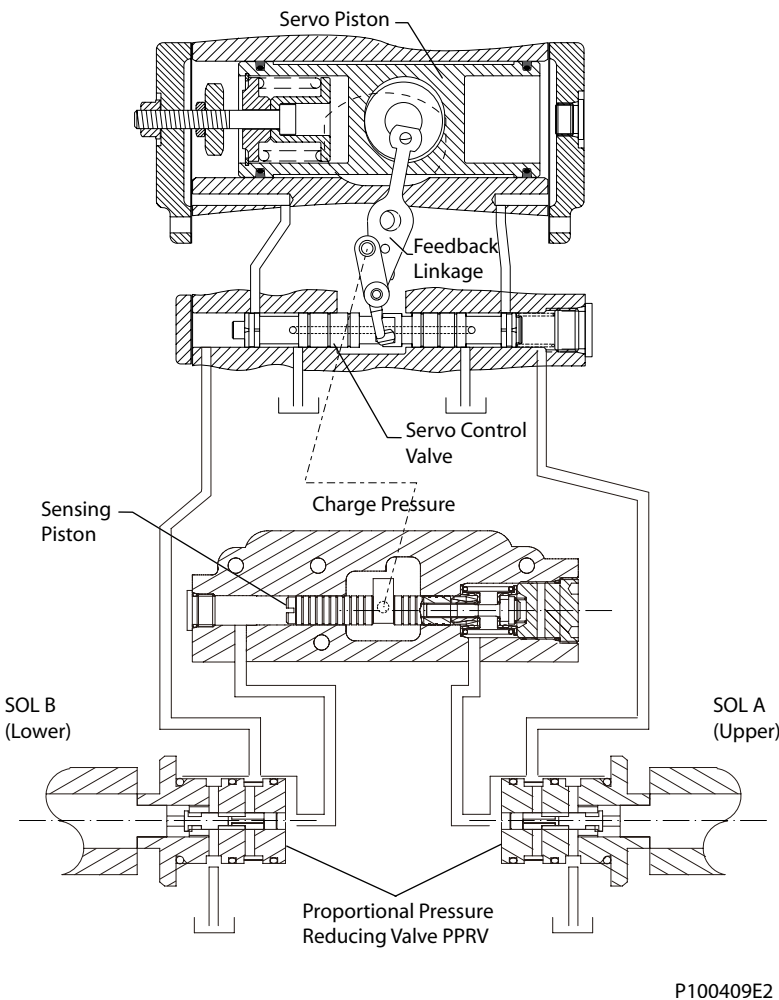

*HC-EDC hydraulic schematic*

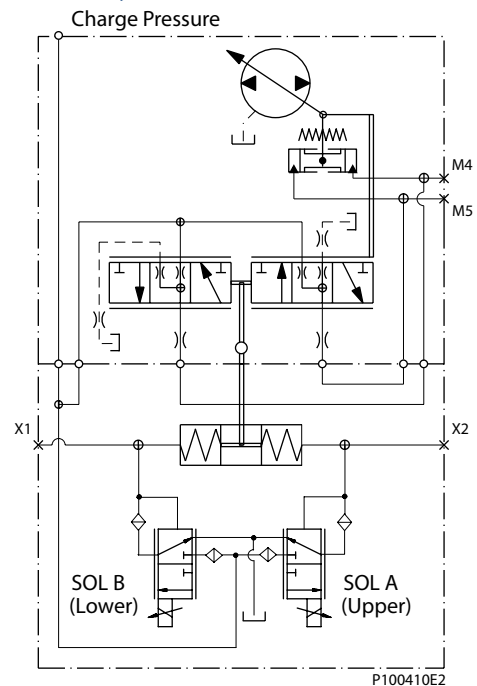

*Pump flow direction with HC-EDC*

Input shaft rotation	CW		CCW	
	A	B	A	B
Solenoid energized	A	B	A	B
Port A flow	Out	In	In	Out
Port B flow	In	Out	Out	In
High pressure servo gauge port	M4	M5	M4	M5
High pressure EDC pilot gauge	X2	X1	X2	X1

**ELECTRICAL  
 DISPLACEMENT  
 CONTROL (HC-EDC)  
 (continued)**

**Features and benefits of HC-EDC**

- HC-EDC is a control driven by a pair of Proportional Pressure Reducing Valves (PPRV).
- The control requires Pulse Width Modulation(PWM) with a recommended 200Hz signal.
- PWM allows for more precise control of current to the proportional solenoids.
- A full over-travel servo valve allows rapid changes in input signal voltages without damaging the control mechanism.
- Precision parts provide repeatable and accurate displacement settings.
- The swashplate and servo piston, as well as the servo control valve, are spring centered so the pump returns quickly to neutral in the absence of control input
- Simplified Control Design.

The pump returns to neutral:

- if the prime mover is shut down;
- if the control input signal is lost;
- if there is a loss of charge pressure;

**Response time**

You can tailor the time to change from zero to maximum displacement using orifices incorporated in the gasket between the control and pump housing. Using orifices you can match swashplate response to the acceleration and deceleration requirements of your application. Verify proper orifice selection by testing.

*HC-EDC response time  
 (maximum to maximum)*

Frame size (cm <sup>3</sup> )	Fast (no orifice)	Medium	Slow (standard)
28/32	0.5 sec.	1.3 sec.	2.5 sec.
41/51	0.6 sec.	1.6 sec.	2.5 sec.

Neutral to maximum swashplate response is approximately 60% of the time for maximum to maximum sawashplate travel. For other response times please contact your Sauer-Danfoss representative.

**ELECTRICAL  
 DISPLACEMENT  
 CONTROL (HC-EDC)  
 (continued)**

**Control input signal**

The figure and table below relate the input electrical signal to pump displacement, (swashplate position), for each coil configuration.

*Pump displacement versus electrical signal*

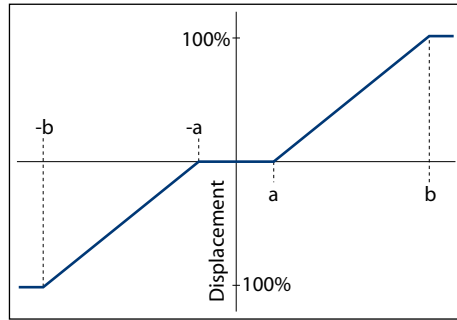

P001015E

**Control signal requirements**

*Control current*

Voltage	a* mA	b mA	Pin connection
12V	300	750	any other
24V	150	375	

\*Factory test current, for vehicle movement or application actuation expect higher value.

*Coil specifications*

Voltage (V)	12 Vdc	24 Vdc
Rated current at 20°C [68 °F]	1330 mA	665 mA
Rated power	16 W	16 W
Coil resistance at 20°C [68 °F]	9 Ω	36 Ω
Coil resistance at 60°C [140 °F]	12.4 Ω	49.7 Ω
PWM frequency range	100 - 200 Hz	100 - 200 Hz
Recommended PWM frequency	200 Hz	200Hz

**Connectors and port locations**

Refer to outline drawings: *Electrical displacement control (HC-EDC) options*, page 53.



**ELECTRICAL  
 DISPLACEMENT  
 CONTROL (EDC)**

The Electrical Displacement Control (EDC) uses an electrohydraulic Pressure Control Pilot (PCP) stage to provide a differential pilot pressure. The PCP stage converts an electrical input signal to a hydraulic input signal to operate a spring centered sensing piston. The sensing piston produces a mechanical input to the servo control valve which ports hydraulic pressure to either side of the servo piston. The servo piston operates the swashplate varying the pump's displacement and flow direction.

The position of the swashplate is proportional to the electrical input signal. The control has mechanical feedback that regulates the servo valve in relation to swashplate position to maintain displacement at the commanded level regardless of changes in system pressure. Any swashplate position error is fed back to the servo valve for instant correction.

The servo control valve has variable geometry porting to regulate swashplate response relative to input command. The control performs small displacement change commands with maximum controllability throughout the entire stroking range of the pump. It completes large displacement change commands with rapid swashplate response. Optional servo supply and drain orifices are available for special response needs.

*Cross-section of EDC*

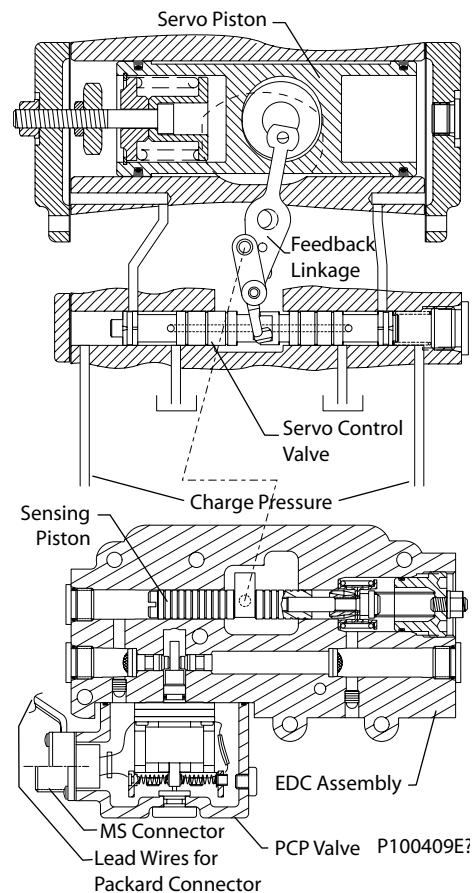

*EDC hydraulic schematic*

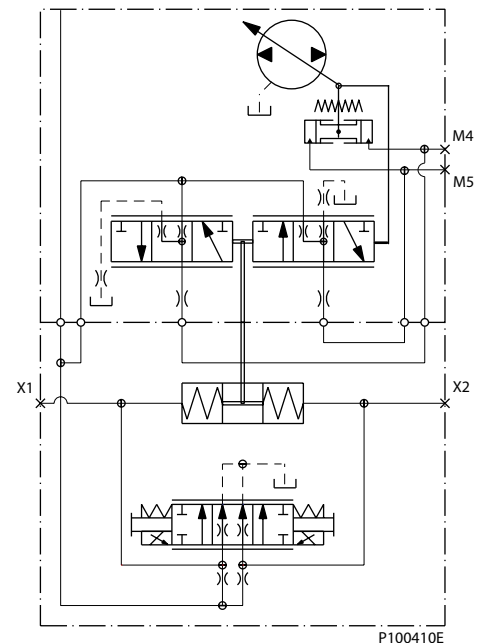

*Pump flow direction with EDC*

Input shaft rotation	CW		CCW	
	A (C)	B (D)	A (C)	B (D)
Port A flow	Out	In	In	Out
Port B flow	In	Out	Out	In
High pressure servo gauge port	M4	M5	M4	M5
High pressure EDC pilot gauge	X2	X1	X2	X1

**ELECTRICAL  
 DISPLACEMENT  
 CONTROL (EDC)  
 (continued)**

**Features and benefits of EDC**

- The EDC is a high gain control. Small changes in input current move the servo valve to full open position porting maximum flow to the servo cylinder.
- Silicon oil filled pilot stage lengthens control life by preventing moisture ingress and dampening component vibrations.
- The majority of all EDC's are equipped with dual coil pilot stages. With the dual coil EDC, you may use a single coil or both coils, either in series or in parallel.
- A full over-travel servo valve allows rapid changes in input signal voltages without damaging the control mechanism.
- Precision parts provide repeatable and accurate displacement settings.
- Mechanical feedback maintains pump displacement regardless of changes in system pressure.
- The control does not require Pulse Width Modulation (PWM), although performance is optimum using a 200 Hz signal.
- The swashplate and servo piston, as well as the servo control valve, are spring centered so the pump returns quickly to neutral in the absence of control input.

The pump returns to neutral:

- if the prime mover is shut down;
- if the control input signal is lost;
- if there is a loss of charge pressure.

**Response time**

You can tailor the time to change from zero to maximum displacement using orifices incorporated in the gasket between the control and pump housing. Using orifices you can match swashplate response to the acceleration and deceleration requirements of your application. Verify proper orifice selection by testing.

*EDC response time (maximum to maximum)*

Frame size (cm <sup>3</sup> )	Fast (no orifice)	Medium	Slow (standard)
28/32	0.5 sec.	1.3 sec.	2.5 sec.
41/51	0.6 sec.	1.6 sec.	2.5 sec.

Neutral to maximum swashplate response is approximately 60% of the time for maximum to maximum sawashplate travel. For other response times please contact your Sauer-Danfoss representative.

**ELECTRICAL  
 DISPLACEMENT  
 CONTROL (EDC)  
 (continued)**

**Control input signal**

The table relates input signal to swashplate position for each coil configuration.

**Connectors and port locations**

Refer to outline drawings: *Electrical displacement control (EDC) options*, page 54.

*Pump displacement versus electrical signal*

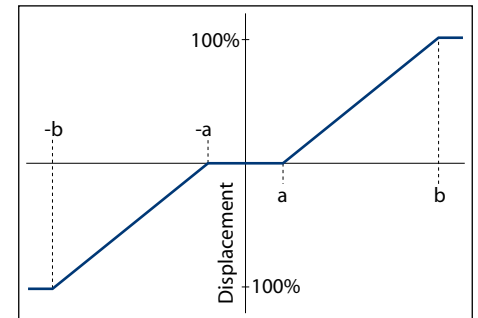

P001015E

**Coil options**

*EDC signal required for swashplate position*

Coil configuration	Swashplate position		Pin connection
	Movement begins (point a) mA at VDC	Full displacement reached (point b) mA at VDC	
Single coil	14 ± 5	85 ± 18	A+B or C+D
Dual coil in series	7 ± 3	43 ± 9	A+D (connect C+B)
Dual coil in parallel	14 ± 5	85 ± 18	A C + B D

*EDC input impedance*

<b>Coil type</b>	Normal current
<b>Coil resistance at 24 °C [75 °F]</b>	Coil A/B: 20 Ω Coil C/D: 16 Ω
<b>Resistance at 104°C [220 °F]</b>	Coil A/B: 24 Ω Coil C/D: 20 Ω
<b>Maximum input current</b>	350 mA at 6 Vdc

**NON-FEEDBACK,  
 PROPORTIONAL  
 HYDRAULIC (NFPH)  
 CONTROL**

The Non-Feedback Proportional Hydraulic (NFPH) control is a hydraulic displacement control in which an input signal pressure directly controls the pump servo piston to set pump displacement.

Series 42 pumps with NFPH control have a special servo cylinder capable of providing proportional control with a hydraulic input.

Swashplate position is proportional to the differential signal pressure at ports X1 and X2, but displacement is also dependent on pump speed and system pressure. This characteristic of non-feedback controls provides a natural power limiting function by reducing the pump swashplate angle as system pressure increases. The accompanying graph shows typical operating characteristics.

**Features and benefits of the NFPH control**

- Eliminates mechanical linkage for flexibility of control design
- Power limiting characteristic reduces machine power requirements
- Compatible with dual axis joysticks for dual path applications
- Smooth operation

**Connectors and port locations**

Refer to outline drawings.

*NFPH pump displacement to input signal*

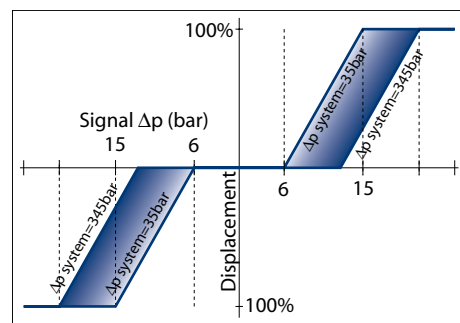

*Non-feedback proportional hydraulic control schematic*

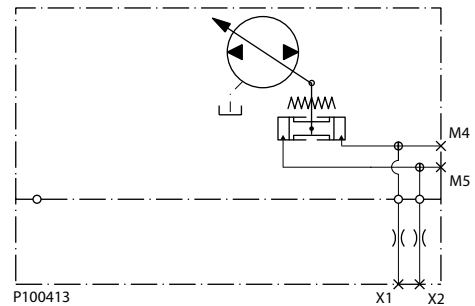

*Pump displacement versus signal pressure*

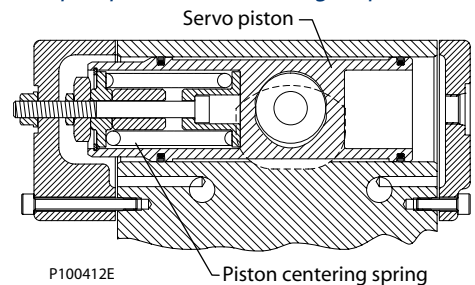

*Pump flow direction with NFPH control*

Input shaft rotation	CW		CCW	
Higher pressure at port:	X1	X2	X1	X2
Port A flow	Out	In	In	Out
Port B flow	In	Out	Out	In
High servo gauge port	M4	M5	M4	M5

**NON-FEEDBACK,  
 PROPORTIONAL  
 ELECTRIC (NFPE)  
 CONTROL**

The Non-Feedback Proportional Electric (NFPE) control is an electric control in which an electric input signal activates one of two solenoids that port charge pressure to either side of the servo piston.

Series 42 pumps equipped with NFPE control have a special servo cylinder capable of providing proportional control with an electric input.

Swashplate position is proportional to the input signal current, but displacement is also dependent on pump speed and system pressure. This characteristic of non-feedback controls provides a natural power limiting function by reducing the pump swashplate angle as system pressure increases. The accompanying graph shows typical operating characteristics.

**Features of the NFPE control**

- Proportional electric control
- Eliminates mechanical linkage for flexibility of control design
- Power limiting characteristic reduces machine power requirements
- Smooth operation

**Input signal requirements**

The NFPE control requires a 200 Hz Pulse-Width-Modulated (PWM) input current to optimize performance. The minimum PWM frequency is 80 Hz. Coil resistance is 5.6 Ω at 22°C. Limit current to 1.5A (12V dc)

The NFPE control uses AMP Junior Power Timer connectors. The solenoids are compatible with Sauer-Danfoss microprocessors, electric circuit boards, and control handles.

**Connectors and port locations**

Refer to outline drawings.

*NFPE pump displacement to input signal*

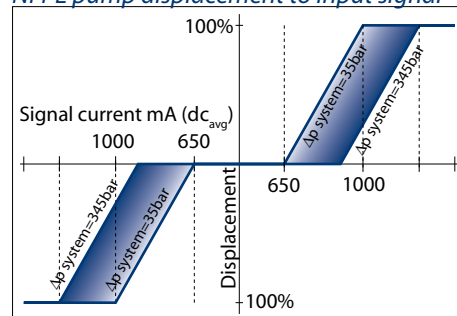

P100417E

*NFPE hydraulic schematic*

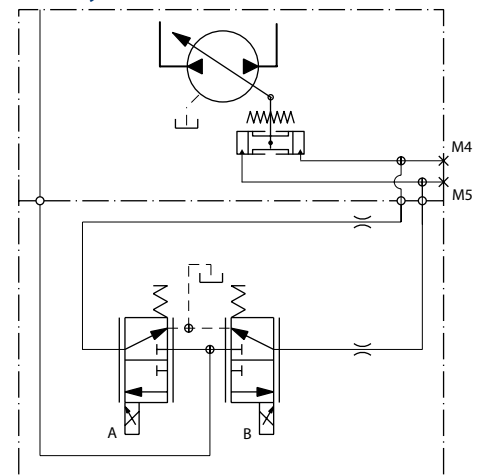

P100416E

*NFPE control on series 42 pump  
 (for 28cc)*

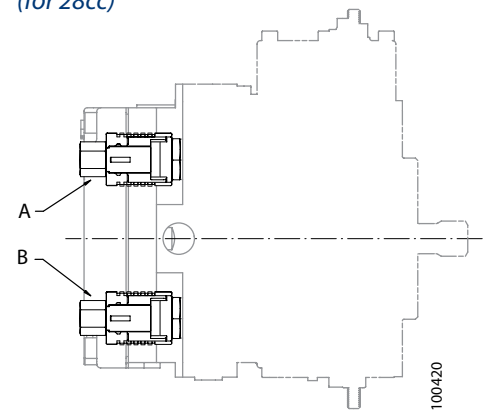

P100420

*Pump flow direction with NFPE control*

Input shaft rotation	CW		CCW	
<b>Solenoid energized</b>	A	B	A	B
<b>Port A flow</b>	Out	In	In	Out
<b>Port B flow</b>	In	Out	Out	In
<b>High pressure servo gauge port</b>	M4	M5	M4	M5

**FORWARD, NEUTRAL,  
 REVERSE, (FNR) CONTROL**

The Forward-Neutral-Reverse (FNR) control uses a solenoid-operated 3-position, 4-way valve to control pump displacement and flow direction. The FNR control is a non-feedback, non-proportional, 3-position control.

When a solenoid is energized, charge pressure flows to one end of the pump servo piston, which strokes the swashplate to maximum angle. Which solenoid is energized determines the direction of pump flow (see table).

**Features and benefits of FNR control**

- Electric control
- If voltage is lost, the pump returns to neutral
- If charge pressure is lost, the pump returns to neutral
- Simple, low-cost design
- Ideal for applications that do not require proportional control

**Input signal requirements**

The solenoids are available in 12 or 24 Vdc. Maximum power is 30 Watts. They are available with DIN 43650 terminals. An AMP Jr. Power Timer connector is also available.

**Connectors and port locations**

Refer to outline drawings.

*Pump displacement to electrical signal*

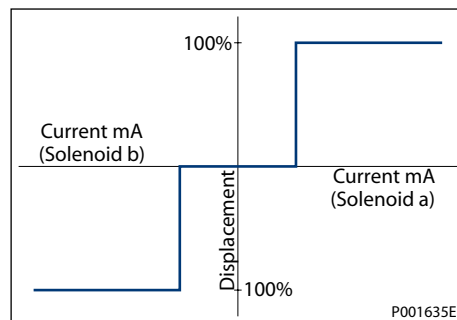

*Pump flow direction with FNR control*

Input shaft rotation	CW		CCW	
	a	b	a	b
Solenoid energized	a	b	a	b
Port A flow	Out	In	In	Out
Port B flow	In	Out	Out	In
High pressure servo gage port	M4	M5	M4	M5

*FNR on series 42 pump (for 41/51cc)*

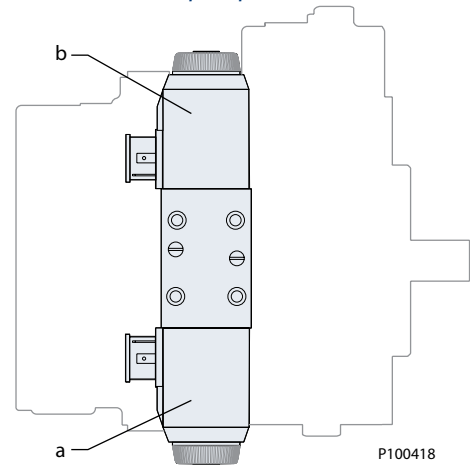

*FNR hydraulic schematic*

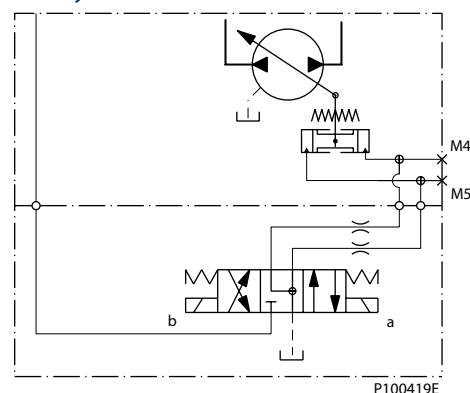

FRAME SIZE 28/32

Base unit with manual displacement control (MDC) - Port/Housing Style A

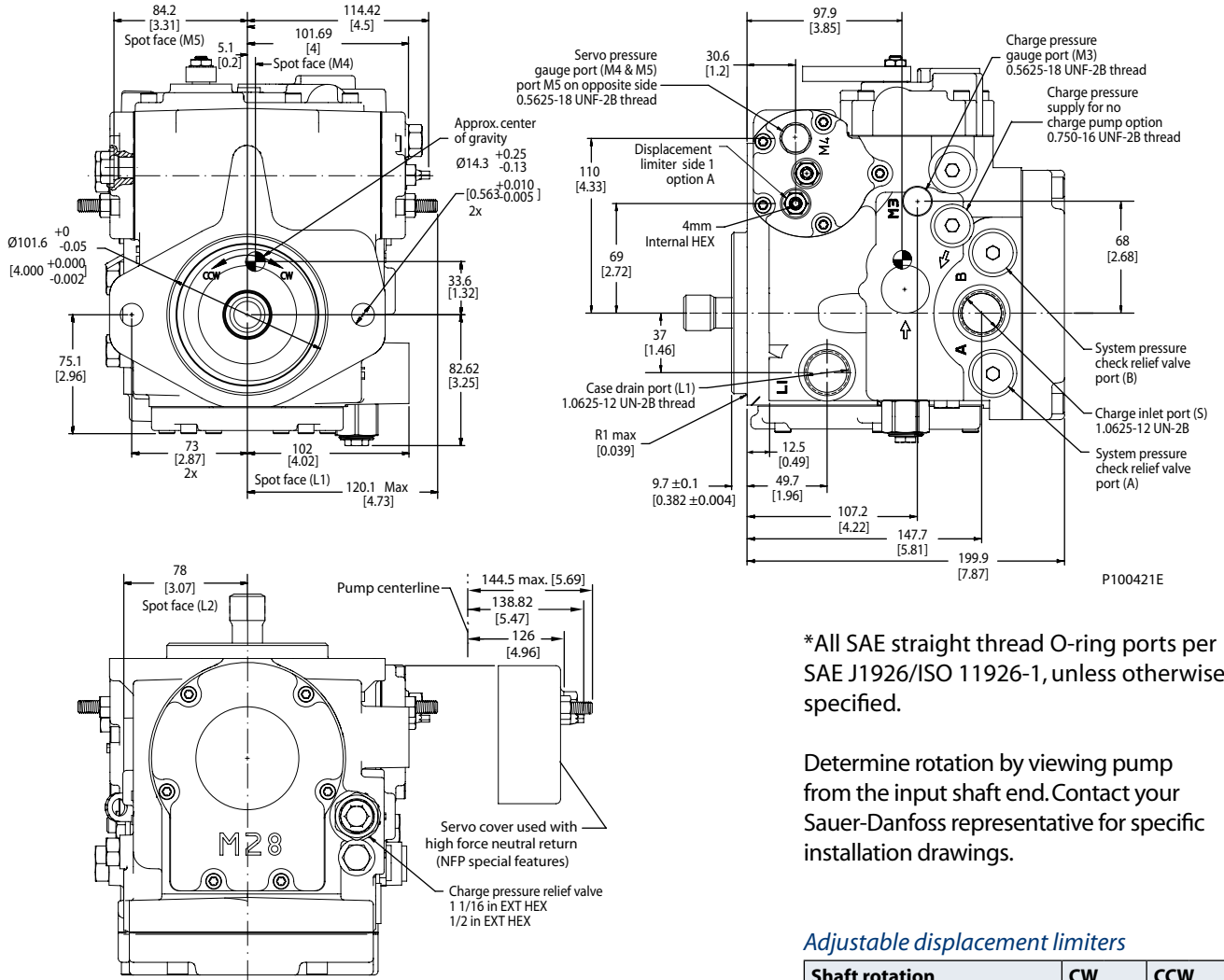

\*All SAE straight thread O-ring ports per SAE J1926/ISO 11926-1, unless otherwise specified.

Determine rotation by viewing pump from the input shaft end. Contact your Sauer-Danfoss representative for specific installation drawings.

Adjustable displacement limiters

Shaft rotation	CW		CCW	
Displacement limiter side	1	2	1	2
Limited flow through port	B	A	A	B



**FRAME SIZE 28/32**  
**(continued)**

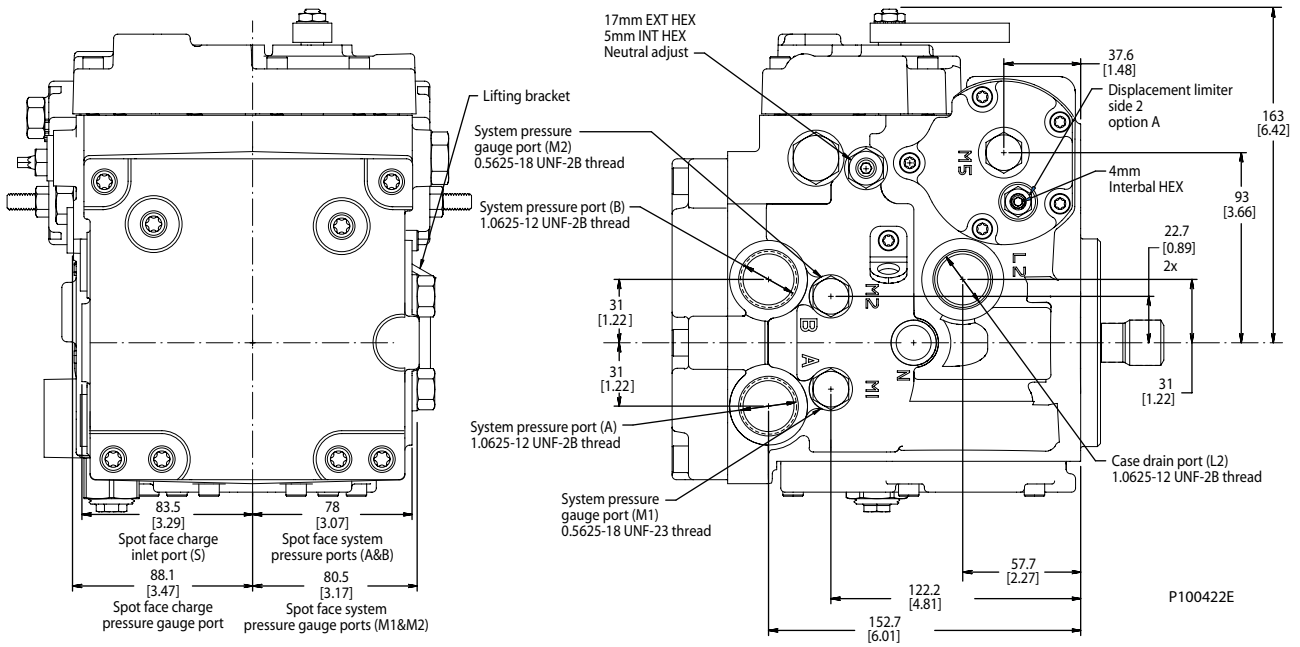
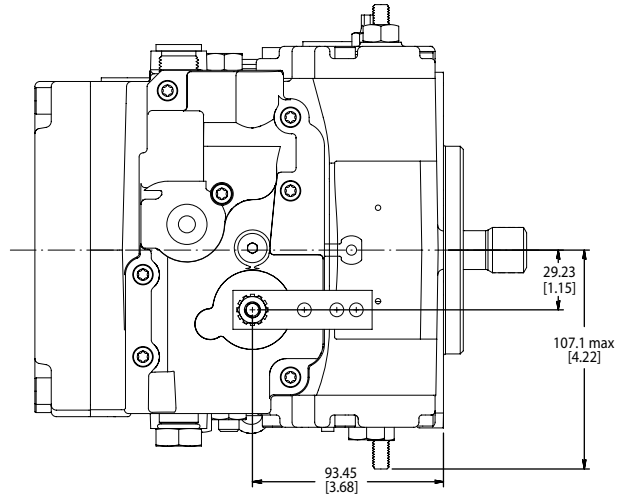



FRAME SIZE 41/51

Base unit with manual displacement control (MDC) - Port/Housing Style A

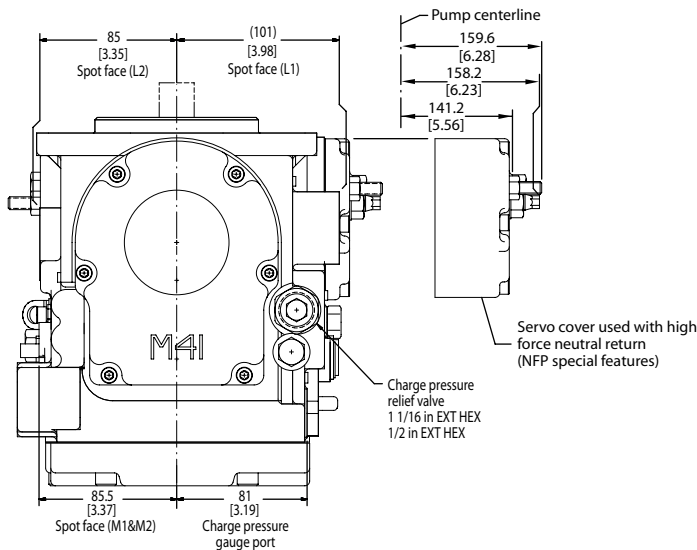
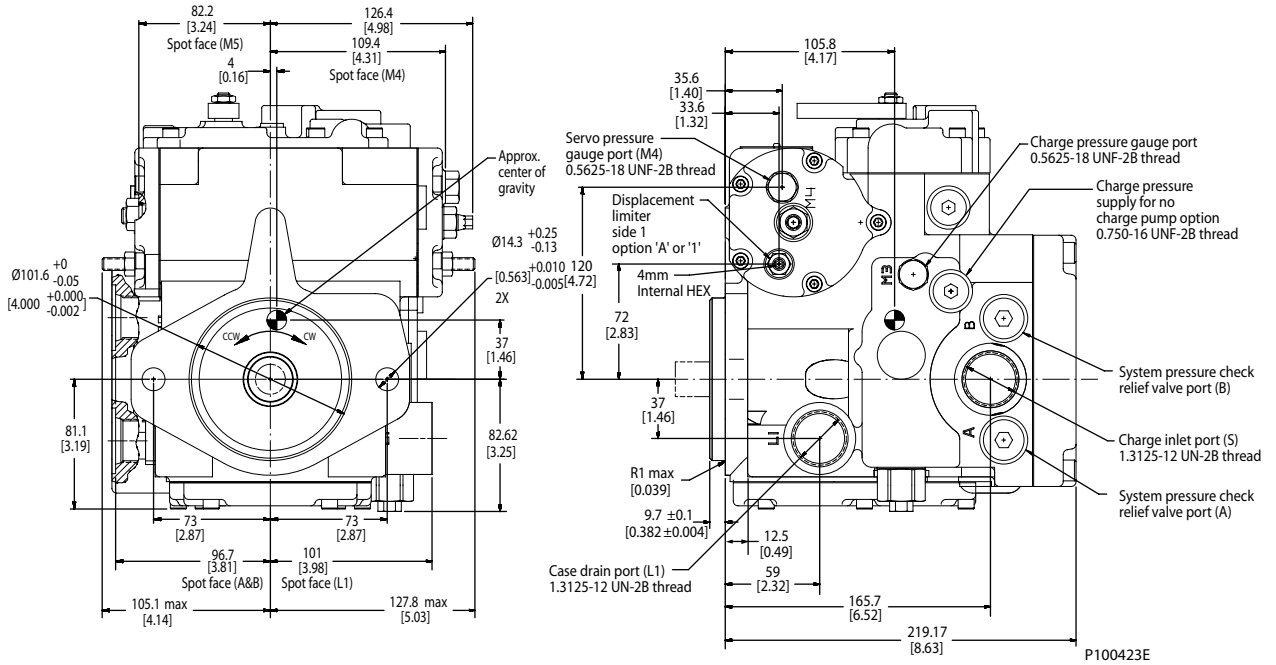

\*All SAE straight thread O-ring ports per SAE J1926/ISO 11926-1, unless otherwise specified.

Determine rotation by viewing pump from the input shaft end. Contact your Sauer-Danfoss representative for specific installation drawings.

Adjustable displacement limiters

Shaft rotation	CW		CCW	
Displacement limiter side	1	2	1	2
Limited flow through port	B	A	A	B



**FRAME SIZE 41/51**  
**(continued)**

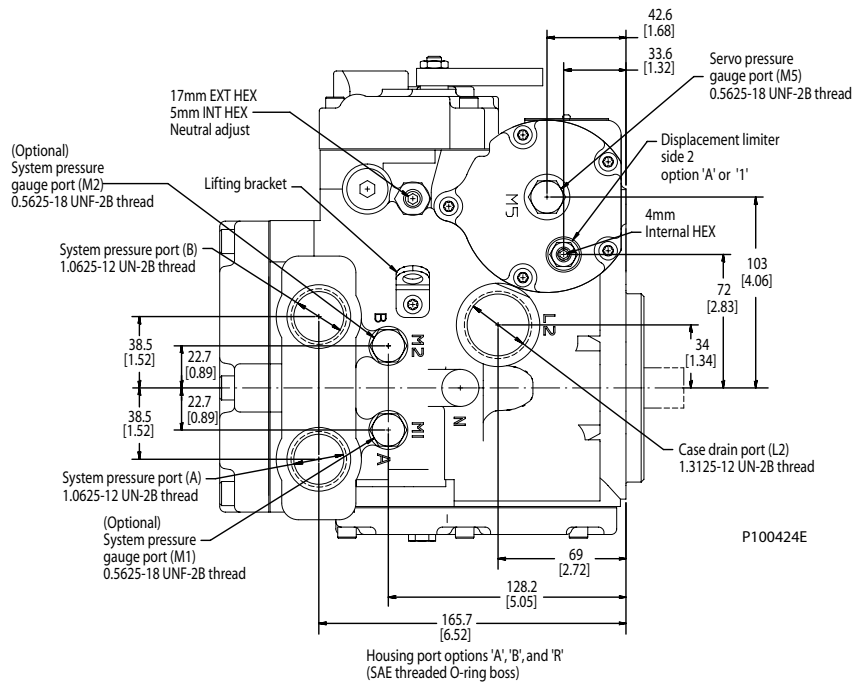
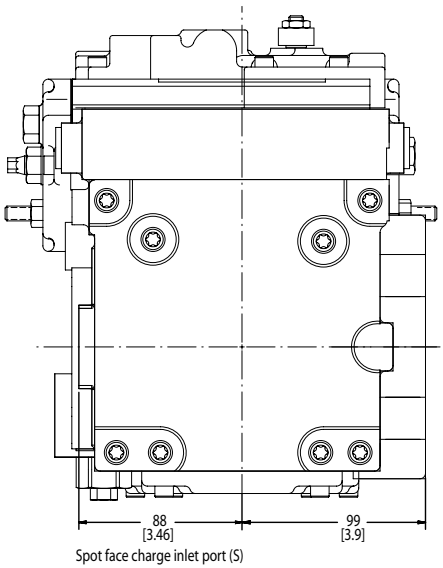
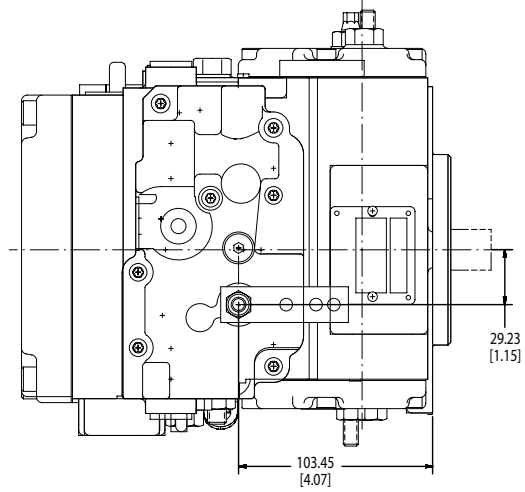

**SHAFT OPTIONS**

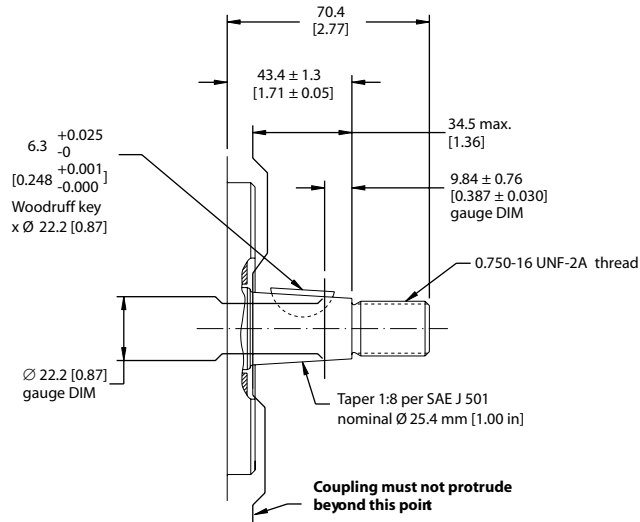
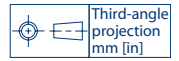

OPTION K: TAPERED SHAFT (41/51 cm<sup>3</sup> models only)

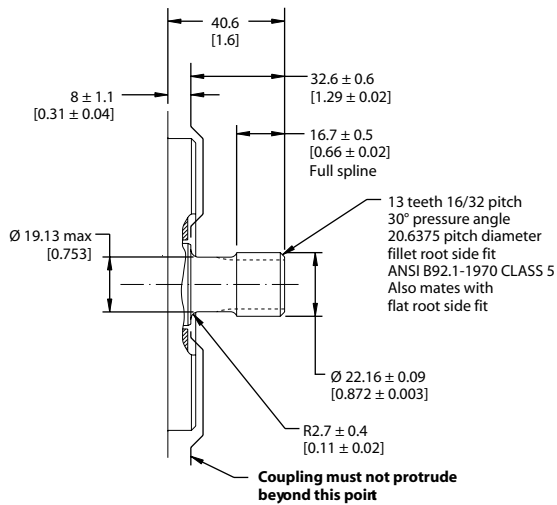

OPTION C: SPLINED SHAFT

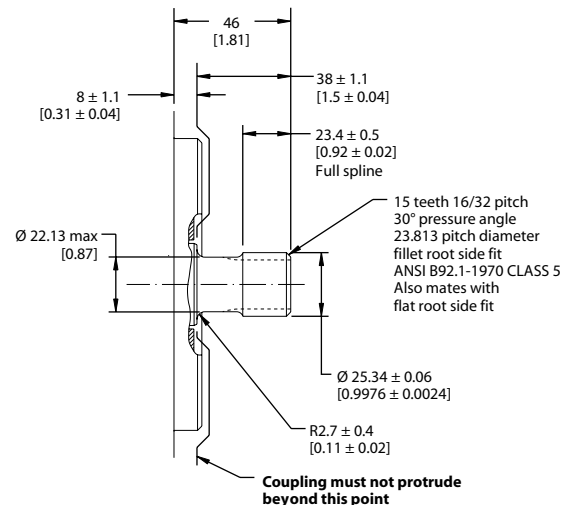

OPTION D: SPLINED SHAFT

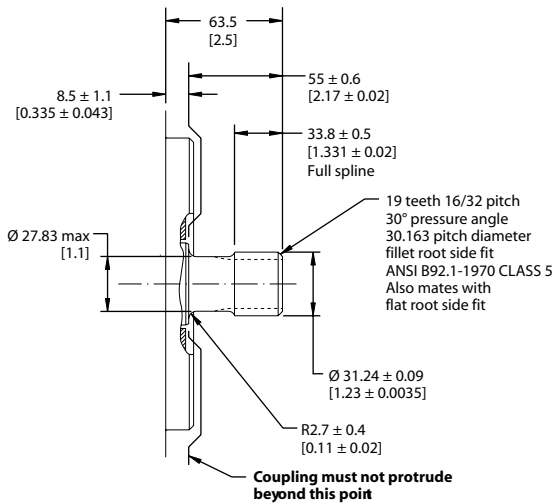

OPTION E: SPLINED SHAFT (41/51 cm<sup>3</sup> models only)

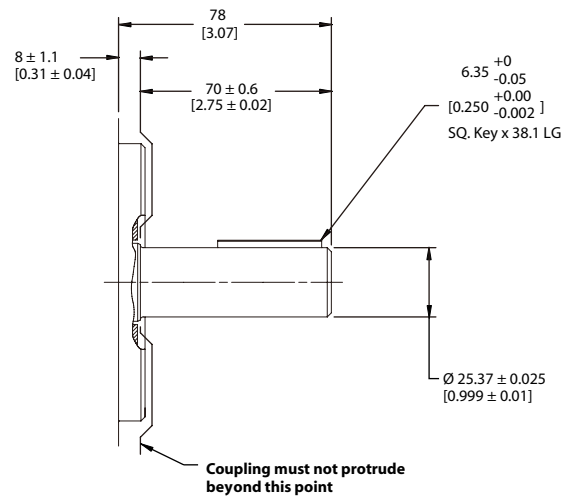

OPTION G: STRAIGHT ROUND KEY

**FILTRATION OPTIONS**

**Suction filtration adapter - option G**

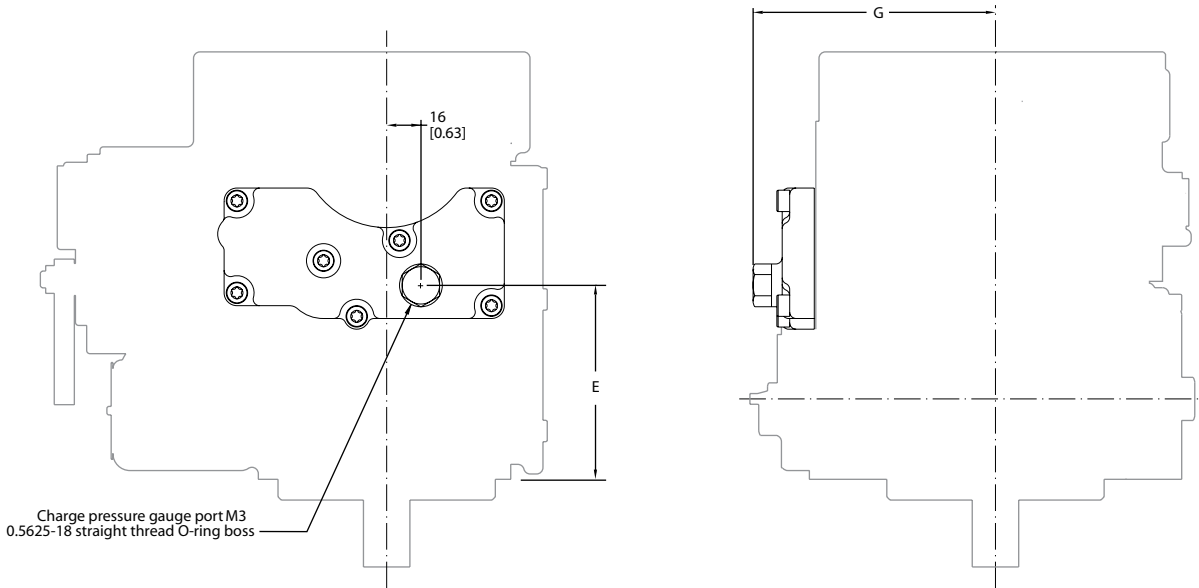

*Lettered dimensions*

Frame size	E	G
28/32	90.7[3.57]	113 [4.45]
41/51	101[3.97]	118.5 [4.67]

**Charge pressure filtration adapter - full filter flow - option B**

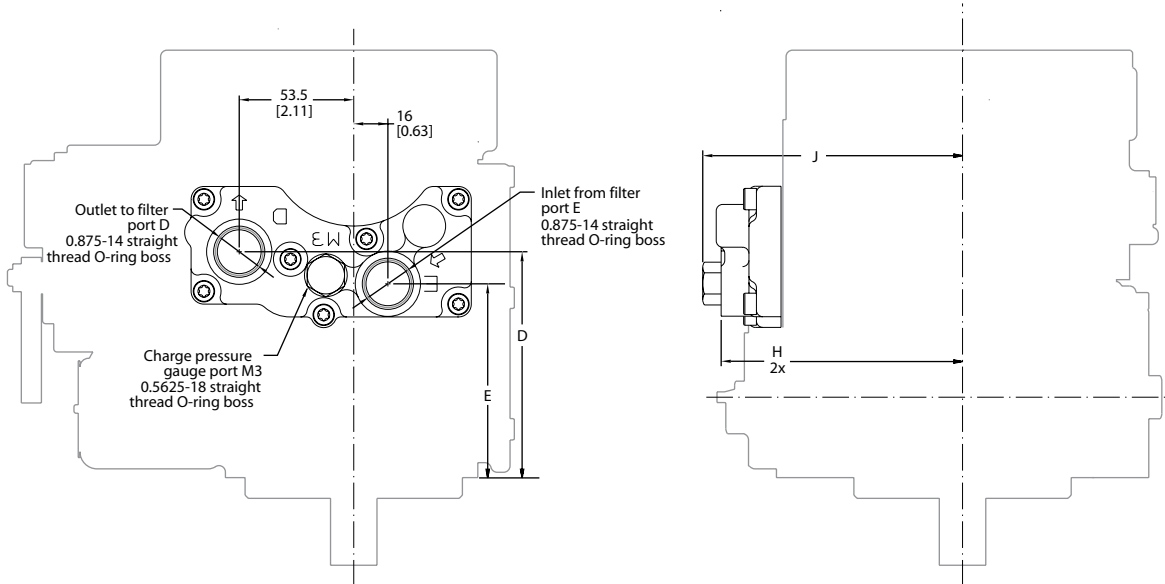

P100425E

*Lettered dimensions*

Frame size	D	E	H	J
28/32	105.7 [4.16]	91.2 [3.59]	112.4 [4.43]	123.3 [4.85]
41/51	116 [4.57]	101.5 [4.00]	117.9 [4.64]	128.8 [5.07]

\*All SAE straight thread O-ring ports per SAE J1926/ISO 11926-1, unless otherwise specified.

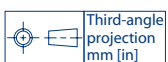

**FILTRATION OPTIONS**  
 (continued)

**No charge pump - option X**

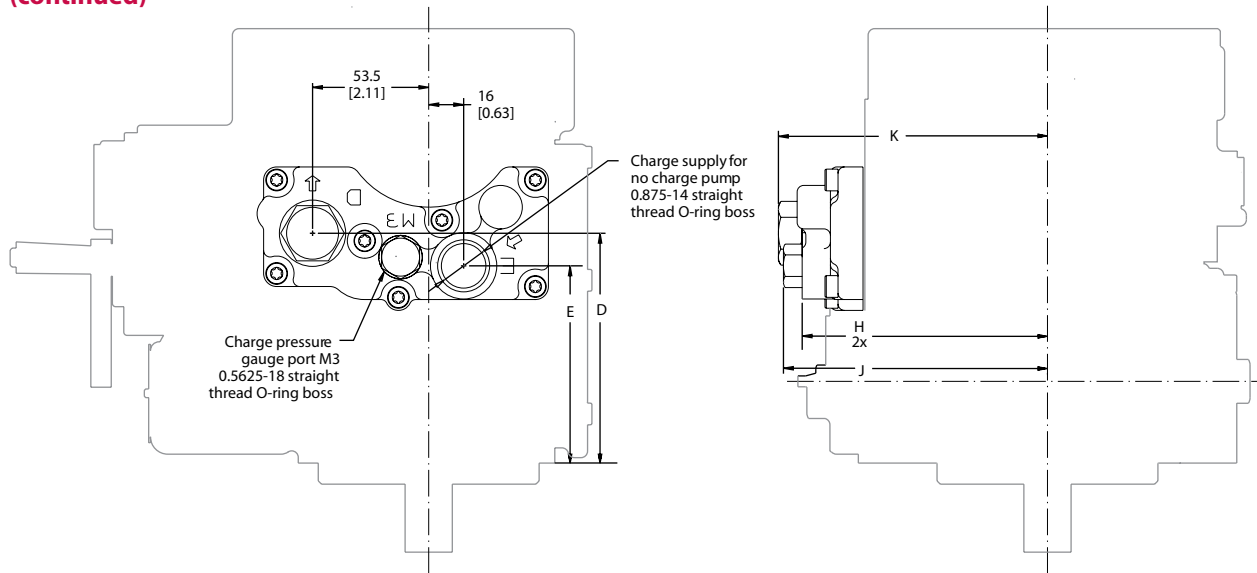

*Lettered dimensions*

Frame size	D	E	H	J	K
28/32	105.7 [4.16]	91.2 [3.59]	112.4 [4.43]	123.3 [4.85]	125.7 [4.95]
41/51	116 [4.57]	101.5 [4.00]	117.9 [4.64]	128.8 [5.07]	131.3 [5.17]

**Charge pressure filtration - full filter flow (no adapter) - option F**

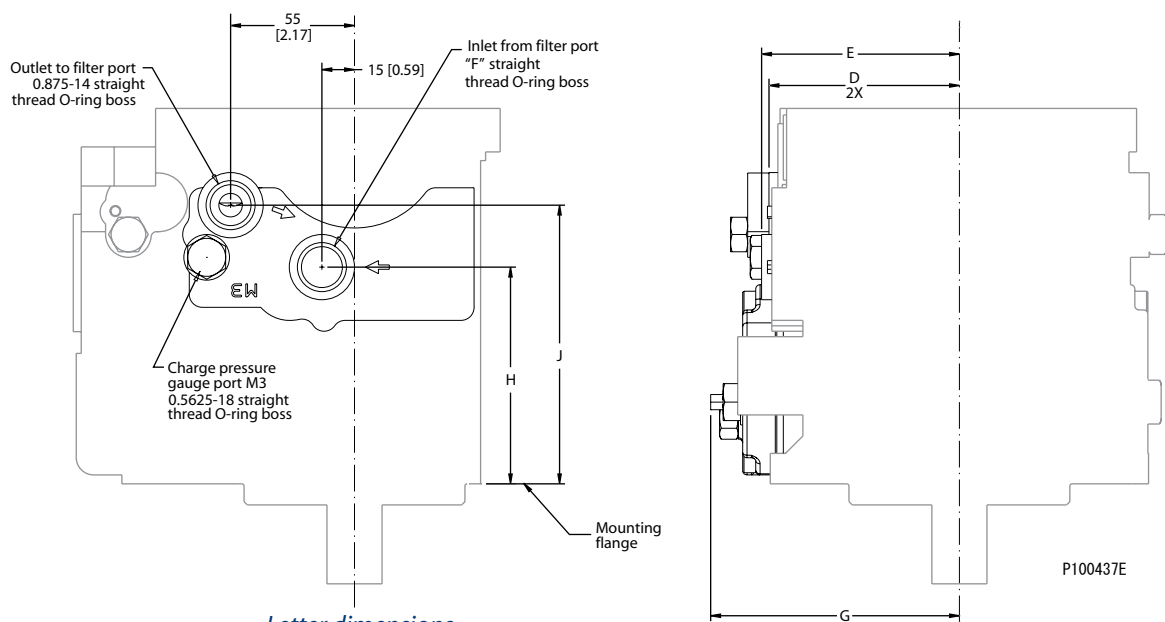

*Letter dimensions*

Frame size	D	E	F	G	H	J
28/32	87.6 [3.45]	91 [3.58]	.875 -14	114.42 [4.5]	99.7 [3.93]	129.2 [5.09]
41/51	93.5 [3.68]	95.3 [3.75]	.750 -16	122.12 [4.81]	110 [4.33]	141 [5.55]

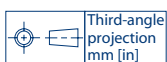

\*All SAE straight thread O-ring ports per SAE J1926/ISO 11926-1, unless otherwise specified.

**CONTROL MODULES**

**Manual displacement control (MDC) options**

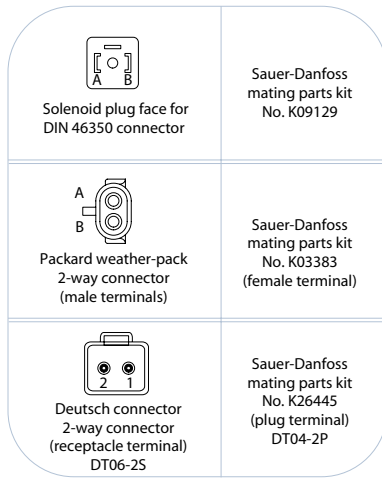
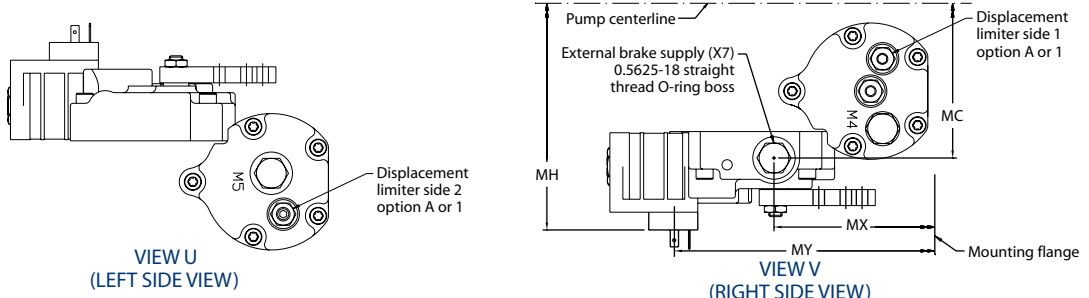

**ELECTRIC NEUTRAL OVERRIDE AND BRAKE RELEASE CONNECTORS**

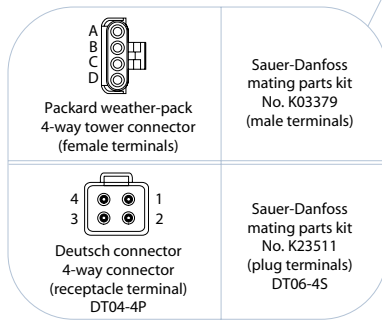

**NEUTRAL START SWITCH AND BACKUP ALARM**

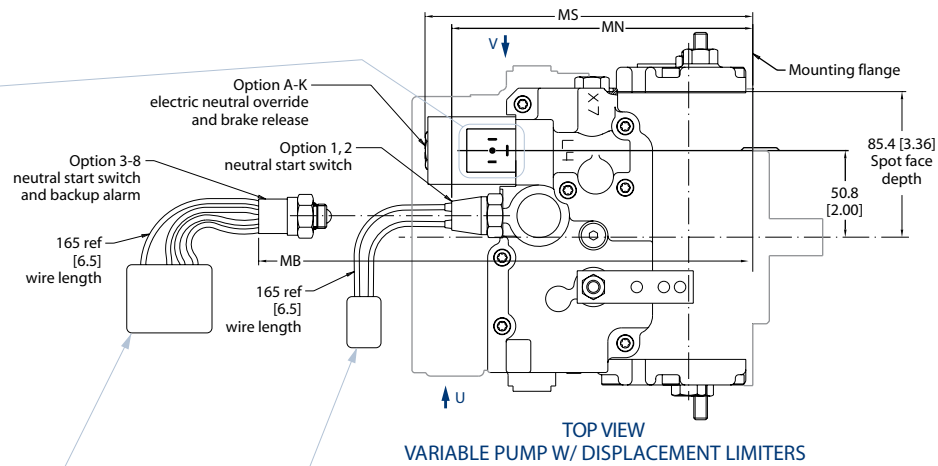

**TOP VIEW  
 VARIABLE PUMP W/ DISPLACEMENT LIMITERS**

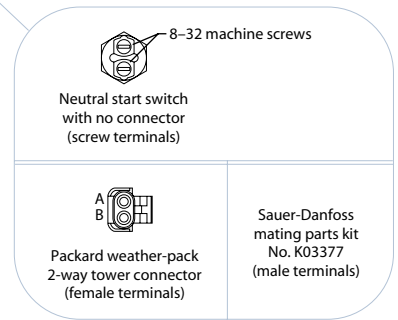

**NEUTRAL START SWITCH CONNECTORS**

Terminals 1&2, A&B (Neutral Start)  
 Normally "ON" Switch  
 Wire Color Black

Terminals 3&4, C&D (Backup Alarm)  
 Normally "OFF" Switch  
 Wire Color Green

P100431E

*Manual displacement control dimensions*

Frame size	MB	MC	MH	MN	MS	MX	MY
28/32	177.4 [6.98]	127.2 [5.01]	169.4 [6.67]	175.4 [6.91]	192.7 [7.58]	94.3 [3.71]	152.8 [6.02]
41/51	187.4 [7.38]	144.2 [5.68]	186.4 [7.34]	185.4 [7.30]	202.7 [7.98]	104.3 [4.11]	162.8 [6.41]

\*All SAE straight thread O-ring ports per SAE J1926/ISO 11926-1, unless otherwise specified.



**CONTROL MODULES**  
 (continued)

**Manual displacement control (MDC) options**

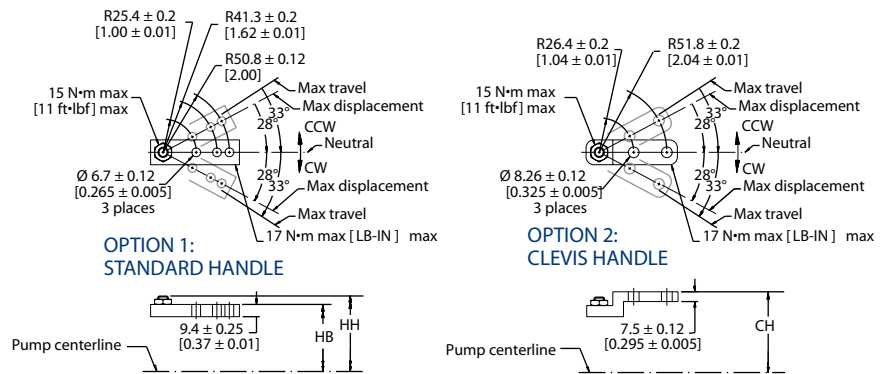

P100431E\_2

*Control handle dimensions*

Frame size	HB	HH	CH
28/32	156.4 [6.16]	163 [6.42]	166.1 [6.54]
41/51	173.4 [6.83]	180 [7.09]	183.1 [7.21]

\*All SAE straight thread O-ring ports per SAE J1926/ISO 11926-1, unless otherwise specified.



**CONTROL MODULES**  
 (continued)

**Electric control (FNR) options**

**FRAME SIZE 28/32**

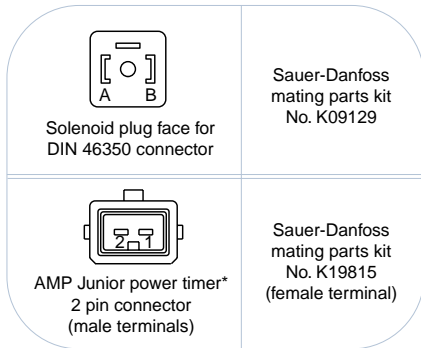

**FNR CONNECTORS**

\* Special temperature requirements, see your Sauer-Danfoss representative when considering this option

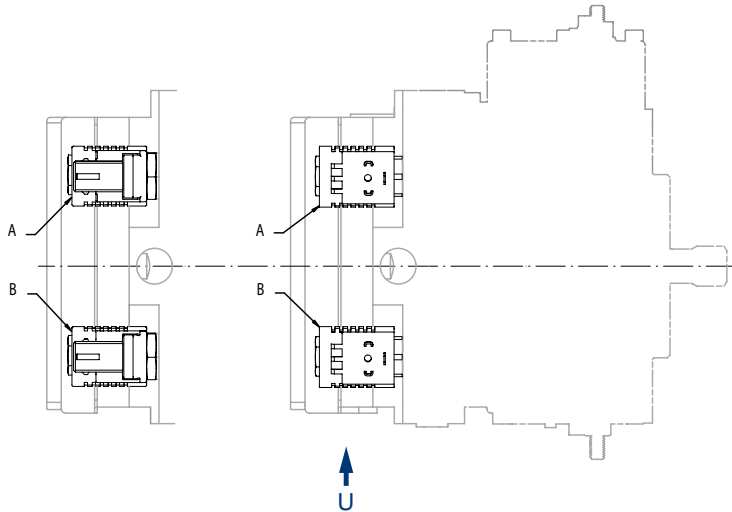

**TOP VIEW**  
**VARIABLE PUMP W/ FNR CONTROL**

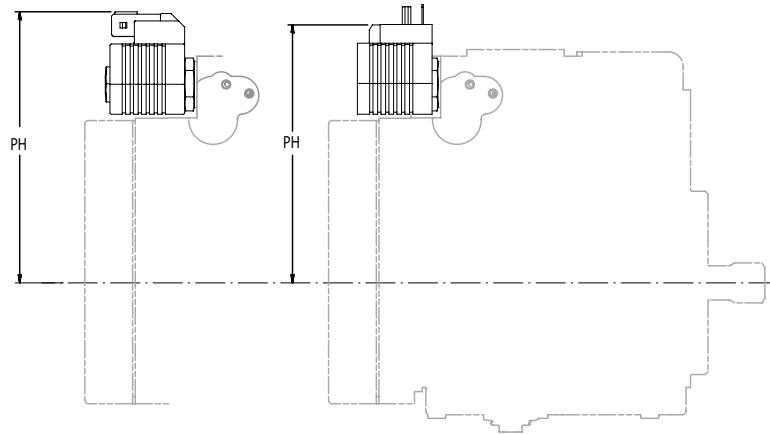

**OPTION F**  
**STYLE 8**

**OPTION F**  
**STYLE 6&7**

**VIEW U**  
**(LEFT SIDE VIEW)**

P100432E

*Forward neutral reverse control dimensions*

Frame size	Style	PH
28/32	Style 6 & 7	143.2 [5.64]
	Style 8	150.3 [5.92]

*Pump flow direction with FNR control*

Input shaft rotation	CW		CCW	
	A	B	A	B
Solenoid energized	A	B	A	B
Port A flow	Out	In	In	Out
Port B flow	In	Out	Out	In
High pressure servo gage port	M4	M5	M4	M5





**CONTROL MODULES**  
 (continued)

**Three-position electric control (FNR) options**

**FRAME SIZE 41/51**

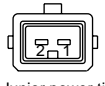

AMP Junior power timer\*  
 2 pin connector  
 (male terminals)

Sauer-Danfoss  
 mating parts kit  
 No. K508388  
 (female terminal)

**FNR CONNECTORS**

\* Special temperature requirements,  
 see your Sauer-Danfoss  
 representative when considering  
 this option

P100434E

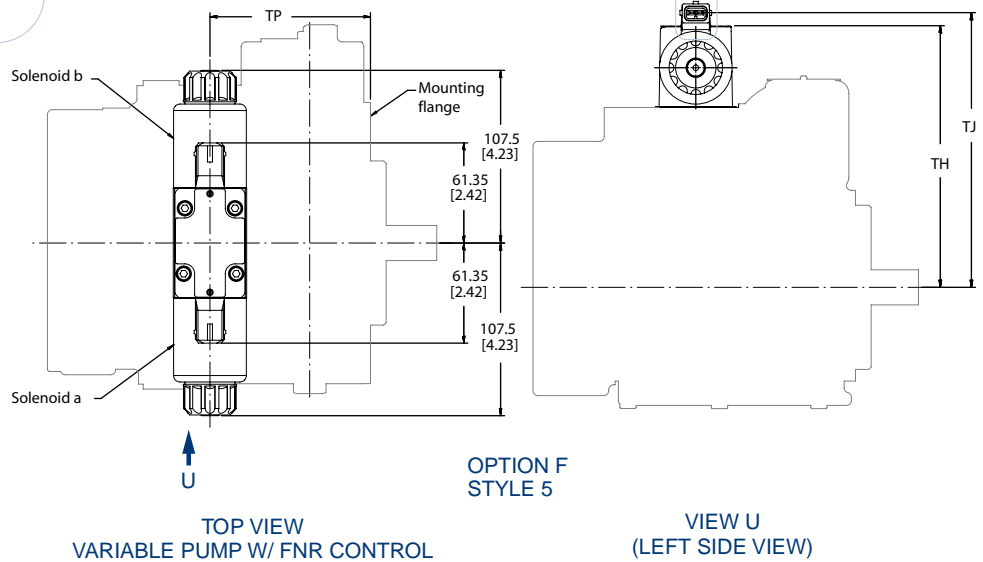

*Forward neutral reverse control dimensions*

Frame size	TP	TH	TJ
41/51	111.2 [4.38]	177.3 [6.98]	186.8 [7.35]

*Pump flow direction with NFPE control*

Input shaft rotation	CW		CCW	
	a	b	a	b
Solenoid energized	a	b	a	b
Port A flow	Out	In	In	Out
Port B flow	In	Out	Out	In
High pressure servo gauge port	M4	M5	M4	M5



**CONTROL MODULES**  
 (continued)

**Three-position electric control (FNR) options**

**FRAME SIZE 41/51**

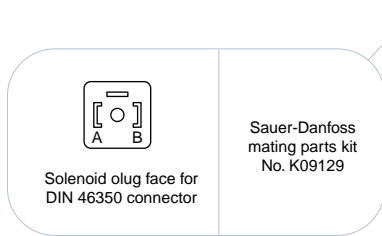
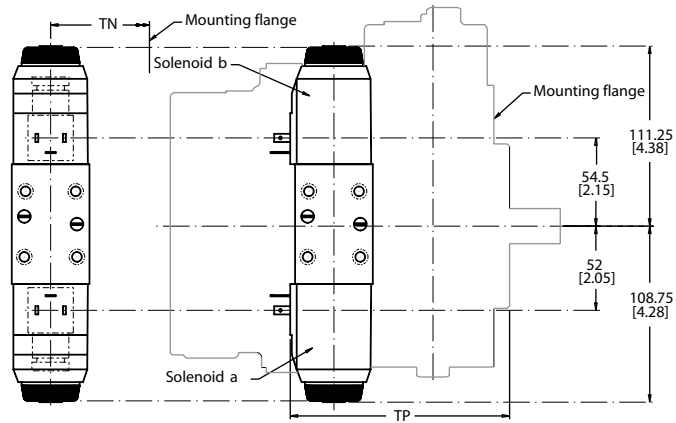

**FNR CONNECTORS**

\* Special temperature requirements, see your Sauer-Danfoss representative when considering this option

P100426E

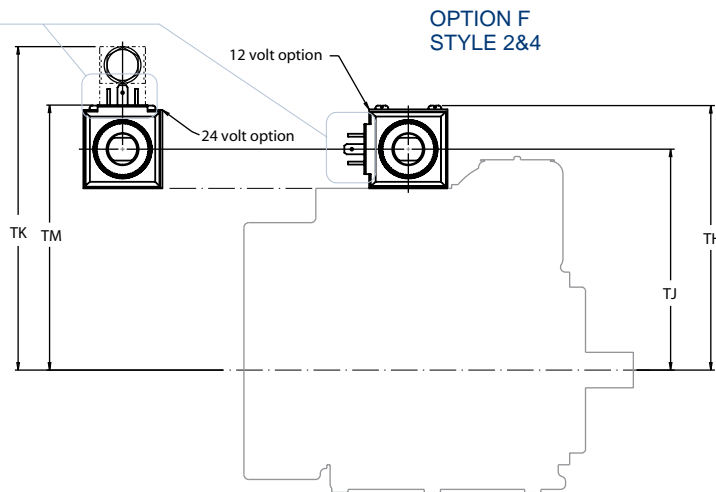

**OPTION F  
 STYLE 2&4**

*Forward neutral reverse control dimensions, 12 volt option*

Frame size	TP	TH	TJ
41/51	138.2 [5.44]	179.6 [7.07]	152.9 [6.02]

*Forward neutral reverse control dimensions, 24 volt option*

Frame size	TJ	TK	TM	TN
41/51	152.9 [6.02]	215.7 [8.49]	179.9 [7.08]	106.5 [4.19]

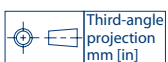

Third-angle projection  
 mm [in]

**CONTROL MODULES**  
 (continued)

**Non-feedback proportional hydraulic (NFPH) control options**

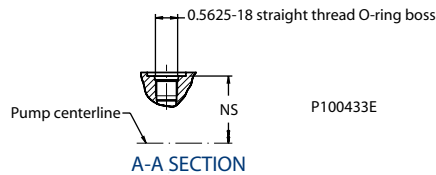
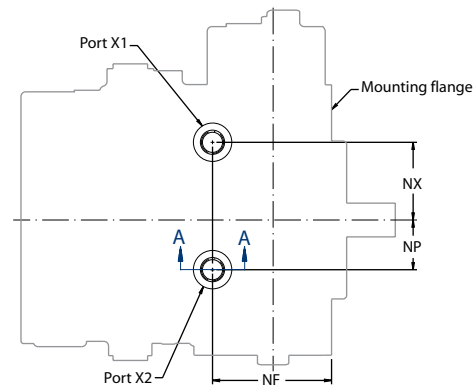

*Non-feedback proportional hydraulic control dimensions*

Frame size	NF	NS	NP	NX
28/32	76.6 [3.02]	111.3 [4.38]	33 [1.30]	46 [1.81]
41/51	88 [3.46]	128.3 [5.05]	31 [1.22]	54 [2.13]

\*All SAE straight thread O-ring ports per SAE J1926/ISO 11926-1, unless otherwise specified.

Determine rotation by viewing pump from the input shaft end. Contact your Sauer-Danfoss representative for specific installation drawings.



**CONTROL MODULES**  
 (continued)

**Non-feedback proportional electric (NFPE) control options**

**FRAME SIZE 28/32**

Dimensions: mm [in]

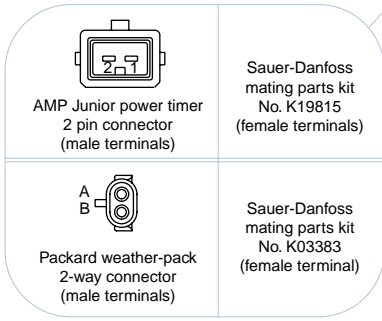

NFPE CONNECTOR

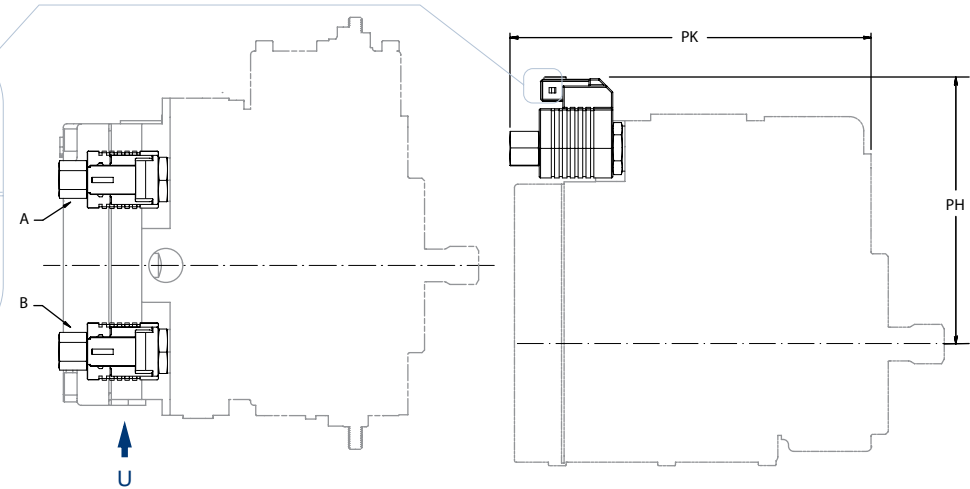

TOP VIEW  
 VARIABLE PUMP W/ NFPE CONTROL

VIEW U  
 (LEFT SIDE VIEW)

*Manifold height*

Frame Size	PH	PK
28/32 (AMP Jr Power Timer)	150.7 [5.93]	203.4 [8.00]
28/32 (Packard Weather-Pack)	144.6 [5.69]	203.4 [8.00]

**Non-feedback proportional electric (NFPE) control options**

**FRAME SIZE 41/51**

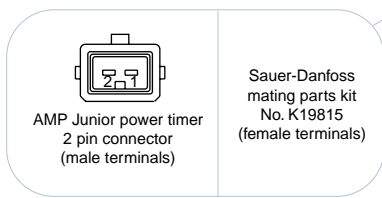

NFPE CONNECTOR

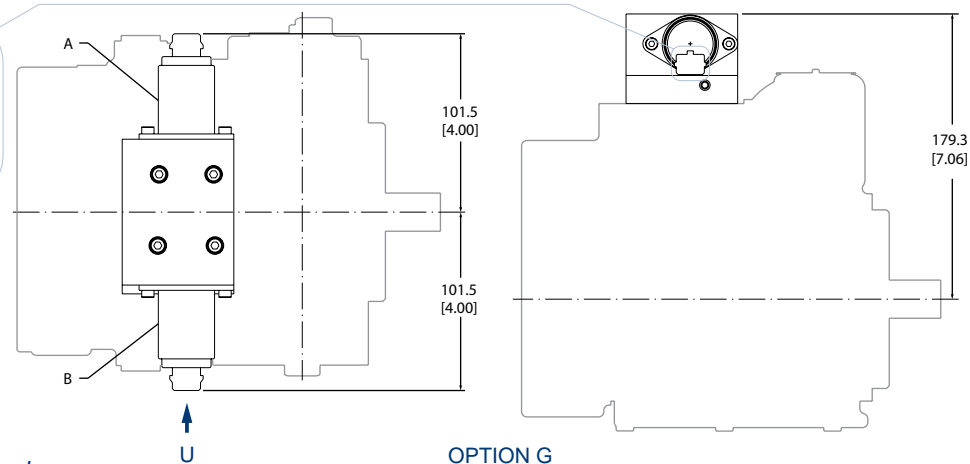

TOP VIEW  
 VARIABLE PUMP W/ NFPE CONTROL

VIEW U  
 (LEFT SIDE VIEW)

*Pump flow direction with NFPE control*

Input shaft rotation	CW		CCW	
	A	B	A	B
Solenoid energized	A	B	A	B
Port A flow	Out	In	In	Out
Port B flow	In	Out	Out	In
High pressure servo gage port	M4	M5	M4	M5

P100435E



**CONTROL MODULES**  
 (continued)

**Electrical displacement control (HC-EDC) options**

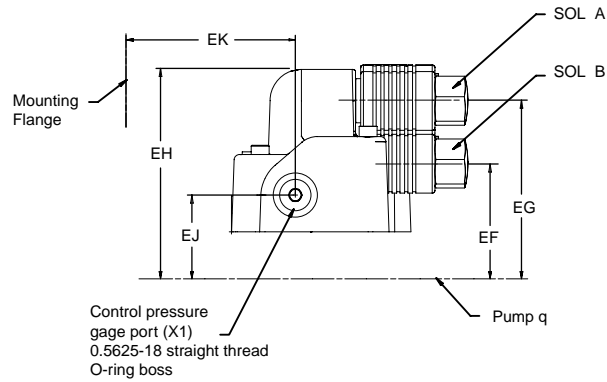

VIEW V  
 RIGHT SIDE VIEW

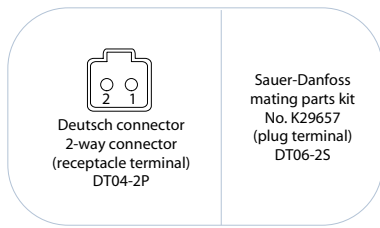

HC-EDC CONNECTOR

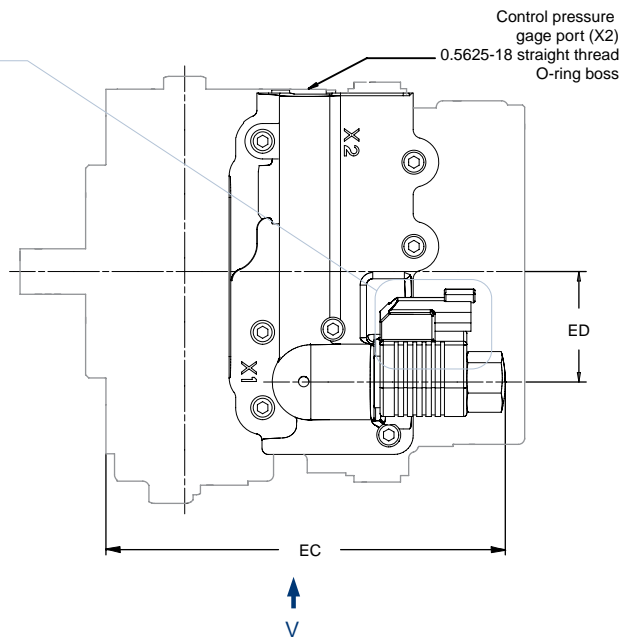

OPTION E2  
 HIGH CURRENT DISPLACEMENT CONTROL

*Electrical displacement control dimensions*

Frame size	EC	ED	EF	EG	EH	EJ	EK
28/32	190.6 [7.5]	52.7 [2.08]	157.0 [6.18]	189.5 [7.46]	196.5 [7.74]	132.6 [5.22]	94.4 [3.72]
41/51	200.6 [7.9]	52.7 [2.08]	174.0 [6.85]	206.6 [8.13]	213.5 [8.41]	149.6 [5.89]	104.6 [4.12]

\*All SAE straight thread O-ring ports per SAE J1926/ISO 11926-1, unless otherwise specified.



**CONTROL MODULES**  
 (continued)

**Electrical displacement control (EDC) options**

<p>Packard weather-pack 4-way connector (male terminals)</p>	<p>Sauer-Danfoss mating parts kit No. K03384 (female terminal)</p>
<p>MS connector MS3102C-14S-2P</p>	<p>Sauer-Danfoss mating parts kit No. K08106 (plug terminal)</p>
<p>Deutsch connector 4-way connector (receptacle terminal) DT04-4P</p>	<p>Sauer-Danfoss mating parts kit No. K23511 (plug terminals) DT06-4S</p>

EDC CONNECTORS

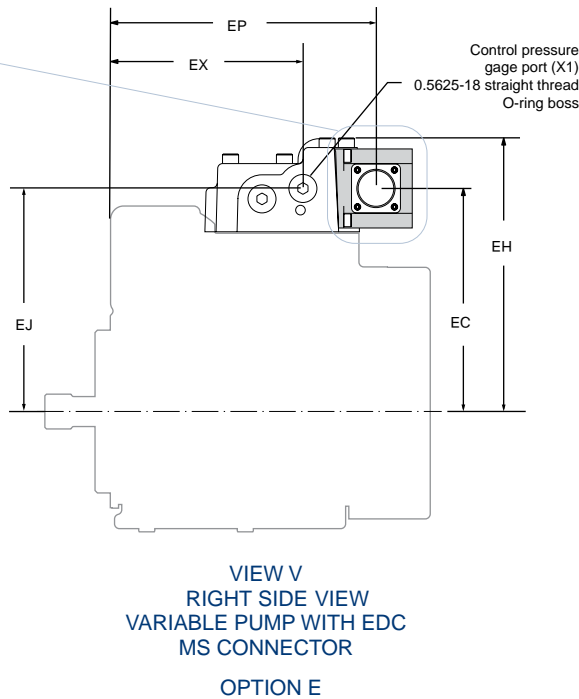
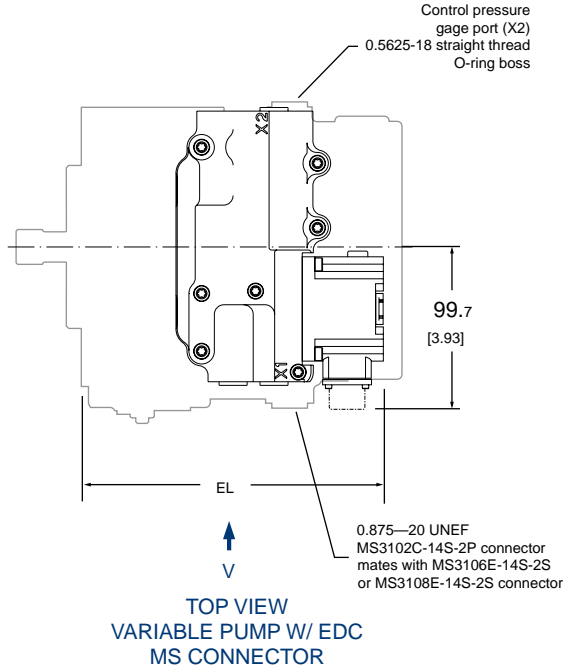

*Electrical displacement control dimensions*

Frame size	EC	EH	EJ	EL	EP	EX
28/32	138.7 [5.46]	170.2 [6.70]	138.7 [5.46]	188 [7.40]	165.7 [6.52]	119.9 [4.72]
41/51	155.7 [6.13]	187.2 [7.37]	155.7 [6.13]	198 [7.80]	175.7 [6.92]	129.9 [5.11]

\*All SAE straight thread O-ring ports per SAE J1926/ISO 11926-1, unless otherwise specified.



**SPEED SENSOR OPTION**

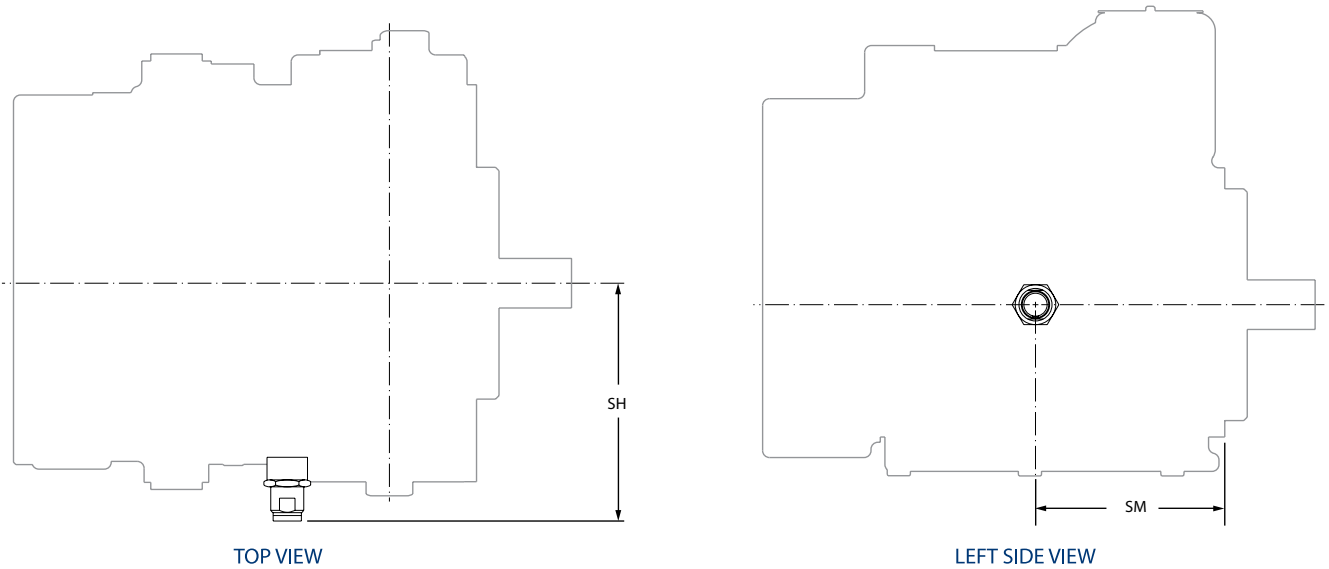

P100427E

*Speed sensor height*

Frame size	SH	SM
28/32	104.24 [4.1]	81.7 [3.22]
41/51	107.84 [4.25]	89.35 [3.52]

*Speed sensor with Packard Weather-Pack connector (KPPG13408)*

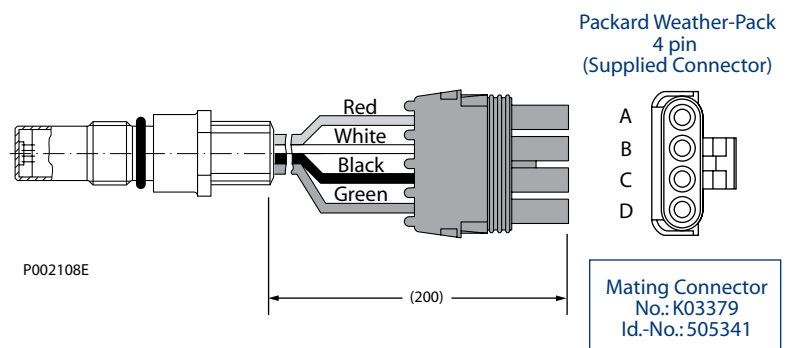

**AUXILIARY MOUNTING  
 PADS**



SAE A (OPTION A, OPTION T, OPTION R)

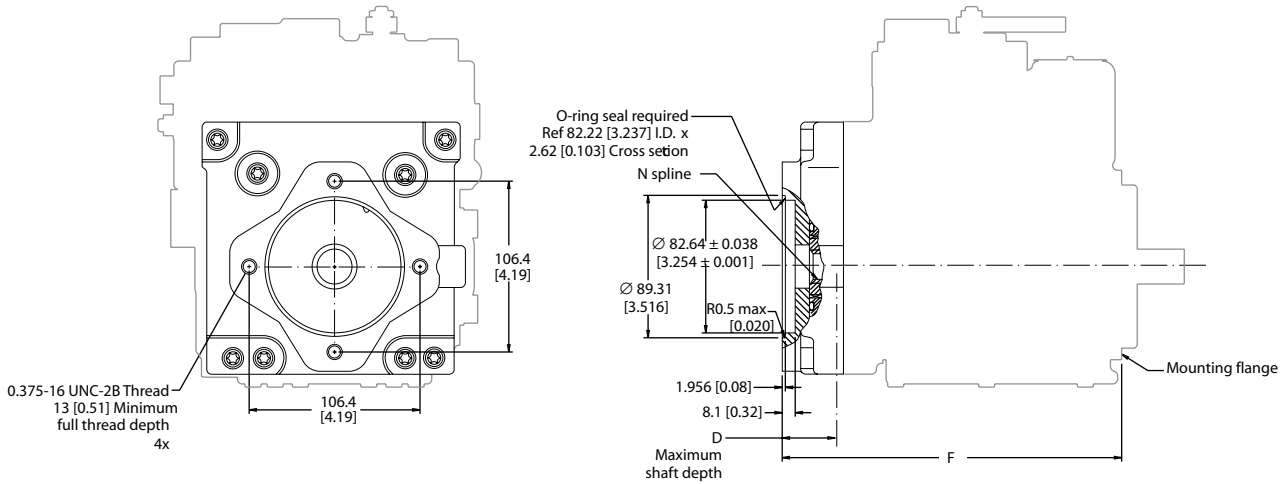

SAE B (OPTION B, OPTION V)

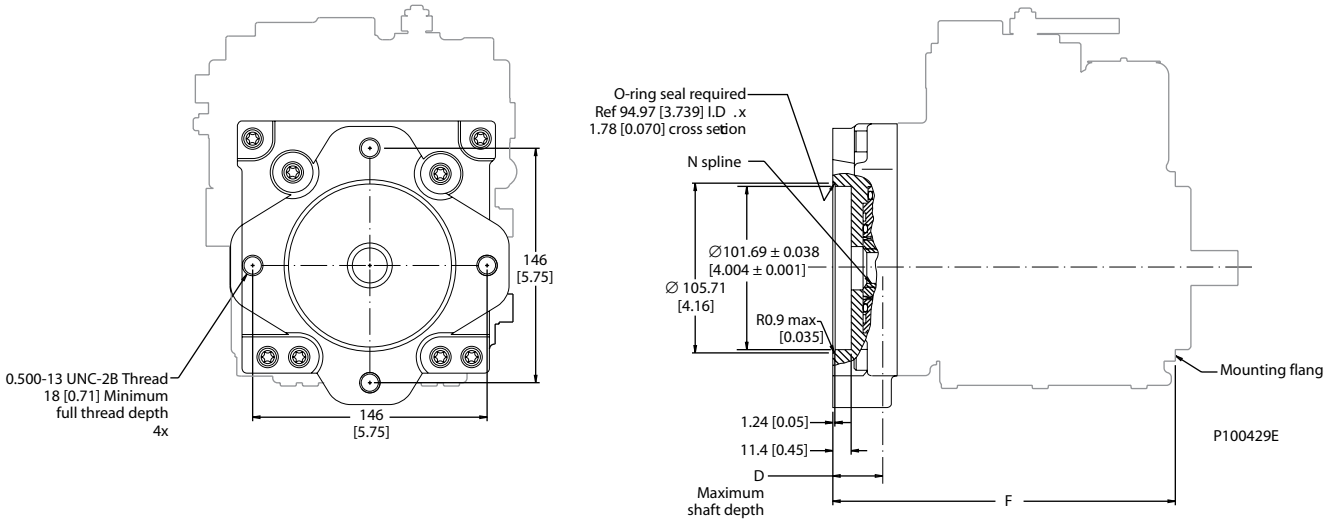

\*All SAE straight thread O-ring ports per SAE J1926/ISO 11926-1, unless otherwise specified.

Determine rotation by viewing pump from the input shaft end. Contact your Sauer-Danfoss representative for specific installation drawings.

*Auxiliary mounting flange and coupling options*

Auxiliary mounting flange	Spline pitch diameter P	Number of teeth N	Dimension D		Dimension F	
			28 cm <sup>3</sup>	41/51 cm <sup>3</sup>	28 cm <sup>3</sup>	41/51 cm <sup>3</sup>
Option A	14.288 [0.563]	9	44 [1.73]	44 [1.73]	211.59 [8.33]	230.89 [9.09]
Option T	17.463 [0.688]	11	44 [1.73]	44 [1.73]	211.59 [8.33]	230.89 [9.09]
Option B	20.638 [0.813]	13	46 [1.81]	46 [1.81]	213.3 [8.40]	232.6 [9.16]
Option V	23.813 [0.9375]	15	46 [1.81]	46 [1.81]	213.3 [8.40]	232.6 [9.16]
Option R	20.638 [0.813]	13	-	46 [1.81]	-	230.89 [9.09]



**PUMP SCHEMATICS**

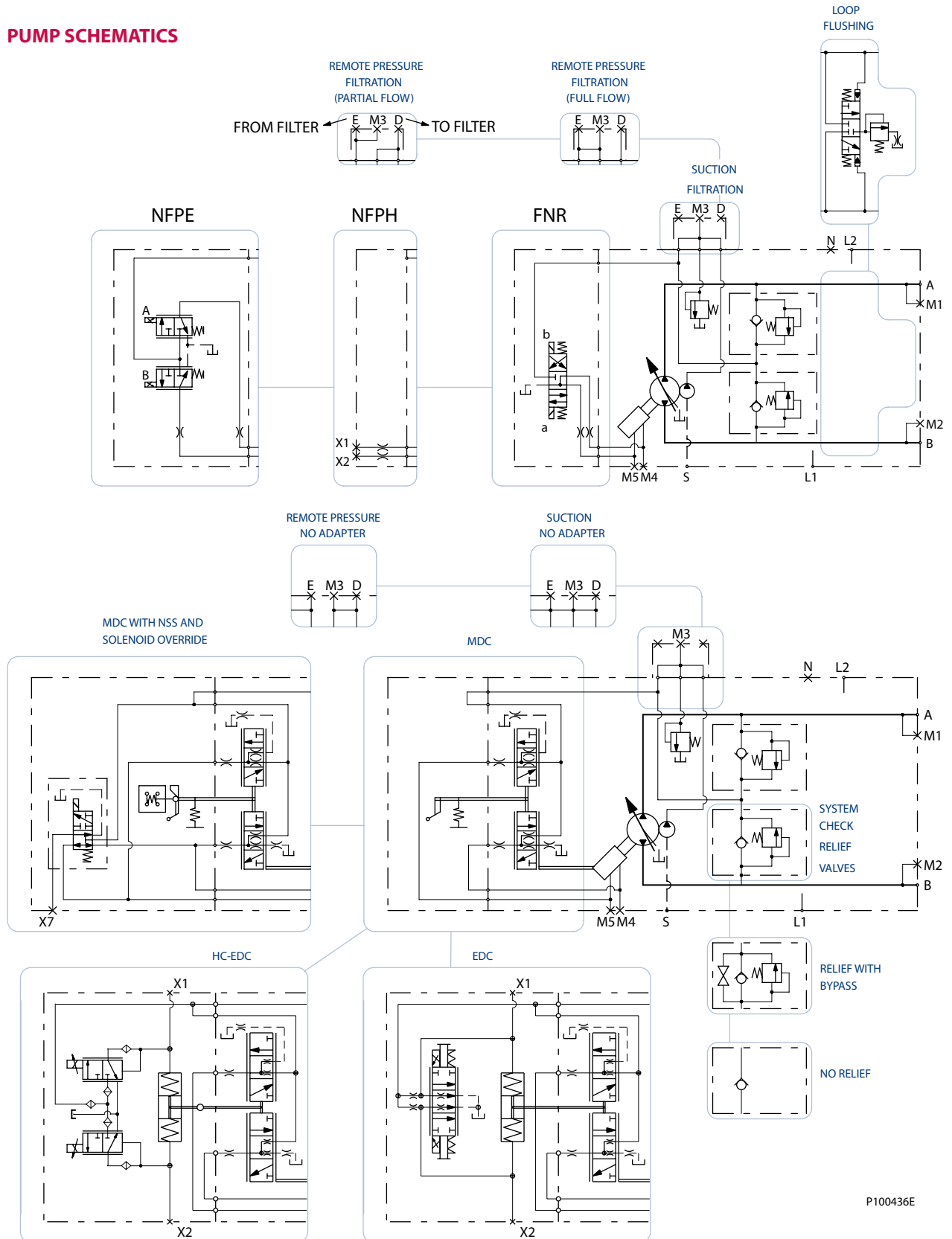

P100436E

**PUMP MODEL CODE**

**A B Y C D E F Q R G S T U H J K L M N P**  
 4 2

Legend:  
 ● = Standard  
 ○ = Optional  
 - = Not Available

**A Product series**

Code	Description
A	Series 42

**B Rotation**

Code	Description	28	32	41	51
L	Pump, left hand rotation (CCW)	●	●	●	●
R	Pump, right hand rotation (CW)	●	●	●	●

**Y Displacement**

Code	cm <sup>3</sup> /rev [in <sup>3</sup> /rev]	28	32	41	51
28	28 cm <sup>3</sup> /rev (1.71 CU.IN.) without speed sensing	●	-	-	-
2A	28 cm <sup>3</sup> /rev (1.71 CU.IN.) with speed sensing	○	-	-	-
3Y	31.8 cm <sup>3</sup> /rev (1.94 CU.IN) without speed sensing	-	●	-	-
41	41 cm <sup>3</sup> /rev (2.50 CU.IN.) without speed sensing	-	-	●	-
4A	41 cm <sup>3</sup> /rev (2.50 CU.IN.) with speed sensing	-	-	○	-
51	51 cm <sup>3</sup> /rev (3.11 CU.IN.) without speed sensing	-	-	-	●
5A	51 cm <sup>3</sup> /rev (3.11 CU.IN.) with speed sensing	-	-	-	○

**C Input Shaft Configuration**

Code	Description	28	32	41	51
C	13 teeth 16/32 pitch	●	●	○	○
D	15 teeth 16/32 pitch	○	○	●	●
E	19 teeth 16/32 pitch	-	-	○	○
G	1.0 inch round straight keyed	○	○	○	○
K	Tapered shaft with key **	-	-	○	○

---

\*\* Not recommended for all options.

---

**PUMP MODEL CODE**  
 (continued)



Legend:	
●	= Standard
○	= Optional
-	= Not Available

**D Control Type**

Control	Description		
No Control (Cover Plate): <b>N</b> = None (MDC/EDC) <b>M</b> = None (NFPE/FNR)	<b>D</b> = Shipping Cover	<b>N</b> = N/A	<b>N</b> = N/A
Manual Displacement: <b>A</b> = MDC, Standard <b>L</b> = MDC, NAR Deadband	Neutral Start Switch: <b>N</b> =None	Override to Neutral: <b>N</b> =None	Other Features: <b>3</b> =Std handle with low gain spool <b>5</b> =Clevis handle with high gain <b>A</b> =Clevis handle with low gain spool <b>B</b> =Std handle with high gain (Standard)
	NSS (only) <b>1</b> =Weather <b>2</b> =Term	Override to Neutral with Brake Release:	
	NSS+BAS with CW handle rotation: <b>3</b> =Weather <b>4</b> =Leads <b>7</b> =Deutsch	Internal SOL <b>A</b> =12V, Weather <b>B</b> =12V, DIN <b>C</b> =24V, Weather <b>D</b> =24V, DIN <b>J</b> =12V, Deutsch <b>K</b> =24V, Deutsch	
	NSS+BAS with CCW handle rotation <b>5</b> =Weather <b>6</b> =Leads <b>8</b> =Deutsch		

Electrical displacement: <b>E</b> =EDC, HC-EDC	Style: <b>1</b> =PCP style	Input: <b>A</b> =14-85 MA	Connector/spool: <b>3</b> =Weather, low gain spool <b>4</b> =MS, low gain spool <b>5</b> =Weather, high gain spool <b>6</b> =MS, high gain spool <b>7</b> =Deutsch, high gain spool
	<b>2</b> =Dual solenoid High current displacement control	<b>C</b> =12V 300-750 mA <b>D</b> =24V 150-375mA	<b>7</b> =Deutsch with lead wire(special), high gain <b>8</b> =Deutsch ,high gain

3-Position FNR: <b>F</b> =FNR	Style: <b>2</b> =Bolt-on, 12 V, DIN (41/51cc only) <b>4</b> =Bolt-on, 24 V, DIN (41/51cc only) <b>5</b> =Bolt-on, 12 V, Amp Jr (41/51cc only) <b>6</b> =Integral, 12 V DIN (28/32cc only) <b>7</b> =Integral, 24V DIN (28/32cc only) <b>8</b> =Integral, 12 V, Amp Jr (28/32cc only)	<b>N</b> =None	<b>N</b> =None
----------------------------------	--	----------------	----------------

Non-feedback proportional <b>G</b> =NFP	Style: <b>1</b> =Electric - 12 V (Bolt-On) (41/51cc only) <b>2</b> =Electric - 12 V (Integral) (28/32cc only)	Input: <b>A</b> =650-1000 MA, 5-20 BAR	Connector: <b>1</b> =Amp Jr Power Timer <b>2</b> =Packard Weather-Pack (28/32cc only)
	<b>3</b> =Hydraulic style	<b>A</b> =5-20 BAR	<b>N</b> =N/A

**PUMP MODEL CODE  
 (continued)**

**A B Y C D E F Q R G S T U H J K L M N P**  
 4 2

Legend:  
 ● = Standard  
 ○ = Optional  
 - = Not Available

**E Control Response Time**

Control	Description	28	32	41	51
<b>MDC, EDC:</b>	<b>Servo A, drain A, drain B, servo B (Gasket Orifice)</b>				
<b>00</b>	Gasket without orifice	○	○	○	○
<b>01</b>	FAST, (1.6, 1.6, 1.6, 1.6)	○	○	○	○
<b>02</b>	Medium (1.0, 4.0, 4.0, 1.0 mm)	○	○	○	○
<b>03</b>	Slow (Standard) (0.8, 4.0, 4.0, 0.8 mm)	●	●	●	●

Control	Description	28	32	41	51
<b>NFPH, Integral NFPE, (28/32/41/51 cc) &amp; Integral FNR Options(28/32cc only):</b>	<b>Servos A and B (Plug Orifice)</b>				
<b>50</b>	No Orifice (Standard)	●	●	●	●
<b>52</b>	Medium 1.0 mm	○	○	○	○
<b>53</b>	Slow 0.8 mm	○	○	○	○

Control	Description	28	32	41	51
<b>Bolt-on FNR &amp; Bolt-on NFPE Options:</b>	<b>Servos A and B (Plug Orifice)</b>				
<b>70</b>	No Orifice	-	-	○	○
<b>72</b>	Medium 1.0 mm	-	-	●	●
<b>73</b>	Slow 0.8 mm	-	-	○	○

**F, Q, R Port/housing style, Loop Flushing, Filtration**

Frame size	F: Port Style/Housing	Q: Loop Flushing/Cooling	R: Filtration
<b>28/32</b>	<b>MDC, EDC (All feedback controls)</b>		
	<b>A</b> =SAE Threaded O-ring Boss (No loop flushing, no filter pad, base housing)	<b>N</b> =None	<b>N</b> =None (External charge supply, No Adapter) <b>A</b> =Suction, No Adapter
	<b>B</b> =SAE Threaded O-ring Boss (Required for speed ring or sensor full featured housing)	<b>D</b> =Defeated loop flushing <b>2</b> =Loop flush/cool <b>3</b> =Loop flush/cool <b>4</b> =Loop flush/cool <b>5</b> =Loop flush/cool <i>Please refer to page 22. Loop flushing flow</i>	<b>B</b> =Remote Pressure (Full flow) with adapter
	<b>C</b> =SAE Threaded O-ring Boss (Loop flushing, no filter pad-base housing)	<b>D</b> =Defeated loop flushing <b>2</b> =Loop flush/cool <b>3</b> =Loop flush/cool <b>4</b> =Loop flush/cool <b>5</b> =Loop flush/cool <i>Please refer to page 22. Loop flushing flow</i>	<b>N</b> =None (External charge supply, no adapter) <b>A</b> =Suction, no adapter
	<b>D</b> =SAE Threaded O-ring boss (No loop flushing, integral full flow filtration)	<b>N</b> =None	<b>F</b> =Remote pressure (Full Flow), without adapter

**PUMP MODEL CODE**  
 (continued)



Legend:	
●	= Standard
○	= Optional
-	= Not Available

**F, Q, R** *Port/housing style, Loop Flushing, Filtration*

Frame Size	F: Port Style/Housing	Q: Loop FLushing/Cooling	R: Filtration
28/32	<b>NFPE &amp; FNR</b> (Integral non-feedback proportional electric and 3 position controls)		
	<b>U</b> =SAE Threaded O-ring boss (Required for speed ring and sensor-full featured housing)	<b>D</b> =Defeated loop flushing <b>2</b> =Loop flush/cool <b>3</b> =Loop flush/cool <b>4</b> =Loop flush/cool <b>5</b> =Loop flush/cool <small>Please refer to page 22. Loop flushing flow</small>	<b>X</b> =None (external charge supply, with adapter) <b>G</b> =Suction, with adapter <b>B</b> =Remote pressure (Full flow), with adapter
	<b>V</b> =SAE Threaded O-ring boss (No Loop Flushing, Integral Full Flow Filtration, Not for use with speed sensor)	<b>N</b> =None	<b>F</b> =Remote pressure (Full flow), without adapter

28/32	<b>NFPH</b> (Non-feedback proportional hydraulic)		
	<b>T</b> =SAE Threaded O-ring Boss (No loop flushing, no filter pad-base housing)	<b>N</b> =None	<b>D</b> =Suction, No Adapter, No gauge port plug <b>M</b> =None (External charge special, no gauge port plug)
	<b>P</b> =SAE Threaded O-ring Boss (Required for speed ring or sensor-full featured housing)	<b>D</b> =Defeated loop flushing <b>2</b> =Loop flush/cool <b>3</b> =Loop flush/cool <b>4</b> =Loop flush/cool <b>5</b> =Loop flush/cool <small>Please refer to page 22. Loop flushing flow</small>	<b>X</b> =None (external charge supply, with adapter) <b>G</b> =Suction, with adapter <b>B</b> =Remote pressure (full flow), with adapter

41/51	<b>MDC</b> (All feedback controls)		
	<b>A</b> =SAE threaded O-ring boss (No loop flushing, no filter pad housing)	<b>N</b> =None	<b>N</b> =None (External charge supply, no adapter) <b>A</b> =Suction, no adapter
	<b>B</b> =SAE threaded O-ring boss (Required for speed ring or sensor-full featured housing)	<b>D</b> =Defeated loop flushing <b>2</b> =Loop flush/cool <b>3</b> =Loop flush/cool <b>4</b> =Loop flush/cool <b>5</b> =Loop flush/cool <small>Please refer to page 22. Loop flushing flow</small>	<b>B</b> =Remote pressure (Full flow), with adapter
	<b>C</b> =SAE threaded O-ring boss (Loop flushing, no filter pad-base housing)	<b>D</b> =Defeated loop flushing <b>2</b> =Loop flush/cool <b>3</b> =Loop flush/cool <b>4</b> =Loop flush/cool <b>5</b> =Loop flush/cool <small>Please refer to page 22. Loop flushing flow</small>	<b>N</b> =None (External charge supply, no adapter) <b>A</b> =Suction, no adapter
	<b>D</b> =SAE threaded O-ring boss (No loop flushing, integral full flow filtration)	<b>N</b> =None	<b>F</b> =Remote pressure (Full flow), without adapter



**PUMP MODEL CODE**  
 (continued)



Frame Size	G: Charge/Implement Pump	S: Charge Relief Setting	T: Special Drive Features	U: Rear Auxiliary Mounting Pad
<b>28/32 and 41/51</b>	<p><b>A</b>=None (with no coupling, auxiliary pad options Y &amp; Z)</p> <p><b>N</b>=None (w/spacer - not available for rear auxiliary mounting pad option N)</p> <p><b>2</b>=11cc</p> <p><b>3</b>=15.6cc</p>	<p><b>A</b>= 10 bar (145 psi)</p> <p><b>B</b>=12 bar (174 psi)</p> <p><b>C</b>=14 bar (203 psi)</p> <p><b>D</b>=16 bar (232 psi)</p> <p><b>E</b>=18bar (261psi)</p> <p><b>F</b>=20 bar (290 psi)</p> <p><b>G</b>=22 bar (319 psi)</p> <p><b>H</b>=24 bar (348 psi)</p> <p><b>P</b>=Defeated</p>	<p><b>N</b>=None</p> <p><b>1</b>=NFP with anti-stall</p> <p><b>5</b>=NFP with standard CRPV</p>	<p><b>N</b>=None, with charge pump (Not for use with Charge pump option = N)</p> <p><b>A</b>=SAE-A, 9 tooth</p> <p><b>B</b>=SAE-B, 13 tooth</p> <p><b>T</b>=SAE-A special, 11 tooth</p> <p><b>R</b>=SAE A, 13 tooth (41/51cc only)</p> <p><b>V</b>=SAE B-B, 15 tooth</p> <p><b>Z</b>=None (With external charge, charge pump option A)</p>

**PUMP MODEL CODE**  
 (continued)

A B Y C D E F Q R G S T U H J K L M N P  
 4 2

Legend:	
●	= Standard
○	= Optional
-	= Not Available

**H System Pressure Protection-Port A**

Code	Description	28	32	41	51
NN	None (Check valve only)	○	○	○	○
14	140 bar (2030 psi) HPRV	○	○	○	○
17	175 bar (2540 psi) HPRV	○	○	○	○
19	190 bar (2755 psi) HPRV	○	○	○	○
21	210 bar (3045 psi) HPRV	○	○	○	○
23	230 bar (3330 psi) HPRV	○	○	○	○
25	250 bar (3335 psi) HPRV	○	○	○	○
28	280 bar (4060 psi) HPRV	○	○	○	○
30	300 bar (4350 psi) HPRV	○	○	○	○
32	325 bar (4715 psi) HPRV	○	○	○	○
34	345 bar (5000 psi) HPRV	○	○	○	○
36	360 bar (5220 psi) HPRV	○	-	○	-
38	385 bar (5580 psi) HPRV	○	-	○	-
41	415 bar (6020 psi) HPRV	○	-	○	-
00	No check valve, no HPRV	○	-	○	-

A B Y C D E F Q R G S T U H J K L M N P  
 4 2

**J System Pressure Protection-Port B**

Code	Description	28	32	41	51
NN	None (Check valve only)	○	○	○	○
14	140 bar (2030 psi) HPRV	○	○	○	○
17	175 bar (2540 psi) HPRV	○	○	○	○
19	190 bar (2755 psi) HPRV	○	○	○	○
21	210 bar (3045 psi) HPRV	○	○	○	○
23	230 bar (3330 psi) HPRV	○	○	○	○
25	250 bar (3335 psi) HPRV	○	○	○	○
28	280 bar (4060 psi) HPRV	○	○	○	○
30	300 bar (4350 psi) HPRV	○	○	○	○
32	325 bar (4715 psi) HPRV	○	○	○	○
34	345 bar (5000 psi) HPRV	○	○	○	○
36	360 bar (5220 psi) HPRV	○	-	○	-
38	385 bar (5580 psi) HPRV	○	-	○	-
41	415 bar (6020 psi) HPRV	○	-	○	-
00	No check valve, no HPRV	○	-	○	-



**PUMP MODEL CODE**  
 (continued)

A B Y C D E F Q R G S T U H J K L M N P  
 4 2

Legend:

- = Standard
- = Optional
- = Not Available

**K Loop bypass valve**

Code	Description	28	32	41	51
N	None	●	●	●	●
B	Bypass Valve	○	○	○	○

**L Displacement limiters - side 1**

Code	Description	28	32	41	51
N	None	●	●	●	●
A	Adjustable limiter set at max. displacement	○	○	○	○
<b>Displacement limiters - NFP, Side 1</b>					
0	None	●	●	●	●
1	Adjustable limiter set at max displacement	○	○	○	○

**M Displacement Limiters - Side 2**

Code	Description	28	32	41	51
N	None	●	●	●	●
A	Adjustable limiter set at max. displacement	○	○	○	○
<b>Displacement limiters - NFP, Side 2</b>					
0	None	●	●	●	●
1	Adjustable limiter set at max. displacement	○	○	○	○

**N Special hardware**

Code	Description	28	32	41	51
NNN	None	●	●	●	●
AAA	Speed sensor with weather packard connector	○	○	○	○

**P Special features**

Code	Description	28	32	41	51
NNN	None	●	●	●	●



Series 42 Axial Piston Pumps  
Technical Information  
Notes



Series 42 Axial Piston Pumps  
Technical Information  
Notes



## Our Products

Open circuit axial piston pumps  
Gear pumps and motors  
Fan drive systems  
Closed circuit axial piston pumps and motors  
Bent axis motors  
Hydrostatic transmissions  
Transit mixer drives  
Hydrostatic transaxles  
Electrohydraulics  
Integrated systems  
Microcontrollers and software  
PLUS+1™ GUIDE  
Displays  
Joysticks and control handles  
Sensors  
Orbital motors  
Inverters  
Electrohydraulic power steering  
Hydraulic power steering  
Hydraulic integrated circuits (HIC)  
Cartridge valves  
Directional spool valves  
Proportional valves

## SAUER-DANFOSS MOBILE POWER AND CONTROL SYSTEMS – MARKET LEADERS WORLDWIDE

Sauer-Danfoss is a comprehensive supplier providing complete systems to the global mobile market.

Sauer-Danfoss serves markets such as agriculture, construction, road building, material handling, municipal, forestry, turf care, and many others.

We offer our customers optimum solutions for their needs and develop new products and systems in close cooperation and partnership with them.

Sauer-Danfoss specializes in integrating a full range of system components to provide vehicle designers with the most advanced total system design.

Sauer-Danfoss provides comprehensive worldwide service for its products through an extensive network of Global Service Partners strategically located in all parts of the world.

Local address:

Sauer-Danfoss (US) Company  
2800 East 13th Street  
Ames, IA 50010, USA  
Phone: +1 515 239-6000  
Fax: +1 515 239 6618

Sauer-Danfoss GmbH & Co. OHG  
Postfach 2460, D-24531 Neumünster  
Krokamp 35, D-24539 Neumünster, Germany  
Phone: +49 4321 871-0  
Fax: +49 4321 871 122

Sauer-Danfoss ApS  
DK-6430 Nordborg, Denmark  
Phone: +45 7488 4444  
Fax: +45 7488 4400

Sauer-Danfoss-Daikin LTD.  
Shin-Osaka TERASAKI 3rd Bldg. 6F  
1-5-28 Nishimiyahara, Yodogawa-ku  
Osaka 532-0004, Japan  
Phone: +81 6 6395 6066  
Fax: +81 6 6395 8585