

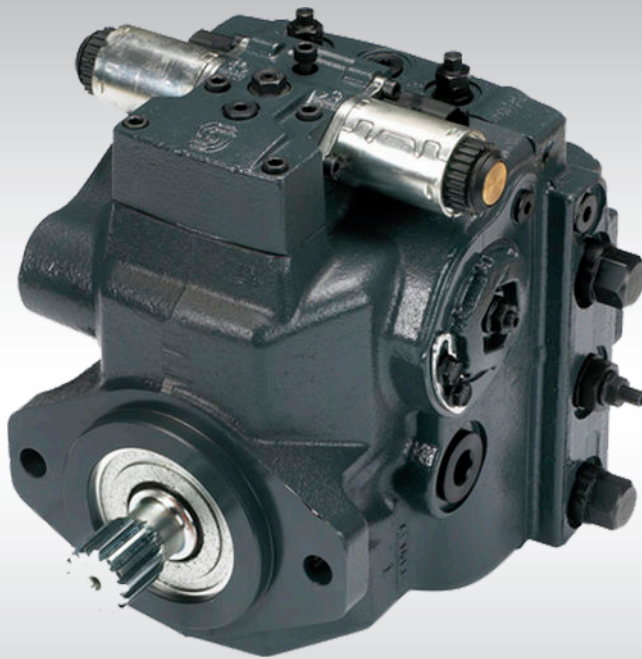

Technical Information
Automotive on PLUS+1[®]
for MC-024

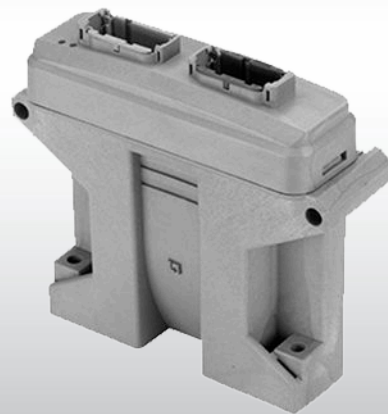

PLUS 



Revision history*Table of revisions*

Date	Changed	Rev
Dec 2015	Converted to DITA CMS and Danfoss layout	0201
Mar 2012	Typos	0102
Dec 2011	First edition	0101

Contents
General Information

General Description, Electric and Electronics.....	4
Automotive-on PLUS+1 (AoP+1), system description.....	4
Automotive on PLUS+1 advanced functions.....	4
Required Controller.....	4
Mode Types.....	5
Hydrostatic propel methods.....	5
Automotive Mode.....	6
Non-Automotive Mode.....	7
Creep-Automotive Mode.....	8
System modes and selection.....	9
Application Function.....	10
General customer / sensor requirements.....	13
Drive / Creep / Joystick / Rocker and inch pedal.....	13
Pressure inch sensor.....	13
Mode switch A.....	14
Mode switch B.....	14
HST / Motor / PPU.....	14
Pump displacement.....	14
Motor displacement and Brake Pressure defeat (BPD)	14
Digital outputs 1, 2, 3, 4.....	14
Automotive Control connection diagram.....	15

Technical Specifications

Input signals: Power supply – Battery.....	16
Input signals: Forward-Neutral-Reverse (FNR) switch.....	17
Input signals: Mode switch.....	18
Input signals: Inch pedal.....	19
Input signals: Drive/Creep pedal, Joystick and Rocker pedal	20
Input signals: Motor speed sensor	21
Output signals: Pump displacement control.....	22
Output signals: Motor displacement and Brake Pressure Defeat (BPD) control.....	23
Output signals: Digital outputs 1, 2, 3, 4.....	24
CAN Communication: Input and Output signals.....	25
Mating Connectors.....	26
Customer connector: 1, 2 (C1, C2).....	26
CAN Bus adapter cable.....	27
AC Electrical Data & Characteristics.....	27
Supply characteristics.....	27
I/O characteristics.....	28
Operating characteristics.....	29
Environmental and Protection characteristics.....	29

General Information

General Description, Electric and Electronics

Automotive-on PLUS+1 (AoP+1), system description

The Automotive-on PLUS+1 is designed to control a single-path hydrostatic transmission system consisting of one pump and one hydrostatic motor. The flexible system configuration allows use of a wide range of hydrostatic pumps and motor configurations.

The AoP+1 is optimized for use with a hydrostatic motor equipped with Pressure Control Override (PCOR) or Proportional (PROP) valve to control pressure or motor displacement. Additionally a Brake Pressure Defeat (BPD) digital control valve can override the hydraulic pressure control during vehicle decelerating.

Parking Brake, Reverse Motion buzzer, Forward/Reverse-Lamp-Indicator, Retarder output and a Vehicle speed controlled output can be controlled with additional four digital output. All functions may not be available simultaneously.

The AoP+1 can read several analog, digital, and frequency signals representing operator input, system demands, and machine status inputs.

The CAN Communication Interface (SAE J1939) is used for diagnosis purposes and for information exchanging with other controllers such as engine, or customer-controllers.

Automotive on PLUS+1 advanced functions

The Automotive-on PLUS+1 commands the basic vehicle driving behavior and performance (i.e. acceleration, deceleration, and vehicle speed). The operator selects the driving mode, driving direction, and basic transmission set point command via throttle or Creep/Drive pedal. An additional input, the inch pedal command, can be used to override the basic transmission command.

A number of advanced features can be independantly activated and configured depending upon the application.

Below is a list of the primary advanced functions:

- Engine and Motor Over-Speed Protection
- Engine Anti stall
- Constant Speed Control
- Vehicle Speed Limitation
- Intelligent Operator Presence Detection
- Maximum Motor Torque at Vehicle Start
- Retarder control

Required Controller

The Automotive-on PLUS+1 application is designed for a specific MC024-021 "Automotive on PLUS+1" with the order number 11106112.

General Information

Mode Types

Hydrostatic propel methods

The application software provides 3 different hydrostatic propel methods, defined as mode types, which can be calibrated individually.

- **Automotive**

Proportional pump (displacement) and motor (displacement or PCOR) control valve current is defined by the Automotive Curve,

- **Non-Automotive**

Drive-Pedal controlled proportional pump (Displacement) and motor (Displacement or PCOR) control valve current, but Engine RPM independent,

- **Creep-Automotive**

like "Automotive", but Creep-Potentiometer limitation of the Automotive Curve of the pump.

Automotive and Creep-Automotive mode types are primarily intended for Wheel Loader and Telescopic Handler applications.

The Non-Automotive mode type is primarily intended for Sweeper, Forestry, and Forklift applications.

Each selectable system mode can be configured as one of the 3 mode types (hydrostatic propel methods) below:

- Automotive Mode
- Non-Automotive Mode
- Creep-Automotive Mode; (combination of Automotive and Non-Automotive)

General Information

Automotive Mode

In Automotive Mode the current to the proportional valves is directly controlled by the measured engine RPM. The current is independently parameter configurable for pump and motor in each mode. The Automotive Mode provides good anti-stall behavior due to the load dependent control.

The profile curve (points 0-7) of the Automotive Mode drive curve are set according to the available torque characteristics of the engine, accounting for additional auxiliary power.

Pump drive curve

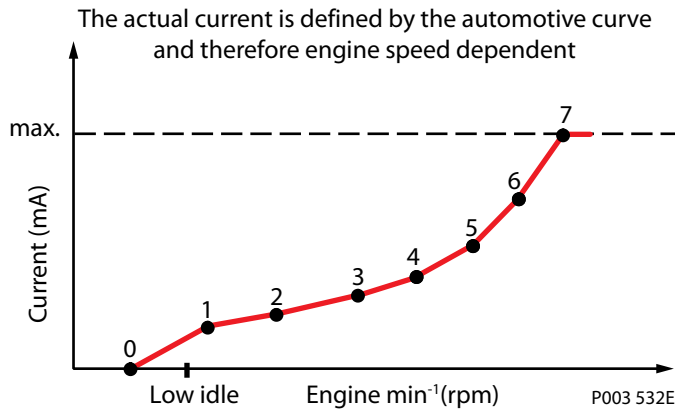

Motor drive curve

De-energized (no current) = Motor at min. displacement
H1B Motor controls M1, M2, K1, K2, T1, T2, P1, P2

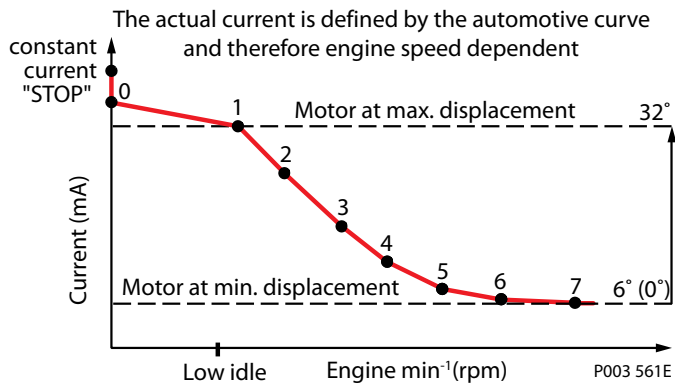

De-energized (no current) = Motor at max. displacement
H1B Motor controls L1, L2, D1, D2, E1, E2

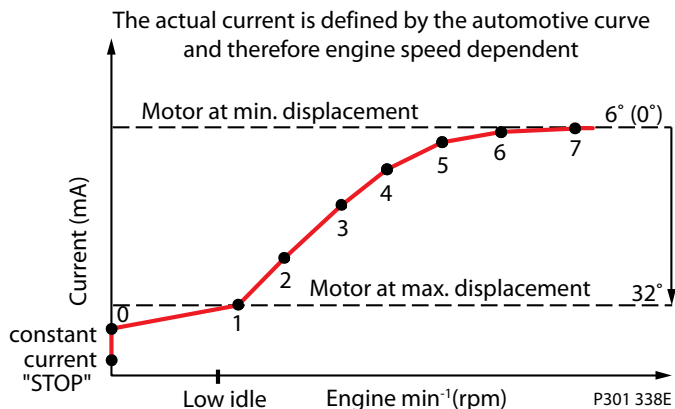

General Information

Non-Automotive Mode

The Non-Automotive Mode uses an analog input signal from the drive pedal to command vehicle speed.

The pump and motor valve currents are controlled by the system mode profile and are independent of pump speed.

Pump drive curve

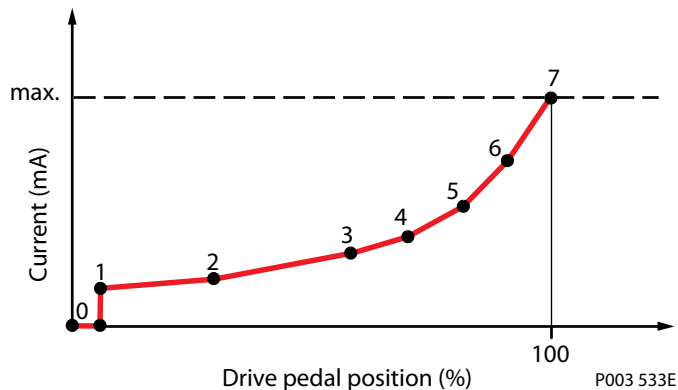

Motor drive curve

De-energized (no current) = Motor at min. displacement
H1B Motor controls M1, M2, K1, K2, T1, T2, P1, P2

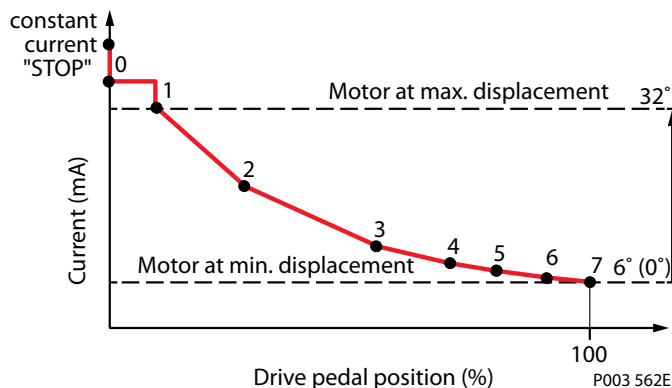

De-energized (no current) = Motor at max. displacement
H1B Motor controls L1, L2, D1, D2, E1, E2

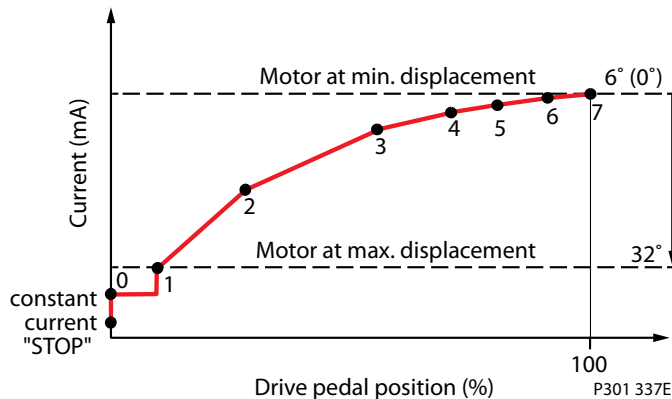

General Information

Creep-Automotive Mode

Creep-Automotive Mode is a combination of both Automotive and Non-Automotive Mode. Creep Automotive Mode uses an analog input signal (Drive/Creep Potentiometer) to control the pump valve current. The available pump valve current is limited by the automotive curve dedicated to this mode type.

The actual current to the pump valve is the product of the actual engine RPM, the defined automotive curve, and the actual percentage of Drive/Creep Potentiometer input. Creep-Automotive is active above a user defined "Creep Start RPM", below this RPM the propel system behaves like Automotive-Mode.

The motor valve current follows the automotive curve like in Automotive Mode.

Actual engine RPM = $1800 \text{ min}^{-1} \Rightarrow I_{\text{Automotive-Curve}} = 1500 \text{ mA}$;

Actual Pedal value = 40%;

Creep Start RPM = $1050 \text{ min}^{-1} \Rightarrow I_{\text{CreepStart}} = 825 \text{ mA}$;

$I_{\text{Valve}} = [(1500 - I_{\text{CreepStart}}) * 40 / 100] + I_{\text{CreepStart}} = 1095 \text{ mA}$

Pump drive curve

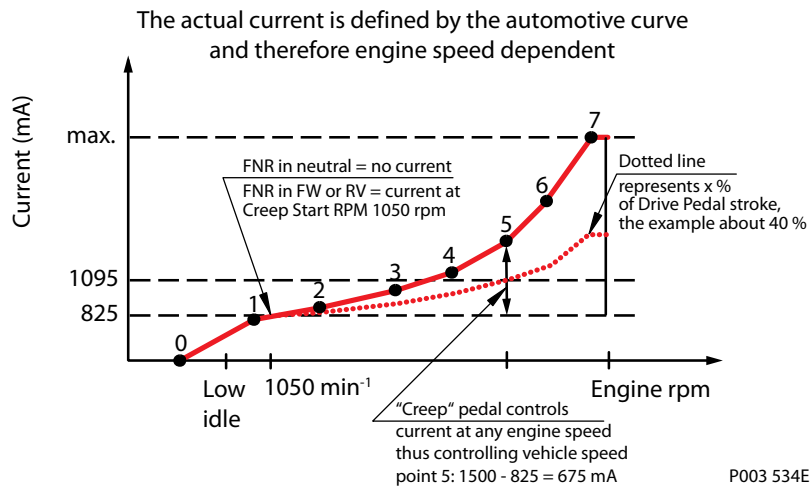

General Information

Motor drive curve

De-energized (no current) = Motor at min. displacement
 H1B Motor controls M1, M2, K1, K2, T1, T2, P1, P2

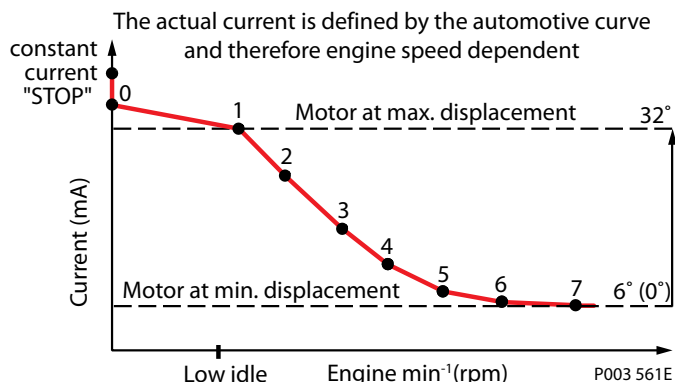

De-energized (no current) = Motor at max. displacement
 H1B Motor controls L1, L2, D1, D2, E1, E2

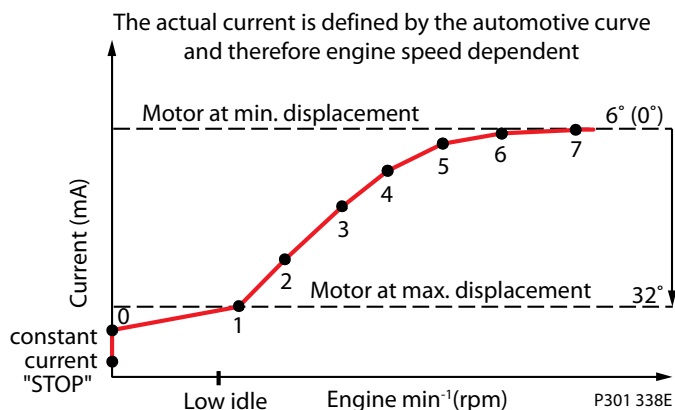

System modes and selection

The application simultaneously supports up to 4 system modes. The system modes define the basic characteristic of the transmission and are operator selectable via 2 digital inputs: Mode Switch A and Mode Switch B.

Each of the four system modes can be:

- optimized for driving behavior through independent drive curves with individual pump and hydrostatic motor ramping.
- configured as any one of the mode types (propel methods).

The following table describes the relationship between the digital input mode switches and the resulting system modes:

Modes and selection

	System mode			
	Mode 1	Mode 2	Mode 3	Mode 4
Mode switch A	Low	Low	High	High
Mode switch B	Low	High	Low	High

General Information
Application Function
Application function description

	Description
1.	<p>Independent Pump/Motor-Profiling & Ramping</p> <p>Both the pump and motor can be independently configured for the forward and reverse driving direction. The application software facilitates individual command profiles (8 points) based on pump RPM or drive pedal inputs. Additionally vehicle acceleration timing (1 ramp) and deceleration timing (3 ramps plus 1 error ramp) are independently configurable.</p>
2.	<p>4 Selectable System-Modes</p> <p>The application supports 4 configurable System Modes which are selectable with digital inputs Mode Switch A and Mode Switch B. Each System Mode can be individually configured through Mode Type (Automotive, Creep-Automotive, Non-Automotive) and all advanced functions (e.g. CSD, Antistall, Overspeed Protection, etc).</p>
3.	<p>Configurable System-Mode- & Direction-Change</p> <p>This function allows configuration of an application specific System Mode transition. The System Mode change condition can be dependent on multiple factors including actual FNR Direction, Drive Pedal Input, and Ground Speed.</p> <p>The vehicle driving direction change can be configured on vehicle speed.</p> <p>When a momentary FNR switch logic is configured, the driving direction change request is rejected if the vehicle speed is above a predefined speed.</p>
4.	<p>Configurable Operator-Presence-Detection (only via CAN-BUS)</p> <p>In primary configuration, an open seat switch (operator not in the seat), programmable with or without time delay, will trigger vehicle shut down. In secondary configuration, the open seat switch requires a secondary operator presence indicator, such as the release of throttle, drive pedal, or inch pedal, to trigger vehicle shut down</p>
5.	<p>Pump Displacement Control:</p> <p>The software provides a displacement control for NFPE (Non-Feedback Proportional Electric) or EDC (Electrical Displacement Control) pumps. The pump command can be defined by a profile curve which can be dependent on engine speed (Automotive Mode, Creep-Automotive Mode) or the drive pedal (Non-Automotive Mode) The current change (stroke time) is configurable by ramps during initial vehicle set up.</p>
6.	<p>Motor Displacement Control: Proportional, Variable-PCOR or Two-Position</p> <p>The software facilitates Motor Displacement Control for Proportional, Variable PCOR, and Two Position control types. The motor command can be defined by a constant value or a profile curve which can be dependent on engine speed (Automotive Mode, Creep-Automotive Mode) or the drive pedal (Non-Automotive Mode). The motor valve current change (stroke timing) is configured by ramps defined during initial vehicle set up.</p>
7.	<p>Motor BPD-Control</p> <p>The Motor Brake Pressure Defeat Control prevents the activation of the internal motor control pressure compensator (PCOR) during deceleration events. The Motor BPD Control activation can be configured individually for driving direction. For change of driving direction the control timing can be configured as state change or actual motor direction dependent.</p>
8.	<p>Brake Test Mode</p> <p>The Brake Test Mode allows the hydrostatic transmission system to drive against the applied park brake and can be individually configured for each System Mode.</p> <hr/> <p><i>The Brake Test Mode cannot be used during normal operation.</i></p>
9.	<p>Parking-Brake-Control</p> <p>The Parking Brake Control digitally activates (apply/release) a park brake. Park brake activation can be vehicle speed dependent with additional dependency on:</p> <ul style="list-style-type: none"> • Software machine state in STOP mode • Actual pump valve current below user defined value • Actual inch pedal command exceeds user defined value. <p>Delay times for park brake application and release are individually configurable.</p>
10.	<p>Reverse-Driving-Direction-Buzzer-Output</p> <p>The Reverse Driving Direction Buzzer Output controls a buzzer that indicates reverse driving direction. The output logic can be directly controlled by FNR status or by actual propel movement.</p>
11.	<p>Forward- and Reverse-Direction-LED Output</p> <p>The Forward and Reverse Direction LED Output function digitally drives LEDs as driving direction indicators for use in dashboard/display and is directly linked to the FNR status.</p>
12.	<p>Fault-Status-Output (Red-LED)</p> <p>The Fault Status Output provides an output signal of the internal fault status/error code capable of digitally driving an LED.</p>

General Information
Application function description (continued)

	Description
13.	<p>Brake-Light-Output The Brake Light Output digitally drives an indicator lamp (within the specified hardware output limits) when the inch pedal command exceeds a user defined value.</p>
14.	<p>Vehicle-Speed-Dependent Output-Signal The Vehicle Speed Dependent Output Signal toggles a digital output when the actual vehicle speed exceeds an user defined speed.</p>
15.	<p>Retarder Control (Engine Speed Dependent Output-Signal) The Engine Speed Dependent Output-Signal toggles a digital output when the actual engine speed exceeds an user defined speed. It can be used to control a retarder function to support the braking capability of the engine.</p>
16.	<p>Safety controlled Vehicle Start-Protection To release the start-protection the following signals will be checked:</p> <ul style="list-style-type: none"> • Engine RPM • Battery voltage • Error status • Inch calibration • FNR in neutral
17.	<p>Engine Anti-Stall especially for Non-Automotive (All- & Fixed-Pump Speed Range) The Engine Anti-Stall prevents the engine from being stalled due to overload through the transmission system. There are two independent Engine Anti-Stall Modes: Fixed-Engine-RPM and All-Range Engine RPM. Fixed-Engine-RPM: Fixed-Engine-RPM anti-stall is used in applications operating at fixed engine speeds. If the actual pump speed droops below the target fixed engine speed the software PI-Controller will reduce the pump valve current to achieve/maintain the target fixed engine speed. All-Range-Engine-RPM: The engine speed command and the actual pump speed will be compared to calculate the engine speed droop. If the actual pump speed is below the user defined engine speed droop the software PI-controller will reduce the pump valve current to reduce engine load and prevent further engine speed droop. The Engine Anti-Stall can be individually enabled for each System Mode.</p>
18.	<p>Engine Over Speed Protection (EOP) during inching This protection function is only activated while inching and if the actual pump (engine) speed is above the configured "Start RPM". If this configured speed is exceeded, the inching command is reduced towards 0 proportional to engine speed increase. Once inching command is reduced to 0 further engine speed increases cannot be controlled. In case of engine over-speed due to downhill driving (exceeding the braking performance of the engine) mechanical brakes are needed to protect the engine.</p>
19.	<p>Vehicle Constant-Speed-Drive (CSD) via drive pedal command and motor speed sensor (Non-Automotive only) The CSD function ("CSD by pedal command") compares the drive pedal command for vehicle speed with the actual vehicle speed. Actual vehicle speed is calculated using measured motor speed, gear ratio, and wheel diameter where 100 % Pedal Position is the maximum vehicle speed in either the forward or reverse direction. If the actual vehicle speed differs from the commanded speed, the software PI-Controller will adjust the pump valve current to compensate for the speed difference. This function can be individually System Mode enabled and configured.</p> <hr/> <p>This function requires motor or vehicle speed sensor.</p>
20.	<p>Vehicle CSD (Constant-Speed-Drive) via measured pump rpm command (calculated flow) and motor speed sensor (Automotive & Creep-Automotive only) This CSD function ("CSD by pump flow") calculates pump flow via pump speed and predicted pump swash plate angle. Swash plate angle is predicted based on factory calibrated pump valve current relationship (e.g. 800 mA = 0°, 1200 mA = 18°). The software will calculate the desired motor speed based on the predicted swash plate angle, actual pump rpm, and the max. motor displacement. If the actual vehicle speed differs from the commanded speed, the software PI-Controller will adjust the pump valve current to compensate for the speed difference.</p> <hr/> <p>This function requires motor or vehicle speed sensor but can be used without a drive pedal input.</p>
21.	<p>Vehicle-Speed-Limit via motor speed sensor The Vehicle Speed Limit is a general vehicle speed limitation that compensates for volumetric pump and motor losses. This function can be independently activated in each System Mode and driving direction. If the actual vehicle speed exceeds the defined vehicle speed limit the software PI-Controller function will reduce pump valve current until the speed limit is met.</p> <hr/> <p>This function requires a motor or vehicle speed sensor.</p>

General Information

Application function description (continued)

	Description
22.	<p>Motor Over Speed Protection (MOP) The Motor Over Speed Protection (MOP) prevents the hydrostatic motor from over speeding by either decreasing pump displacement or increasing motor displacement (only applies to electrical proportional motor control). The motor RPM speed limit, based on a software PI Algorithm, is user defined but is universally constant for all four System Modes when activated.</p> <hr/> <p>The Engine Overspeed Protection (EOP) during inching has priority and will override the Motor Over Speed Protection (MOP).</p>
23.	<p>Maximum motor displacement (torque) at vehicle start and low vehicle speed The Maximum Motor Displacement function provides maximum system torque at initial vehicle acceleration and at near zero speeds during deceleration by shifting to or maintaining motor maximum displacement.</p>
24.	<p>J1939-CAN Engine Interface The application software can send/receive SAE J1939 protocol compliant CAN messages from/to an engine controller. The following standard messages are supported: TSC1 (Torque/speed control), EEC1 (pump/engine rpm) and EEC2 (drive pedal) All messages can be individually activated and designated for usage.</p>
25.	<p>J1939-CAN Subsystem-Data Interface The application software can send/receive CAN information to/from the vehicle system. The following standard messages are supported: TSC1 (Torque/speed control), EEC1 (pump/engine rpm), EEC2 (drive pedal), EBC1 (Inch pedal), ETC5 (FNR), VH (vehicle hours), RC I (brake remote control), OPS (operator presence), CCVS (vehicle speed), VEP1 (battery voltage). Additional Danfoss specific (proprietary) messages are available to share information about Mode switches, Hydro motor rpm, Transmission state and error messages. All messages can be individually activated and designated for usage.</p>
26.	<p>J1939-CAN Shared Engine Speed Control with Safety Monitoring The application software generates based on the drive pedal signal a desired engine speed. The AoP+1 Controller sends the desired engine speed message (TSC1) with a destination address modified PGN to an external controller. This external controller is either transmitting this Automotive Control desired engine speed or a modified engine speed to the engine controller. This function provides the possibility, to allow an External-Controller to modify the desired engine speed if the vehicle is in STOP. The AoP+1 controller monitors the external controller engine speed signal for verification. If this engine speed signal is out of a configured tolerance and the Vehicle not in STOP, the AoP+1 will ramp down into SAFE State to stop the vehicle.</p>

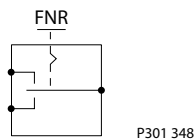
General Information
General customer / sensor requirements

- 2-Layer switch with continuous signal
- Separate output signals for FORWARD and REVERSE indication as input signals of the MC-24 connector pins for C1p06 and C1p07.
- Switch to be supplied by battery voltage
- Switch to be compliant to the input resistance of the digital input
- No loads (e.g. valve) in parallel
- Gold-plated contacts are recommended

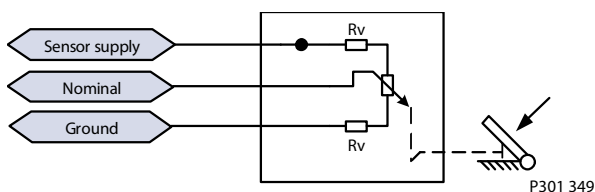
Drive / Creep / Joystick / Rocker and inch pedal

- Sensor must be supplied with MC24 sensor supply voltage and must not exceed the max output current (overload)
- The signal is used as the source of pedal position signal information
 - The voltage range of the output signals must not be lower than 5% and not higher than 95% of sensor voltage.
 - Upper and lower voltage limits to sensor supply required for wire-fault detection.
 - The resistor value has to be approximately 7% of the poti resistance value. The voltage of the input must increase when the pedal is pushed.

Potentiometer resistance	Rv
1 kΩ	68 Ω
5 kΩ	330 Ω
10 kΩ	680 Ω

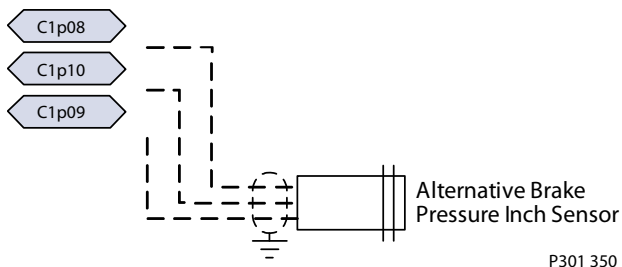
Pressure inch sensor

- The input signal is direct measurement of the hydraulic braking pressure. The inch function only supports the vehicle brake system to prevent driving against the brakes.
- The voltage range of the output signals must not be lower than 5% and not higher than 95% of sensor voltage.
- Upper and lower voltage limits to sensor supply required for wire-fault detection

General Information

- In case of an internal detected error, the sensor output signal has to be clamped by the sensor to sensor supply voltage. This feature enables the application software to recognize this failure.
- Sensor must be supplied with MC24 sensor supply voltage and must not exceed the max output current (overload)

Mode switch A

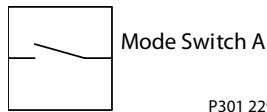

- Switch to be supplied by battery voltage
- Switch to comply with input resistance of the digital input
- No loads (e.g. valve) in parallel
- Gold-plated contacts are recommended

Mode switch B

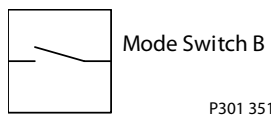

- Switch to be supplied by battery voltage
- Switch to comply with input resistance of the digital input
- No loads (e.g. valve) in parallel
- Gold-plated contacts are recommended

HST / Motor / PPU

- Sensor should be supplied by the sensor supply voltage of the MC-24 and should not overload the output
- Sensors supplied by battery voltage are possible, if the output signal fits into the specific signal range.
- Upper and lower voltage limits for the output signals below sensor supply are required for wire-fault detection
- The voltage range of the output signals must not be lower than 6% and not higher than 94% of sensor voltage.
- PPU must comply with input resistance of the RPM input
- Recommended speed and direction sensor No. **11046759**

Pump displacement

The two PWM outputs are supplied with battery voltage and must not exceed the max output current (overload)

Motor displacement and Brake Pressure defeat (BPD)

The digital and PWM Outputs are supplied with battery voltage and must not exceed the max output current (overload)

Digital outputs 1, 2, 3, 4

The digital Outputs are supplied with battery voltage and must not exceed the max output current (overload)

General Information

Automotive Control connection diagram

- 1 Contact capability min. 20A
- 2 Melting fuse 20A
- 3 Max. 3A each pin
- 4 Functional options

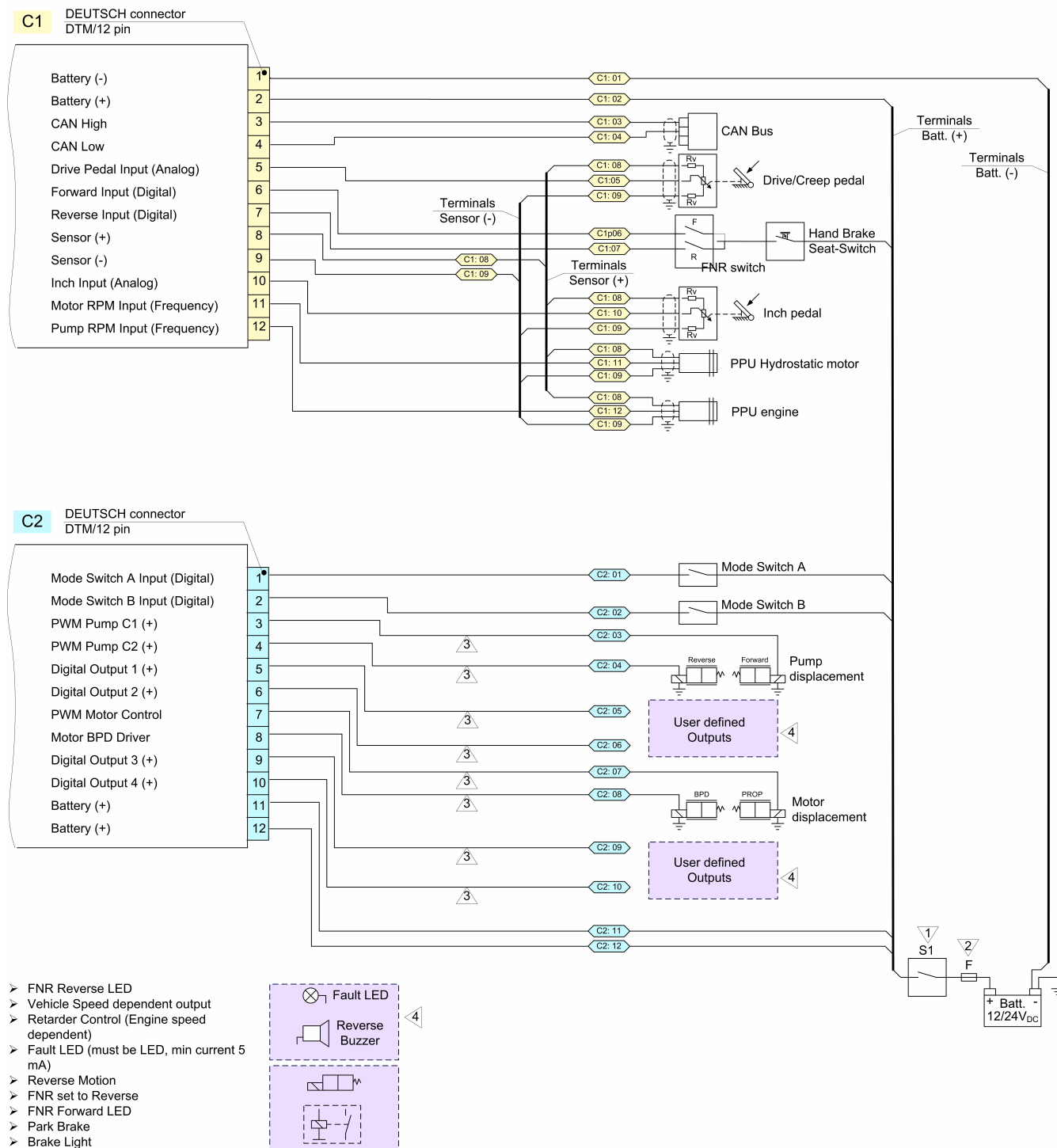

Technical Specifications
Input signals: Power supply – Battery

The Automotive on PLUS+1 can be supplied with 12 V or 24 V system.

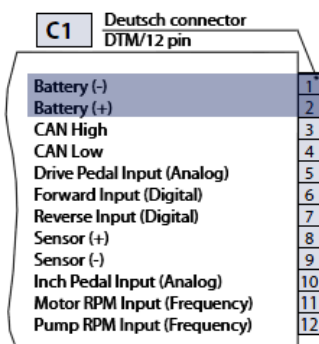

Power supply input from the battery:

- **C1: 01 - Battery (-)**
- **C1: 02 - Battery (+)**

The 5 V_{DC} sensor supply is internally generated. The sensor supply is protected against overload and reverse polarity connection. The maximum supply current is 200 mA.

Parameter	Min	Max
Battery supply current	-	18 A
Recommended fuse size	-	20 A
Permanent supply voltage range	9 V _{DC}	36 V _{DC}
Rated 12 V range	9 V _{DC}	16 V _{DC}
Rated 24 V range	18 V _{DC}	32 V _{DC}
Permanent reverse voltage protection	-	-36 V _{DC}
Sensor supply voltage range (internal)*	4.88 V _{DC}	5.12 V _{DC}
Sensor supply current*	-	200 mA

* max 200 mA for all sensors together.

It is strongly recommended to switch the power supply for the AoP+1 controller together with the power supply to the engine to avoid misleading errors. This even includes the use of emergency stops, safety switched etc.

Mating connectors are available from Danfoss. For details see [Mating Connectors](#) on page 26.

For electrical details, please refer to the *Technical Information PLUS+1 Controller Family, 520L0719*.

Technical Specifications
Input signals: Forward-Neutral-Reverse (FNR) switch

The FNR-switch selects the driving direction.

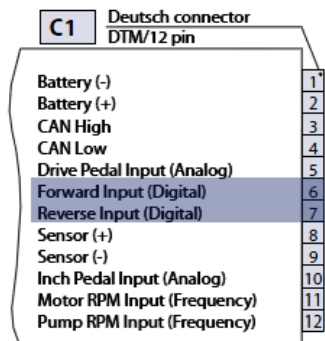

Digital input for driving direction Forward/Reverse, switched to the battery supply (12/24 V):

- **C1:06-Forward Input**
- **C1:07-Reverse Input**

Parameter	Min	Max
Rising voltage threshold ¹⁾	2.80 V _{DC}	4.15 V _{DC}
Falling voltage threshold ²⁾	1.01 V _{DC}	2.77 V _{DC}
Input Impedance	13.9 kΩ	15.5 kΩ

¹⁾ A digital input is guaranteed to be read as high if the voltage is greater than 4.15 V_{DC}.

²⁾ A digital input is guaranteed to be read as low if the voltage is less than 1.01 V_{DC}.

Mating connectors are available from Danfoss. For details see [Mating Connectors](#) on page 26.

For electrical details, please refer to the *Technical Information PLUS+1 Controller Family, 520L0719*.

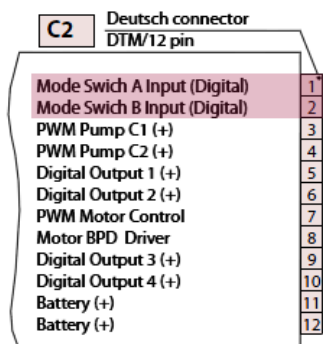
Technical Specifications
Input signals: Mode switch

Digital input for mode switch A/B switched to battery supply (12/24 V):

- **C2:1-Mode switch A Input**
- **C2:2-Mode switch B Input**

The Mode switches select the 4 possible system modes according to the table below:

Modes and selection

	System mode			
	Mode 1	Mode 2	Mode 3	Mode 4
Mode switch A	Low	Low	High	High
Mode switch B	Low	High	Low	High

Parameter	Min	Max
Rising voltage threshold ¹⁾	2.8 V _{DC}	4.15 V _{DC}
Falling voltage threshold ²⁾	1.01 V _{DC}	2.77 V _{DC}
Input Impedance	13.9 kΩ	15.5 kΩ

¹⁾ A digital input is guaranteed to be read as high if the voltage is greater than 4.15V.

²⁾ A digital input is guaranteed to be read as low if the voltage is less than 1.01V.

Mating connectors are available from Danfoss. For details see [Mating Connectors](#) on page 26.

For electrical details, please refer to the *Technical Information PLUS+1 Controller Family, 520L0719*.

Technical Specifications
Input signals: Inch pedal

The inch pedal allows the operator to reduce the vehicle speed, stop the machine or keep the vehicle speed low while raising the engine speed to meet auxiliary flow demands.

An increasing inch pedal signal will reduce the pump displacement, thus reducing vehicle speed. Additionally, the motor can be increased to maximum displacement at the same time. The vehicle will come to a complete stop at 100 % inch signal. The inch pedal signal can be used to control a brake light output.

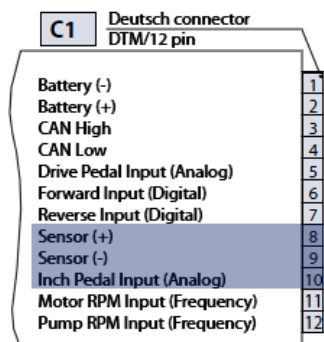

- **C1:08-Sensor (+)** – Sensor supply (+)
 - Supply for sensors within 4.88 to 5.12 V_{DC}
 - Max. output current is 200 mA.
- **C1:09-Sensor (-)** – Sensor supply (-) direct GROUND
- **C1:10-Inch Input** – Analog Input for the inch signal

Parameter	Min	Max
Input voltage range	0.08 V _{DC}	5.26 V _{DC}
Precision		1.28 mV _{DC}
Input Impedance	206 kΩ	236 kΩ

Mating connectors are available from Danfoss. For details see [Mating Connectors](#) on page 26.

For electrical details, please refer to the *Technical Information PLUS+1 Controller Family, 520L0719*.

Technical Specifications
Input signals: Drive/Creep pedal, Joystick and Rocker pedal

The Drive/Creep pedal and the Rocker pedal allow the operator to command the vehicle speed through pump and motor displacement setpoint. The displacement setpoint is defined by the configured profile and ramp for the 2 mode types:

1. Non-Automotive:

- Pump displacement
- Motor displacement:

2. Creep-Automotive:

- Pump displacement only
- Motor displacement will follow the engine speed

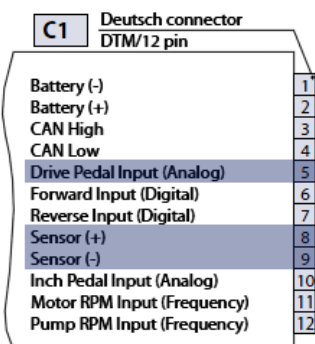

All advanced functions, e.g. Anti stall, CSD, Over speed protection can override this command.

The Drive/Creep pedal, only provides a driving command. The driving direction is selected by the FNR input.

The Rocker pedal and Joystick provides a driving command and the driving direction signal.

Whether a Drive/Creep pedal, Joystick or a Rocker pedal is used will be configured by parameters.

The pedal output signal can be configured and sent by the MC-024 as engine rpm command for the J1939-CAN message TSC1.

- **C1:08-Sensor (+)** – Sensor supply (+)
 - Supply for sensors within 4.88 to 5.12 V_{DC}
 - Max. output current is 200 mA.
- **C1:09-Sensor (-)** – Sensor supply (-) direct GROUND
- **C1:05-Drive Pedal Input** – Analog Input for Drive/Rocker Pedal, Joystick or Creep Potentiometer

Parameter	Min	Max
Input voltage range	0.08 V _{DC}	5.26 V _{DC}
Precision		1.28 mV _{DC}
Input Impedance	206 kΩ	236 kΩ

Mating connectors are available from Danfoss. For details see [Mating Connectors](#) on page 26.

For electrical details, please refer to the *Technical Information PLUS+1 Controller Family*, **520L0719**.

Technical Specifications
Input signals: Motor speed sensor

A motor speed sensor signal can be read by the MC-024 and used to calculate vehicle speed utilizing the configured final drive ratio. The calculated vehicle speed enables advanced functions such as constant speed operation and maximum vehicle speed limitation.

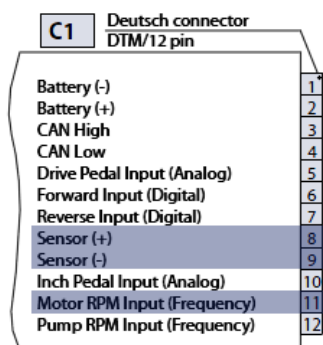

- **C1:08-Sensor (+)** – Sensor supply (+)
 - Supply for sensors within 4.88 to 5.12 V_{DC}
 - Max. output current is 200 mA.
- **C1:09-Sensor (-)** – Sensor supply (-) direct GROUND
- **C1:11-Motor RPM Input (Frequency)** – Frequency input for hydrostatic motor (PPU sensor)

Frequency Input (Motor RPM)

Parameter	Min	Max	Note
Rising voltage threshold (middle range)	2.92 V _{DC}	4.12 V _{DC}	The frequency input is guaranteed to be read as high if the voltage is greater than 4.12 V _{DC}
Falling voltage threshold (middle range)	1.02 V _{DC}	2.75 V _{DC}	The frequency input is guaranteed to be read as low if the voltage is less than 1.02 V _{DC}
Input Impedance	7.17 kΩ	7.37 kΩ	15 kΩ to sensor supply / 13.5 kΩ to GND
Frequency range	0 Hz	10 000 Hz	In steps of 1 Hz

Mating connectors are available from Danfoss. For details see [Mating Connectors](#) on page 26.

For electrical details, please refer to the *Technical Information PLUS+1 Controller Family, 520L0719*.

Technical Specifications
Output signals: Pump displacement control

Displacement control for pumps with a Non-Feedback Proportional Electric (**NFPE**) or Electrical Displacement Control (**EDC**). The pump command can be defined by the profile curve which can be dependent on the engine speed (Automotive Mode, Creep-Automotive Mode) or the drive pedal (Non-Automotive mode).

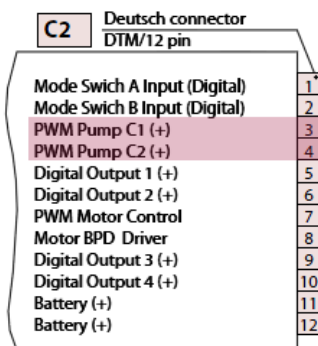

- **C2:03-Pump displacement control forward** – Proportional output (+) for the pump displacement control
 - PWM Signal from battery Supply (12/24V)
- **C2:04-Pump displacement control reverse** – Proportional output (+) for the pump displacement control
 - PWM Signal from battery Supply (12/24V)

PWM Output

Parameter	Min	Max
Proportional current	10 mA	3000 mA
PWM frequency	33 Hz	200 Hz
Output voltage	–	Supply

Mating connectors are available from Danfoss. For details see [Mating Connectors](#) on page 26.

For electrical details, please refer to the *Technical Information PLUS+1 Controller Family, 520L0719*.

Technical Specifications
Output signals: Motor displacement and Brake Pressure Defeat (BPD) control

Variable displacement and 2-Position motors can be controlled directly. The output signal may be controlled by pump (engine) speed or drive pedal position.

For vehicle braking conditions a Brake Pressure Defeat (BPD) valve can be controlled dependent on the driving direction.

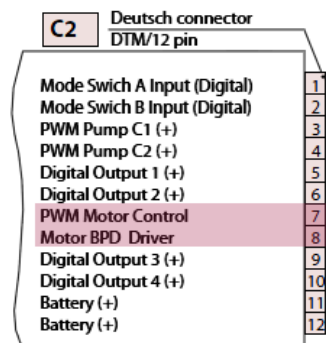

- **C2:07-Motor PROP/PCOR Driver** – Proportional output (+) for the **Pressure Control OverRide** or Proportional motor valve
 - PWM Signal from battery Supply (12/24V)
- **C2:08-Motor BPD Driver** – Digital output for the **Brake Pressure Defeat** valve
 - Switched to battery Supply (12/24V)

Digital Output

Parameter	Min	Max
Output current	0 mA	3000 mA
Output voltage	–	Supply

Mating connectors are available from Danfoss. For details see [Mating Connectors](#) on page 26.

For electrical details, please refer to the *Technical Information PLUS+1 Controller Family, 520L0719*.

Technical Specifications

Output signals: Digital outputs 1, 2, 3, 4

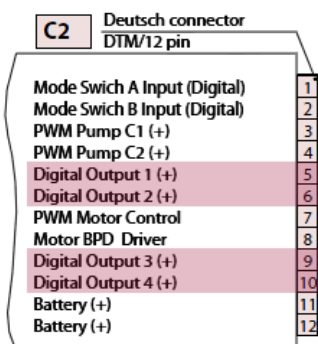

- **C2:05-Output 1** Switched to battery (+) supply
- **C2:06-Output 2** Switched to battery (+) supply
- **C2:09-Output 3** Switched to battery (+) supply
- **C2:10-Output 4** Switched to battery (+) supply

The digital outputs 1, 2, 3, 4 can be used as single outputs (open loop - switch to battery supply).

The outputs can be configured individually to operate as:

- Brake light,
- Vehicle speed dependent signal
- Retarder control (engine speed dependent output)
- Status (Fault) LED
- Park brake
- FNR in forward
- FNR in reverse
- Reverse motion
- Reverse LED

Digital Output

Parameter	Min	Max
Output current	0 mA	3000 mA
Output voltage	-	Supply

Mating connectors are available from Danfoss. For details see [Mating Connectors](#) on page 26.

For electrical details, please refer to the *Technical Information PLUS+1 Controller Family, 520L0719*.

Technical Specifications
CAN Communication: Input and Output signals

CAN communication is possible via the CAN connector. The physical (hardware) layer operates using the CAN 2.0B specification for communication with either the PLUS+1 Service Tool or other external devices. The J1939 protocol is enabled for communicating with other external devices.

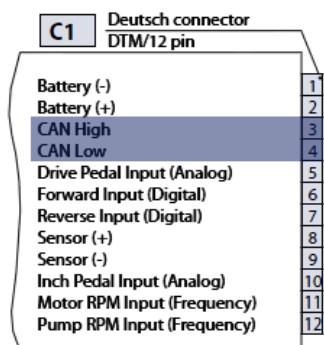

- **C1:03-CAN High** – Communication connection for CAN high line
- **C1:04-CAN Low** – Communication connection for CAN low line

CAN Communication

Parameter	Max
CAN Baudrate, physical layer per ISO11898-2; high speed	250 kBaud

Mating connectors are available from Danfoss. For details see [Mating Connectors](#) on page 26.

For electrical details, please refer to the *Technical Information PLUS+1 Controller Family - 520L0719*.

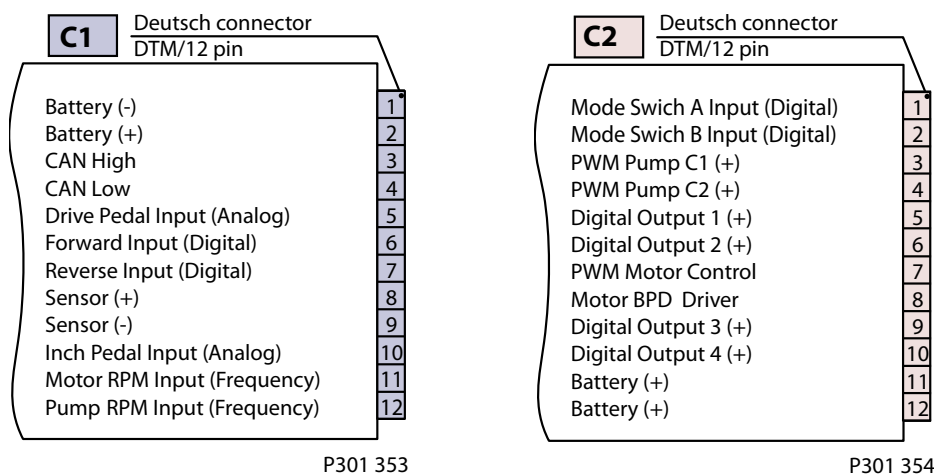
Technical Specifications
Mating Connectors
Customer connector: 1, 2 (C1, C2)

There are two available kits, differentiated by customer wire diameter, containing both C1 and C2 mating connectors.

Customer connector 1 (C1) and 2 (C2)

Name	Lead wire diameter	Material No.
Assembly Bag with 2 DEUTSCH Connectors DTM06 12-SOCKET Black/Grey and gold plated pins	0.5-1.0 mm ² / (16-20 AWG)	10102023
Assembly Bag with 2 DEUTSCH Connectors DTM06 12-SOCKET Black/Grey and gold plated pins (recommended)	0.2-0.5 mm ² / (20-24 AWG)	10100945

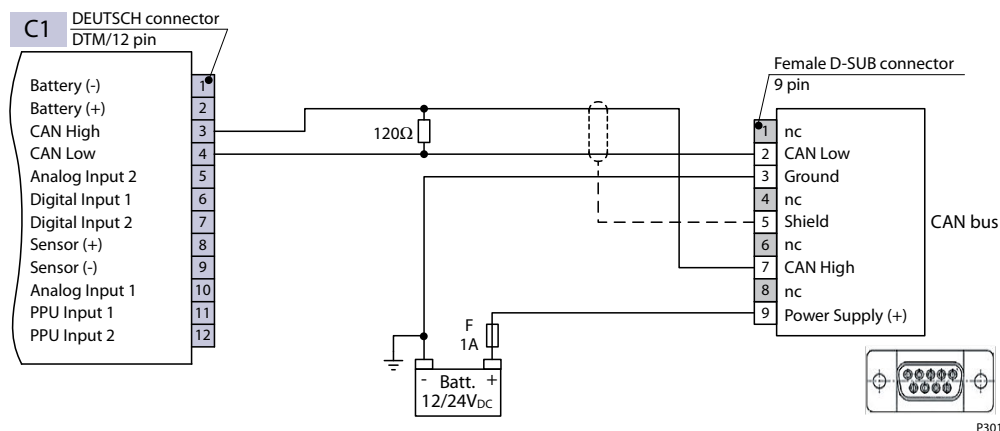
Technical Specifications
CAN Bus adapter cable

The additional **Adapter Cable H1P AC CAN Guide**, Material number: **11069593** is required to connect the CG150 CAN USB Gateway with the Automotive Control (MC24).

The pigtail cable transitions from Deutsch to DSUB connector and contains terminating resistors to enable CAN communication.

Bill of material:

- CAN Deutsch Connector DTM06 3-12S; Material No. **10102023**
- 9 pin female D-SUB Connector with housing
- 120 Ω resistor ¼W ± 5% or better
- 1 m cable 3 wire, diameter 0.2 to 1.0 mm² (0.5 mm² recommended)

[If using a cable longer than 1 m, a shielded cable is required. For further information see the J1939 specification.](#)

AC Electrical Data & Characteristics

For electrical details, please refer to the *Technical Information PLUS+1 Controller Family - 520L0719*

Supply characteristics

Parameter	Min	Max
Battery supply current	-	18 A
Recommended fuse size	-	20 A
Permanent supply voltage range	9 V _{DC}	36 V _{DC}
Rated 12 V range	9 V _{DC}	16 V _{DC}
Rated 24 V range	18 V _{DC}	32 V _{DC}
Permanent reverse voltage protection	-	-36 V _{DC}
Sensor supply voltage range (internal)*	4.88 V _{DC}	5.12 V _{DC}
Sensor supply current*	-	200 mA

* max 200 mA for all sensors together.

Technical Specifications
I/O characteristics
Digital inputs

Parameter	Min	Max
Rising voltage threshold ¹⁾	2.80 V _{DC}	4.15 V _{DC}
Falling voltage threshold ²⁾	1.01 V _{DC}	2.77 V _{DC}
Input Impedance	13.9 kΩ	15.5 kΩ

¹⁾ A digital input is guaranteed to be read as high if the voltage is greater than 4.15 V_{DC}.

²⁾ A digital input is guaranteed to be read as low if the voltage is less than 1.01 V_{DC}.

Analog inputs

Parameter	Min	Max
Input voltage range	0.08 V _{DC}	5.26 V _{DC}
Precision		1.28 mV _{DC}
Input Impedance	206 kΩ	236 kΩ

Frequency Input (Motor RPM)

Parameter	Min	Max	Note
Rising voltage threshold (middle range)	2.92 V _{DC}	4.12 V _{DC}	The frequency input is guaranteed to be read as high if the voltage is greater than 4.12 V _{DC}
Falling voltage threshold (middle range)	1.02 V _{DC}	2.75 V _{DC}	The frequency input is guaranteed to be read as low if the voltage is less than 1.02 V _{DC}
Input Impedance	7.17 kΩ	7.37 kΩ	15 kΩ to sensor supply / 13.5 kΩ to GND
Frequency range	0 Hz	10 000 Hz	In steps of 1 Hz

PWM Output

Parameter	Min	Max
Proportional current	10 mA	3000 mA
PWM frequency	33 Hz	200 Hz
Output voltage	–	Supply

Digital Output

Parameter	Min	Max
Output current	0 mA	3000 mA
Output voltage	–	Supply

Technical Specifications
Operating characteristics
Temperature range

Parameter	Min	Max
Application software download	0 °C	70 °C
Operation temperature	-40 °C	70 °C
Storage temperature	-40 °C	85 °C

CAN Communication

Parameter	Max
CAN Baudrate, physical layer per ISO11898-2; high speed	250 kBaud

Environmental and Protection characteristics

Parameter	Note
Short circuit	All inputs and outputs will withstand continuous short circuit to all other leads. When the short circuit is removed the unit returns to normal function.
EMC-Immunity (EMI)	100 v/m
EMC-Emission (RFI)	100 v/m
IP rating	IP67 with mating connectors attached
Vibration	IEC 600 68-2-64
Schock	IEC 600 68-2-27 test Ea



Products we offer:

- Bent Axis Motors
- Closed Circuit Axial Piston Pumps and Motors
- Displays
- Electrohydraulic Power Steering
- Electrohydraulics
- Hydraulic Power Steering
- Integrated Systems
- Joysticks and Control Handles
- Microcontrollers and Software
- Open Circuit Axial Piston Pumps
- Orbital Motors
- PLUS+1® GUIDE
- Proportional Valves
- Sensors
- Steering
- Transit Mixer Drives

Danfoss Power Solutions is a global manufacturer and supplier of high-quality hydraulic and electronic components. We specialize in providing state-of-the-art technology and solutions that excel in the harsh operating conditions of the mobile off-highway market. Building on our extensive applications expertise, we work closely with our customers to ensure exceptional performance for a broad range of off-highway vehicles.

We help OEMs around the world speed up system development, reduce costs and bring vehicles to market faster.

Danfoss – Your Strongest Partner in Mobile Hydraulics.

Go to www.powersolutions.danfoss.com for further product information.

Wherever off-highway vehicles are at work, so is Danfoss. We offer expert worldwide support for our customers, ensuring the best possible solutions for outstanding performance. And with an extensive network of Global Service Partners, we also provide comprehensive global service for all of our components.

Please contact the Danfoss Power Solution representative nearest you.

Comatrol

www.comatrol.com

Schwarzmueller-Inverter

www.schwarzmueller-inverter.com

Turolla

www.turollaocg.com

Hydro-Gear

www.hydro-gear.com

Daikin-Sauer-Danfoss

www.daikin-sauer-danfoss.com

Local address:

Danfoss Power Solutions (US) Company
2800 East 13th Street
Ames, IA 50010, USA
Phone: +1 515 239 6000

Danfoss Power Solutions GmbH & Co. OHG
Krokamp 35
D-24539 Neumünster, Germany
Phone: +49 4321 871 0

Danfoss Power Solutions ApS
Nordborgvej 81
DK-6430 Nordborg, Denmark
Phone: +45 7488 2222

Danfoss Power Solutions Trading (Shanghai) Co., Ltd.
Building #22, No. 1000 Jin Hai Rd
Jin Qiao, Pudong New District
Shanghai, China 201206
Phone: +86 21 3418 5200

Danfoss can accept no responsibility for possible errors in catalogues, brochures and other printed material. Danfoss reserves the right to alter its products without notice. This also applies to products already on order provided that such alterations can be made without changes being necessary in specifications already agreed. All trademarks in this material are property of the respective companies. Danfoss and the Danfoss logotype are trademarks of Danfoss A/S. All rights reserved.