

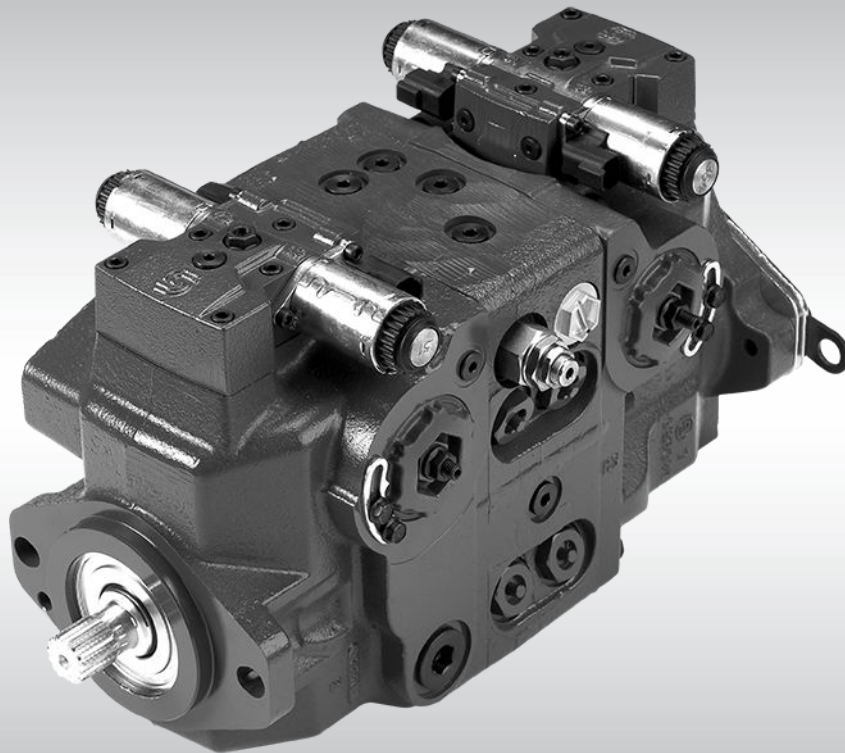

Technical Information

H1 Axial Piston Tandem Pumps

Size 045/053



Revision history*Table of revisions*

Date	Changed	Rev
November 2015	Master Model Code changes	0500
September 2014	MDC, CCO, and Swash Angle Sensor options added	EA
Apr 2014	Converted to Danfoss layout - DITA CMS	DA
Dec 2012	Various changes	CA
Jul 2010	New EC directive	BA
Jul 2009	First edition	AA

Contents
Technical specifications

H1T general specifications.....	5
Technical data H1T 045/053 Tandem.....	5
Operating parameters H1T 045/053 Tandem.....	6
Fluid specifications H1P	6
External radial shaft loads H1T 045/053 Tandem.....	7
Bearing life H1 045/053.....	7
Mounting flange loads H1T 045/053 Tandem.....	8
Charge pump.....	9
Charge pump sizing/selection.....	9
Integrated charge pump option.....	9
Charge pump flow and power curves, 24 cm ³	9
Case drain.....	10

Master model code H1P 045/053 Tandem
Control options

Electrical Displacement Control (EDC), options: A2 (12 V) / A3 (24 V).....	15
EDC control signal requirements.....	15
EDC solenoid data, 045/53 Tandem.....	16
Control response.....	16
Response time, EDC 045/053.....	17
Manual Displacement Control (MDC)	18
MDC principle.....	18
MDC general information.....	19
Shaft rotation MDC.....	19
Control response.....	19
Response time, MDC 045/053.....	20
Neutral Start Switch (NSS).....	20
Case gauge port M14.....	21
Lever.....	21
Forward-Neutral-Reverse (FNR), options: A9 (12 V) / B1 (24 V) Tandem.....	22
Control response.....	23
Response time, FNR 045/053.....	23
Non Feedback Proportional Electric Control (NFPE), options: A8 (12 V) / B8 (24 V).....	24
Control signal requirements, NFPE 045/053 Tandem.....	24
Control response.....	25
Response time, NFPE 045/053.....	26
Manual Over Ride (MOR).....	27
Control-Cut-Off valve (CCO) for tandem pump.....	27
Displacement limiter.....	29
Displacement change (approximately) H1P 045/053 Single.....	29

Dimensions

Ports description H1P 045/053 Tandem.....	30
Dimensions H1T 045/053 Tandem.....	32
H1T input shaft, option G1 (SAE B, 14 teeth).....	35
H1T input shaft, option G5 (SAE B-B, 15 teeth).....	36
H1T input shaft, option F2, Code 25-3.....	37
Tapered shaft customer acknowledgement.....	37
External charge pump mounting options	38
Auxiliary mounting pads without charge pump	39
H1T Auxiliary mounting, option H2 (SAE A, 9 teeth).....	39
H1T Auxiliary mounting, option H1 (SAE A, 11 teeth)	40
H1T Auxiliary mounting, option H3 (SAE B, 13 teeth).....	41
H1T Auxiliary mounting, option H5 (SAE B-B, 15 teeth).....	42
Auxiliary mounting pads with external charge pump.....	43
Option T2 (SAE A, 9 teeth)	43
Option T1 (SAE A, 11 teeth)	44
Option T3 (SAE B, 13 teeth)	45
Electric Displacement Control (EDC), option A2 (12V) / A3 (24V) H1T 045/053.....	46

Contents

Electric Displacement Control (EDC) with MOR, option A4 (12 V) / A5 (24 V) H1T 045/053.....	46
Manual Displacement Control (MDC), option M1, H1T 045/053.....	47
Manual Displacement Control (MDC) with NSS, option M2, H1T 045/053.....	48
Manual Displacement Control (MDC) with NSS, option 09, H1T 045/053.....	49
Forward-Neutral-Reverse (FNR) with MOR, option A9 (12 V) / B1 (24 V) H1T 045/053.....	50
Non Feedback Proportional Electric Control (NFPE) with MOR, option A8 (12 V) B8 (24V) H1T 045/053.....	51
Center section coupling, torque rating.....	51
Control Cut Off (CCO) H1T 045/053.....	52
H1T displacement limiter, 045/053 Tandem, option B.....	53

Technical Information H1 Axial Piston Tandem Pumps, Size 045/053

Technical specifications

For definitions of the following specifications, see *H1 Axial Piston Pumps, Basic Information 11062168*, chapter *Operating parameters*.

H1T general specifications

Design	Axial piston pump of cradle swashplate design with variable displacement
Direction of rotation	Clockwise, counterclockwise
Pipe connections	<i>Main pressure ports:</i> SAE straight thread O-ring boss <i>Remaining ports:</i> SAE straight thread O-ring boss
Recommended installation position	Pump installation position is discretionary, however the recommended control position is on the top or at the side, with the top position preferred. If the pump is installed with the control at the bottom, flushing flow must be provided through port M14 located on the EDC and FNR control. Vertical input shaft installation is acceptable. The housing must always be filled with hydraulic fluid. Recommended mounting for a multiple pump stack is to arrange the highest power flow towards the input source. Consult Danfoss for nonconformance to these guidelines.
Auxiliary cavity pressure	Will be inlet pressure with the charge pump option. For reference see operating parameters on next page. Will be case pressure with external charge supply. Please verify mating pump shaft seal capability.

Technical data H1T 045/053 Tandem

Feature	Size 045	Size 053
Displacement	45.0 cm ³ [2.75 in ³]	53.8 cm ³ [3.28 in ³]
Flow at rated (continuous) speed*	153 l/min [40 US gal/min]	183 l/min [48 US gal/min]
Torque at maximum displacement (theoretical)	0.8 N·m/bar [488 lbf·in/1000 psi]	0.9 N·m/bar [549 lbf·in/1000 psi]
Mass moment of inertia of rotating components	0.0078 kg·m ² [0.00575 slug·ft ²]	0.0077 kg·m ² [0.00568 slug·ft ²]
Mass [weight] dry	65 kg [143 lb] (without charge pump or auxiliary mounting flange)	
Oil volume	2.3 l [0.61 US gal]	
Mounting flange	ISO 3019-1 flange 101-2 (SAE B), Special bolt diameter	
Input shaft outer diameter, splines and tapered shafts	ISO 3019-1, outer Ø25 mm - 4 (SAE B-B, 15 teeth) ISO 3019-1, outer Ø32 mm - 4 (SAE-B, 14 teeth) Conical keyed shaft end similar to ISO 3019-1 code 25-3, taper 1:8	
Auxiliary mounting flange with metric fasteners, Shaft outer diameter and splines	ISO 3019-1, flange 82 - 2, outer Ø16 mm - 4 (SAE A, 9 teeth) ISO 3019-1, flange 82 - 2, outer Ø19 mm - 4 (SAE A, 11 teeth) ISO 3019-1, flange 101 - 2, outer Ø22 mm - 4 (SAE B, 13 teeth) ISO 3019-1, flange 101 - 2, outer Ø25 mm - 4 (SAE B-B, 15 teeth)**	
Charge inlet port	Port ISO 11926-1 – 1 7/8 -14 (SAE O-ring boss)	
Charge pump option	Inlet port: ISO 11926-1 – 1 5/8 -12 (SAE O-ring boss) Outlet port: ISO 11926-1 – 1 1/16 -12 (SAE O-ring boss)	
Main port configuration	ISO 11926-1 – 1 5/16 -12 (SAE O-ring boss)	
Case drain port L3 (use for cooling purposes)	Port ISO 11926-1 – 1 1/16 -12 (SAE O-ring boss)	
Other ports	SAE O-ring boss	
Customer interface threads	Metric fasteners	

* Applies for each rotating group

** Not available with the tandem charge pump option

Technical specifications
Operating parameters H1T 045/053 Tandem

Feature		Size 045	Size 053
Input speed (at minimum charge/ control pressure)	Minimum for internal charge supply¹⁾	500 min ⁻¹ (rpm)	
	Minimum for external charge supply²⁾	500 min ⁻¹ (rpm)	
	Minimum for full performance for internal charge supply	1275	1350
	Rated	3400 min ⁻¹ (rpm)	
	Maximum	3500 min ⁻¹ (rpm)	
System pressure	Maximum working pressure	420 bar [6090 psi]	380 bar [5510 psi]
	Maximum pressure	450 bar [6527 psi]	400 bar [5800 psi]
	Maximum low loop	45 bar [650 psi]	
	Minimum low loop pressure	10 bar [145 psi]	
Charge pressure	Minimum without CCO (Control Cut Off) valve	16 bar [232 psi]	
	Minimum with CCO (Control Cut Off) valve	18 bar [265 psi]	
	Maximum	30 bar [435 psi]	
Control pressure	Minimum (at corner power for EDC, MDC, FNR)	21.5 bar [312 psi]	
	Maximum	40 bar [580 psi]	
Case pressure	Rated	3 bar [44 psi]	
	Maximum	5 bar [73 psi]	
Lip seal external maximum pressure		0.4 [5.8 psi]	

¹⁾ Performance (pressure and displacement) may be limited due to limited control pressure.

²⁾ Full performance (pressure and displacement) possible at minimum charge and control pressure supply.

Fluid specifications H1P
Viscosity and temperature range

Feature		Unit	Data
Viscosity	Intermittent¹⁾	mm ² /s [SUS]	5 [42]
	Minimum		7 [49]
	Recommended range		12 – 80 [66 – 370]
	Maximum		1600 [7500]
Temperature range²⁾	Minimum³⁾ (cold start)	°C [°F]	-40 [-40]
	Recommended range		60 – 85 [140 – 185]
	Rated		104 [220]
	Maximum intermittent¹⁾		115 [240]

¹⁾ Intermittent = Short term t < 1 min per incident and not exceeding 2 % of duty cycle based load-life

²⁾ At the hottest point, normally case drain port

³⁾ Cold start = Short term t < 3min, p ≤ 50 bar [725 psi], n ≤ 1000 min⁻¹(rpm)

Filtration, cleanliness level and β_x-ratio (recommended minimum)

Cleanliness per ISO 4406	22/18/13
Efficiency β_x (charge pressure filtration)	β ₁₅₋₂₀ = 75 (β ₁₀ ≥ 10)

Technical specifications
Filtration, cleanliness level and β_x -ratio (recommended minimum) (continued)

Efficiency β_x (suction and return line filtration)	$\beta_{35-45} = 75$ ($\beta_{10} \geq 2$)
Recommended inlet screen mesh size	100 – 125 μm

External radial shaft loads H1T 045/053 Tandem
External radial shaft loads

H1 pumps are designed with bearings that can accept some external radial loads. The external radial shaft load limits are a function of the load position and orientation, and the operating conditions of the unit. External radial shaft loads impact lifetime. For lifetime calculations please contact Danfoss representative.

The **maximum allowable radial load (R_e)** is based on the maximum external moment (M_e) and the distance (L) from the mounting flange to the load.

It may be determined using the following formula:
$$R_e = \frac{M_e}{L}$$

Radial load position

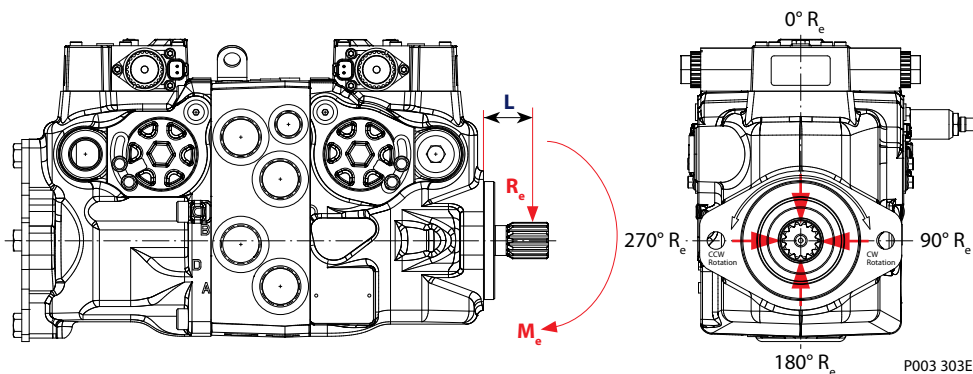

M_e = shaft moment

L = flange distance

R_e = external force to the shaft

Thrust loads should be avoided. Contact factory in the event thrust loads are anticipated.

Bearing life H1 045/053

Maximum external shaft load based on shaft deflection

External radial moment	Unit	Size 045 / 053
M_e	N·m [lbf·in]	TBD

All external shaft loads affect bearing life. In applications with external shaft loads, minimize the impact by positioning the load at 0° or 180° as shown in the figure.

Danfoss recommends clamp-type couplings for applications with radial shaft loads.

Contact your Danfoss representative for an evaluation of unit bearing life if you have continuously applied external loads exceeding 25 % of the maximum allowable radial load (R_e) or the pump swashplate is positioned on one side of center all or most of the time.

Technical specifications

Mounting flange loads H1T 045/053 Tandem

H1 tandem pump front flange load

Mounting flange loads H1T 045/053, Controls on top

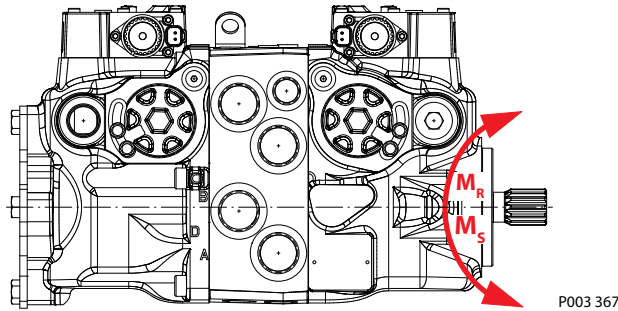

The moments shown below apply for the control orientation on top or side.

Mounting flange loads, Control on top

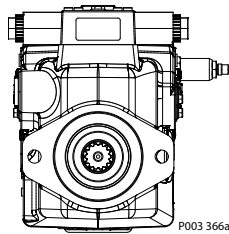

Rated moment:
 $M_R = 2020 \text{ N}\cdot\text{m}$ [17 880 lbf·in]

Shock load moment:
 $M_S = 4110 \text{ N}\cdot\text{m}$ [36 380 lbf·in]

Mounting flange loads, Control on side

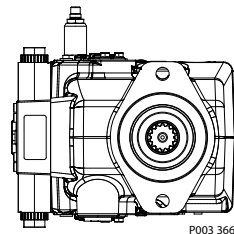

Rated moment:
 $M_R = 1300 \text{ N}\cdot\text{m}$ [11 510 lbf·in]

Shock load moment:
 $M_S = 2930 \text{ N}\cdot\text{m}$ [25 935 lbf·in]

For more information, see *H1 Axial Piston Pumps, Basic Information 11062168*, the section "Mounting flange loads".

Mounting flange load external charge pump

Mounting flange load external charge pump

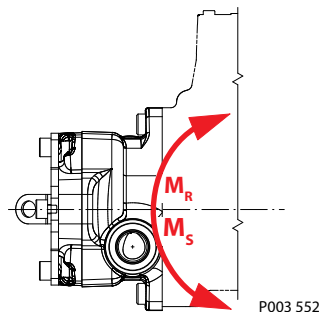

Rated moment:
 $M_R = 520 \text{ N}\cdot\text{m}$ [4600 lbf·in]

Shock load moment:
 $M_S = 1300 \text{ N}\cdot\text{m}$ [11 500 lbf·in]

For more information, see *H1 Axial Piston Pumps, Basic Information 11062168*, the section "Mounting flange loads".

Technical specifications
Charge pump
Charge pump sizing/selection

In most applications a general guideline is that the charge pump displacement should be at least 10% of the total displacement of all components in the system. Unusual application conditions may require a more detailed review of charge flow requirements. Please refer to *Selection of Drive line Components, BLN-9885* for a detailed procedure.

System features and conditions which may invalidate the 10% guideline include (but are not limited to):

- Continuous operation at low input speeds {< 1500 min⁻¹ (rpm)}
- High shock loading and/or long loop lines
- High flushing flow requirements
- Multiple low speed high torque motors
- High input shaft speeds

Contact your Danfoss Power Solutions representative for application assistance if your application includes any of these conditions.

Integrated charge pump option

The tandem pumps are available with an optional gerotor module bolted onto the back of the rear pump as show in the figures below. The charge pump is available with SAE A or B auxiliary pads or a no-pad option. The orientation of the charge pump can be specified in one of the configurations shown.

Charge pump flow and power curves, 24 cm³

Charge pressure: 20 bar [290 psi] / Viscosity: 11 mm²/s [63 SUS] / Temperature: 80°C [176°F]

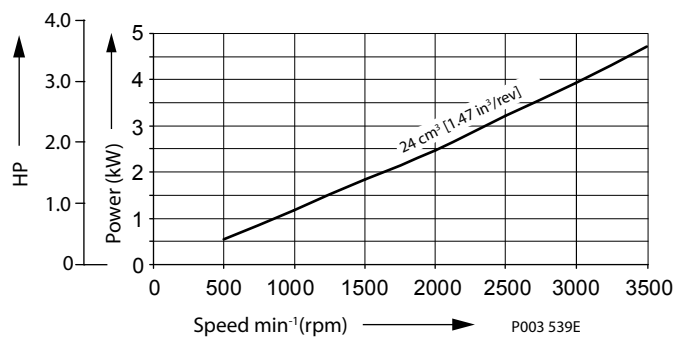
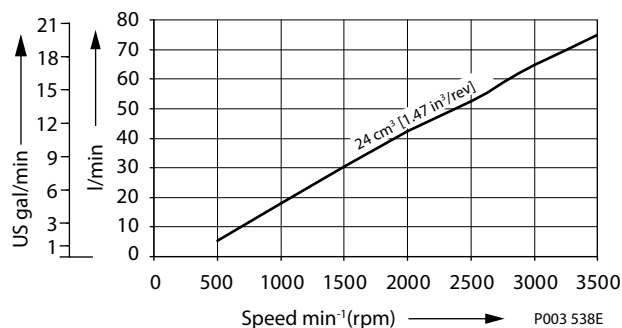
Charge pump power requirements

Charge pump flow

Technical specifications**Case drain**

The tandem housings are connected through the center section via a drilled hole. The charge relief valve discharges oil into the front housing. In order to provide positive flow through both housings, use of the rear housing case drain is required. The front housing case pressure ports should only be used if the pump is used as a common drain manifold for the vehicle where external drain flow is brought into the rear housing and discharged out the front.

[The allowable case pressures must be met accordingly.](#)

Technical Information H1 Axial Piston Tandem Pumps, Size 045/053

Master model code H1P 045/053 Tandem



K – Auxiliary mounting pad ISO 3019-1 (Align with options S: Charge pump and Y: Special settings)

Without charge pump	
NN	No auxiliary mounting pad
H2	Flange 82 - 2, outer Ø16 mm - 4 (SAE A, 9 teeth 16/32 coupling)
H1	Flange 82 - 2, outer Ø19 mm - 4 (SAE A, 11 teeth 16/32 coupling)
H3	Flange 101 - 2, outer Ø22 mm - 4 (SAE B, 13 teeth 16/32 coupling)
H5	Flange 101 - 2, outer Ø25 mm - 4 (SAE B-B, 15 teeth 16/32 coupling)
Shipping cover	
With charge pump	
TN	No auxiliary mounting pad
T2	Flange 82 - 2, outer Ø16 mm - 4 (SAE A, 9 teeth 16/32 coupling)
T1	Flange 82 - 2, outer Ø19 mm - 4 (SAE A, 11 teeth 16/32 coupling)
T3	Flange 101 - 2, outer Ø22 mm - 4 (SAE B, 13 teeth 16/32 coupling)
Shipping cover	

M – High pressure relief valve setting, NO bypass, side “A” (front pump)

N – High pressure relief valve setting, NO bypass side “B” (front pump)

P – High pressure relief valve setting, NO bypass, side “C” (rear pump)

R – High pressure relief valve setting, NO bypass, side “D” (rear pump)

Code	Pressure setting (Use the selection for ports A, B, C and D)	045	053
18	180 bar [2610 psi]	●	●
20	200 bar [2900 psi]	●	●
23	230 bar [3336 psi]	●	●
25	250 bar [3630 psi]	●	●
28	280 bar [4061 psi]	●	●
30	300 bar [4350 psi]	●	●
33	330 bar [4786 psi]	●	●
35	350 bar [5080 psi]	●	●
38	380 bar [5510 psi]	●	●
40	400 bar [5800 psi]	●	–
42	420 bar [6090 psi]	●	–

● = available option,

– = not available option

S – Charge pump

M	24 cm ³ /rev [1.46 in ³ /rev]
N	No charge pump, external charge supply (Align with options: E – Displ. Limiters, T – Filtration)

T – Filtration

P	Remote full charge flow filtration
----------	------------------------------------

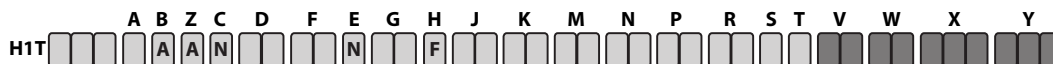
Master model code H1P 045/053 Tandem

V – Charge pressure relief setting

20	20 bar [290 psi]	<u>Not to be used for NFPE and AC controls.</u>
22	22 bar [319 psi]	
24	24 bar [348 psi]	
26	26 bar [377 psi]	
28	28 bar [406 psi]	
32	32 bar [464 psi]	
34	34 bar [493 psi]	

W – Special hardware features

PN	EDC / FNR / MDC valve plate
P1	NFPE valve plate (<i>Align with options: D – Control selection and E – Displacement limiters</i>)

X – Paint and nametag

NNN	Black paint and Danfoss nametag
------------	---------------------------------

Y – Special settings

NNN	None	<i>Align with options:</i> K – Auxiliary mounting pad and S – Charge pump
S01	Charge pump orientation at 0°	
S02	Charge pump orientation at 180°	
M00	MDC Handle standard position	

Control options

Electrical Displacement Control (EDC), options: A2 (12 V) / A3 (24 V)

The **Electrical Displacement Control (EDC)** consists of a pair of proportional solenoids on each side of a three-position, four-way porting spool. The proportional solenoid applies a force input to the spool, which ports hydraulic pressure to either side of a double acting servo piston. Differential pressure across the servo piston rotates the swashplate, changing the pump's displacement from full displacement in one direction to full displacement in the opposite direction.

Under some circumstances, such as contamination, the control spool could stick and cause the pump to stay at some displacement. A serviceable 125 µm screen is located in the supply line immediately before the control porting spool.

Electrical Displacement Control

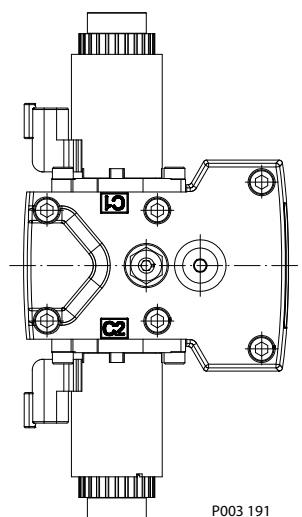

EDC schematic

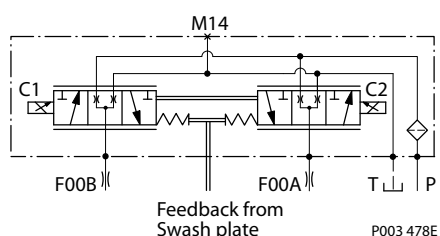

Pump displacement vs. control current

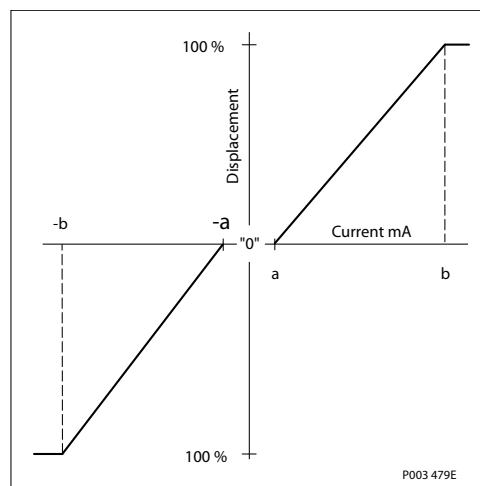

EDC control signal requirements

Control minimum current to stroke pump

Voltage	a*	b	Pin connections
12 V	640 mA	1640 mA	any order
24 V	330 mA	820 mA	

* Factory test current, for vehicle movement or application actuation expect higher or lower value.

Connector

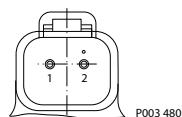

Control options
Connector ordering data

Description	Quantity	Ordering number
Mating connector	1	Deutsch® DT06-2S
Wedge lock	1	Deutsch® W2S
Socket contact (16 and 18 AWG)	2	Deutsch® 0462-201-16141
Danfoss mating connector kit	1	K29657

EDC solenoid data, 045/53 Tandem
Solenoid data

Description		12 V	24 V
Maximum current		1800 mA	920 mA
Nominal coil resistance	@ 20 °C [68 °F]	3.66 Ω	14.20 Ω
	@ 80 °C [176 °F]	4.52 Ω	17.52 Ω
Inductance		33 mH	140 mH
PWM	Range	70-200 Hz	
	Frequency (preferred)*	100 Hz	
IP Rating	IEC 60 529	IP 67	
	DIN 40 050, part 9	IP 69K with mating connector	

* PWM signal required for optimum control performance.

Pump output flow direction vs. control signal

Shaft rotation	CW				CCW			
	Front		Rear		Front		Rear	
Coil energized*	C2	C1	C2	C1	C2	C1	C2	C1
Port A	in	out	—	—	out	in	—	—
Port B	out	in	—	—	in	out	—	—
Port C	—	—	in	out	—	—	out	in
Port D	—	—	out	in	—	—	in	out
Servo port pressurized	M5	M4	M5	M4	M5	M4	M5	M4

* For coil location see Installation drawings.

Control response

H1 controls are available with optional control passage orifices to assist in matching the rate of swashplate response to the application requirements (e.g. in the event of electrical failure). The time required for the pump output flow to change from zero to full flow (acceleration) or full flow to zero (deceleration) is a net function of spool porting, orifices, and charge pressure. A swashplate response table is available for each frame indicating available swashplate response times. Testing should be conducted to verify the proper orifice selection for the desired response.

[H1 pumps are limited in mechanical orificing combinations. Mechanical servo orifices are to be used only for fail-safe return to neutral in the event of an electrical failure.](#)

Technical Information H1 Axial Piston Tandem Pumps, Size 045/053

Control options

Typical response times shown below at the following conditions:

Δp	250 bar [3626 psi]
Viscosity and temperature	30 mm ² /s [141 SUS] and 50 °C [122 °F]
Charge pressure	20 bar [290 psi]
Speed	1800 min ⁻¹ (rpm)

Response time, EDC 045/053

Stroking direction	0.8 mm [0.03 in] orifice	1.3 mm [0.05 in] orifice	No orifice
Neutral to full flow	1.7 s	0.9 s	0.5 s
Full flow to neutral	1.1 s	0.6 s	0.3 s

Control options
Manual Displacement Control (MDC)
MDC principle

An MDC is a Manual proportional Displacement Control (MDC). The MDC consists of a handle on top of a rotary input shaft. The shaft provides an eccentric connection to a feedback link. This link is connected on its one end with a porting spool. On its other end the link is connected the pumps swashplate.

This design provides a travel feedback without spring. When turning the shaft the spool moves thus providing hydraulic pressure to either side of a double acting servo piston of the pump.

Differential pressure across the servo piston rotates the swash plate, changing the pump's displacement. Simultaneously the swashplate movement is fed back to the control spool providing proportionality between shaft rotation on the control and swashplate rotation.

The MDC changes the pump displacement between no flow and full flow into opposite directions. Under some circumstances, such as contamination, the control spool could stick and cause the pump to stay at some displacement.

A serviceable 125 µm screen is located in the supply line immediately before the control porting spool.

The MDC is sealed by means of a static O-ring between the actuation system and the control block. Its shaft is sealed by means of a special O-ring which is applied for low friction. The special O-ring is protected from dust, water and aggressive liquids or gases by means of a special lip seal.

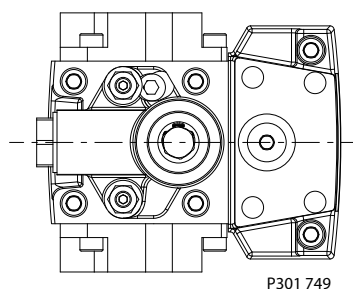
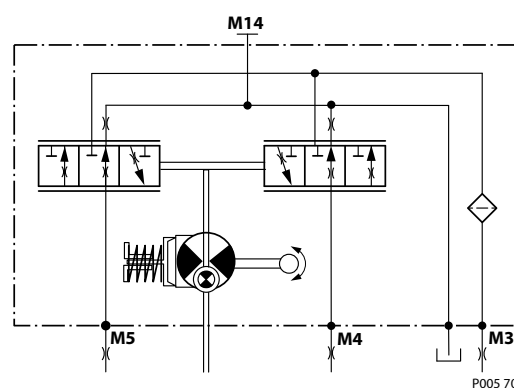
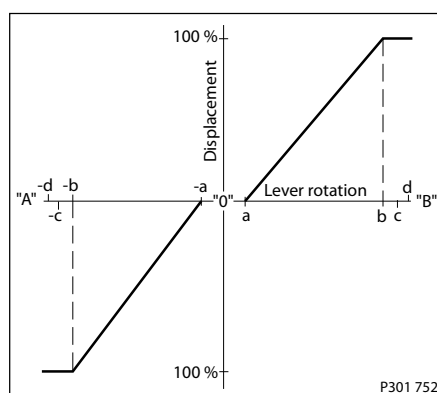
Manual Displacement Control on H1 pump

MDC schematic diagram

Pump displacement vs. control lever rotation

Where:

- Deadband on **B** side – $a = 3^\circ \pm 1^\circ$
- Maximum pump stroke – $b = 30^\circ +2/-1^\circ$
- Required customer end stop – $c = 36^\circ \pm 3^\circ$
- Internal end stop – $d = 40^\circ$

Volumetric efficiencies of the system will have impacts on the start and end input commands.

MDC torque

Torque required to move handle to maximum displacement	1.4 N·m [12.39 lbf·in]
Torque required to hold handle at given displacement	0.6 N·m [5.31 lbf·in]
Maximum allowable input torque	20 N·m [177 lbf·in]

Control options
MDC general information

In difference to other controls the MDC provides a mechanical deadband. This is required to overcome the tolerances in the mechanical actuation.

The MDC contains an internal end stop to prevent over travel. The restoring moment is appropriate for turning the MDC input shaft back to neutral only. Any linkages or cables may prevent the MDC from returning to neutral.

The MDC is designed for a maximum case pressure of 5 bar and a rated case pressure of 3 bar. If the case pressure exceeds 5 bar there is a risk of an insufficient restoring moment. In addition a high case pressure can cause the NSS to indicate that the control is not in neutral. High case pressure may cause excessive wear.

Customers can apply their own handle design but they must care about a robust clamping connection between their handle and the control shaft and avoid overload of the shaft.

Customers can connect two MDC's on a tandem unit in such a way that the actuation force will be transferred from the pilot control to the second control but the kinematic of the linkages must ensure that either control shaft is protected from torque overload.

To avoid an overload of the MDC, customers must install any support to limit the setting range of the Bowden cable.

Caution

Using the internal spring force on the input shaft is not an appropriate way to return the customer connection linkage to neutral.

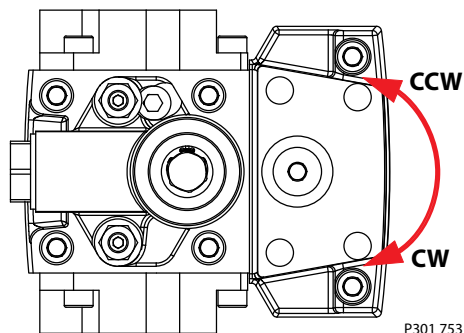
Shaft rotation MDC

MDC shaft rotation data

Pump shaft rotation*	Clock Wise (CW)		Counter Clock Wise (CCW)	
	CW	CCW	CW	CCW
Port A	in (low)	out (high)	out (high)	in (low)
Port B	out (high)	in (low)	in (low)	out (high)
Servo port high pressure	M5	M4	M5	M4

* As seen from shaft side.

Control response

H1 controls are available with optional control passage orifices to assist in matching the rate of swashplate response to the application requirements (e.g. in the event of electrical failure). The time required for the pump output flow to change from zero to full flow (acceleration) or full flow to zero (deceleration) is a net function of spool porting, orifices, and charge pressure. A swashplate response table is available for each frame indicating available swashplate response times. Testing should be conducted to verify the proper orifice selection for the desired response.

Control options

H1 pumps are limited in mechanical orificing combinations. Mechanical servo orifices are to be used only for fail-safe return to neutral in the event of an electrical failure.

Typical response times shown below at the following conditions:

Ap	250 bar [3626 psi]
Viscosity and temperature	30 mm ² /s [141 SUS] and 50 °C [122 °F]
Charge pressure	20 bar [290 psi]
Speed	1800 min ⁻¹ (rpm)

Response time, MDC 045/053

Code	Orifice description (mm)				Stroking direction (sec)	
	P	A	B	Tank (A+B)	Neutral to full flow	Full flow to neutral
C3	–	–	–	–	0.3	0.4
C6	–	–	–	1	0.9	0.8
C7	–	–	–	1.3	0.6	0.6
C8	0.8	–	–	0.6	2.9	2.0
C9	1	–	–	0.6	2.7	1.9
D1	1	–	–	0.8	1.7	1.2
D2	1.3	–	–	0.8	1.5	1.1
D3	1.3	–	–	1	1.1	0.8
D4	1.3	1.3	1.3	1	1.3	1.0
D5	0.6	0.8	0.8	0.6	5.4	2.8

Neutral Start Switch (NSS)

The Neutral Start Switch (NSS) contains an electrical switch that provides a signal of whether the control is in neutral. The signal in neutral is **Normally Closed (NC)**.

Neutral Start Switch schematic

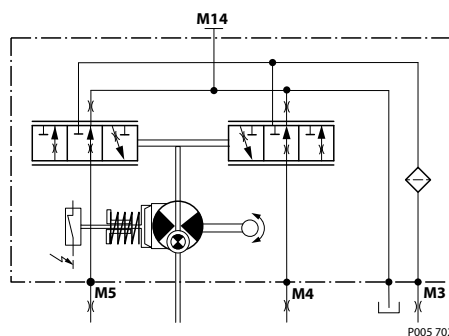

Neutral Start Switch data

Max. continuous current with switching	8.4 A
Max. continuous current without switching	20 A
Max. voltage	36 V _{DC}
Electrical protection class	IP67 / IP69K with mating connector

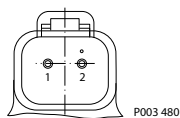
Control options
Connector

Connector ordering data

Description	Quantity	Ordering number
Mating connector	1	Deutsch® DT06-2S
Wedge lock	1	Deutsch® W2S
Socket contact (16 and 18 AWG)	2	Deutsch® 0462-201-16141
Danfoss mating connector kit	1	K29657

Case gauge port M14

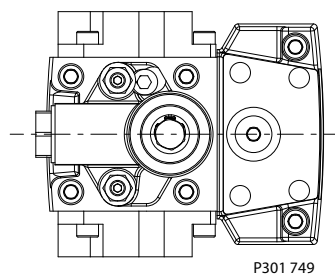
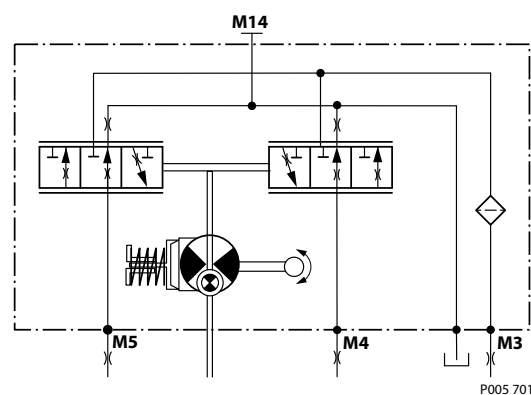
The drain port should be used when the control is mounted on the unit's bottom side to flush residual contamination out of the control.

MDC w/h drain port shown

MDC schematic diagram

Lever

MDC-controls are available with an integrated lever.

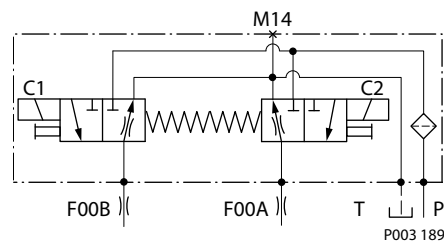
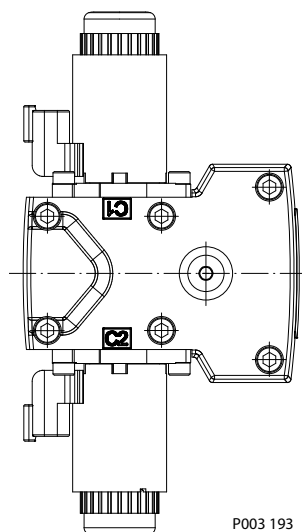
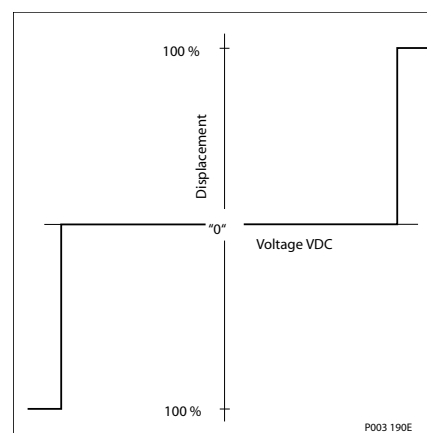
Control options
Forward-Neutral-Reverse (FNR), options: A9 (12 V) / B1 (24 V) Tandem

The 3-position **FNR** control uses an electric input signal to switch the pump to a full stroke position. Under some circumstances, such as contamination, the control spool could stick and cause the pump to stay at some displacement. A serviceable 125 µm screen is located in the supply line immediately before the control porting spool.

Forward-Neutral-Reverse electric control (FNR) FNR hydraulic schematic

Pump displacement vs. electrical signal

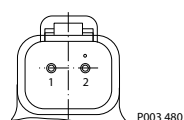
Control current

Voltage	Min. current to stroke pump	Pin connections
12 V	750 mA	any order
24 V	380 mA	

Connector

Connector ordering data

Description	Quantity	Ordering number
Mating connector	1	Deutsch® DT06-2S
Wedge lock	1	Deutsch® W2S
Socket contact (16 and 18 AWG)	2	Deutsch® 0462-201-16141
Danfoss mating connector kit	1	K29657

Control options
Solenoid data

Voltage	12 V	24 V
Minimum supply voltage	9.5 V _{DC}	19.0 V _{DC}
Maximum supply voltage (continuous)	14.6 V _{DC}	29.0 V _{DC}
Maximum current	1050 mA	500 mA
Nominal coil resistance @ 20 °C [70 °F]	8.4 Ω	34.5 Ω
PWM Range	70-200 Hz	
PWM Frequency (preferred)*	100 Hz	
IP Rating (IEC 60 529) + DIN 40 050, part 9	IP 67 / IP 69K with mating connector	

* PWM signal required for optimum control performance.

Pump output flow direction vs. control signal

Shaft rotation	CW				CCW			
	Front		Rear		Front		Rear	
Coil energized*	C1	C2	C1	C2	C1	C2	C1	C2
Port A	in	out	—	—	out	in	—	—
Port B	out	in	—	—	in	out	—	—
Port C	—	—	in	out	—	—	out	in
Port D	—	—	out	in	—	—	in	out
Servo port pressurized	M5	M4	M5	M4	M5	M4	M5	M4

* For coil location see installation drawings.

Control response

H1 controls are available with optional control passage orifices to assist in matching the rate of swashplate response to the application requirements (e.g. in the event of electrical failure). The time required for the pump output flow to change from zero to full flow (acceleration) or full flow to zero (deceleration) is a net function of spool porting, orifices, and charge pressure. A swashplate response table is available for each frame indicating available swashplate response times. Testing should be conducted to verify the proper orifice selection for the desired response.

H1 pumps are limited in mechanical orificing combinations. Mechanical servo orifices are to be used only for fail-safe return to neutral in the event of an electrical failure.

Typical response times shown below at the following conditions:

Δp	250 bar [3626 psi]
Viscosity and temperature	30 mm ² /s [141 SUS] and 50 °C [122 °F]
Charge pressure	20 bar [290 psi]
Speed	1800 min ⁻¹ (rpm)

Response time, FNR 045/053

Stroking direction	0.8 mm [0.03 in] Orifice	1.3 mm [0.05 in] Orifice	No orifice
Neutral to full flow	1.8 s	0.9 s	0.5 s
Full flow to neutral	1.6 s	0.8 s	0.4 s

Control options

Non Feedback Proportional Electric Control (NFPE), options: A8 (12 V) / B8 (24 V)

The **Non Feedback Proportional Electric (NFPE)** control is an electrical automotive control in which an electrical input signal activates one of two proportional solenoids that port charge pressure to either side of the pump servo cylinder.

The NFPE control has no mechanical feedback mechanism. The pump displacement is proportional to the solenoid signal current, but it also depends upon pump input speed and system pressure. This characteristic also provides a power limiting function by reducing the pump swashplate angle as system pressure increases.

A typical response characteristic is shown in *the accompanying graph*. Under some circumstances, such as contamination, the control spool could stick and cause the pump to stay at some displacement.

A serviceable 125 μm screen is located in the supply line immediately before the control porting spool.

NFPE Control

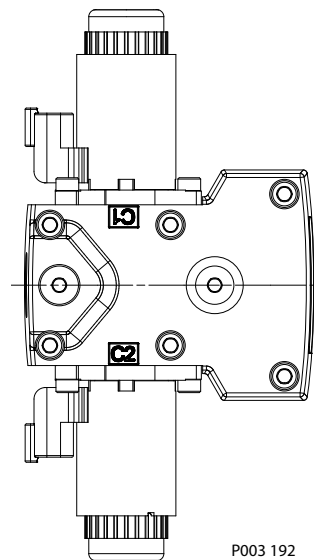

NFPE schematic

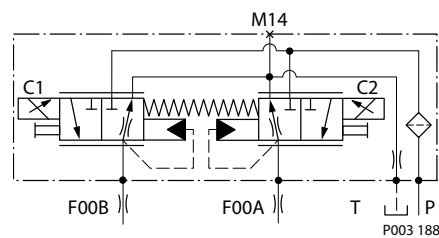

Pump displacement vs. input signal

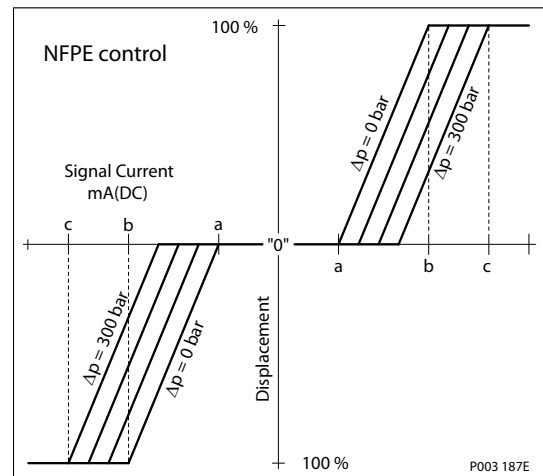

Control signal requirements, NFPE 045/053 Tandem

Control current

Voltage	a* mA	b mA	c mA	Pin connections
12 V	870	1290	1550	any order
24 V	440	670	775	

* Factory test current, for vehicle movement or application actuation expect higher or lower value.

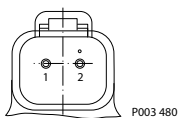
Control options
Connector

Connector ordering data

Description	Quantity	Ordering number
Mating connector	1	Deutsch® DT06-2S
Wedge lock	1	Deutsch® W2S
Socket contact (16 and 18 AWG)	2	Deutsch® 0462-201-16141
Danfoss mating connector kit	1	K29657

Solenoid data

Description		12 V	24 V
Maximum current		1800 mA	920 mA
Nominal coil resistance	@ 20 °C [68 °F]	3.66 Ω	14.20 Ω
	@ 80 °C [176 °F]	4.52 Ω	17.52 Ω
Inductance		33 mH	140 mH
PWM	Range	70-200 Hz	
	Frequency (preferred)*	100 Hz	
IP Rating	IEC 60 529	IP 67	
	DIN 40 050, part 9	IP 69K with mating connector	

* PWM signal required for optimum control performance.

Pump output flow direction vs. control signal

Shaft rotation	CW		CCW	
	C1	C2	C1	C2
Coil energized*				
Port A	in	out	out	in
Port B	out	in	in	out
Servo port pressurized	M5	M4	M5	M4

* For coil location see Installation drawings.

Control response

H1 controls are available with optional control passage orifices to assist in matching the rate of swashplate response to the application requirements (e.g. in the event of electrical failure). The time required for the pump output flow to change from zero to full flow (acceleration) or full flow to zero (deceleration) is a net function of spool porting, orifices, and charge pressure. A swashplate response table is available for each frame indicating available swashplate response times. Testing should be conducted to verify the proper orifice selection for the desired response.

H1 pumps are limited in mechanical orificing combinations. Mechanical servo orifices are to be used only for fail-safe return to neutral in the event of an electrical failure.

Technical Information H1 Axial Piston Tandem Pumps, Size 045/053

Control options

Typical response times shown below at the following conditions:

Δp	250 bar [3626 psi]
Viscosity and temperature	30 mm ² /s [141 SUS] and 50 °C [122 °F]
Charge pressure	20 bar [290 psi]
Speed	1800 min ⁻¹ (rpm)

Response time, NFPE 045/053

Stroking direction	0.8 mm [0.03 in] orifice	1.3 mm [0.05 in] orifice	No orifice
Neutral to full flow	3.1 s	1.4 s	0.8 s
Full flow to neutral	2.0 s	0.9 s	0.4 s

Control options
Manual Over Ride (MOR)

All controls are available with a Manual Over Ride (MOR) either standard or as an option for temporary actuation of the control to aid in diagnostics.

Forward-Neutral-Reverse (FNR) and Non Feedback Proportional Electric (NFPE) controls are always supplied with MOR functionality.

Manual Over Ride (MOR)

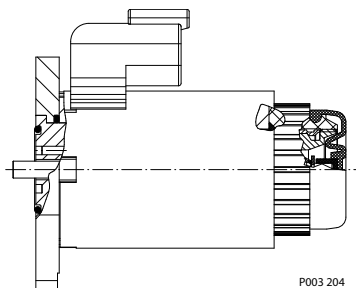

MOR schematic diagram (EDC shown)

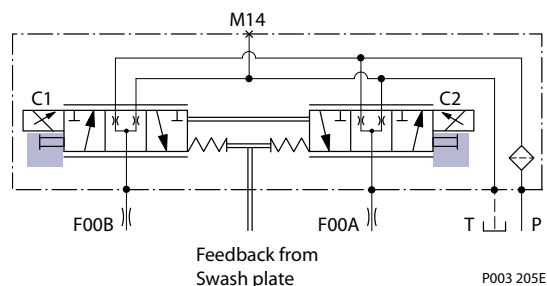

Unintended MOR operation will cause the pump to go into stroke. The vehicle or device must always be in a „safe“ condition (i.e. vehicle lifted off the ground) when using the MOR function.

The MOR plunger has a 4 mm diameter and must be manually depressed to be engaged. Depressing the plunger mechanically moves the control spool which allows the pump to go on stroke.

The MOR should be engaged anticipating a full stroke response from the pump.

⚠ Warning

An o-ring seal is used to seal the MOR plunger where initial actuation of the function will require a force of 45 N to engage the plunger. Additional actuations typically require less force to engage the MOR plunger. Proportional control of the pump using the MOR should not be expected.

Refer to control flow table for the relationship of solenoid to direction of flow.

Control-Cut-Off valve (CCO) for tandem pump

The H1 tandem pump offers an optional control cut off valve integrated into the pump center section. This valve will block charge pressure from the servos in both pumps, allowing the servo springs to de-stroke both pumps regardless of the pump’s primary control input. There is also a hydraulic logic port, X7, which can be used to control other machine functions, such as spring applied pressure release brakes. The pressure at X7 is controlled by the control cut off solenoid. The control cut off option can be used with or without the use of the X7 logic port. The X7 port would remain plugged if not needed.

In the normal (de-energized) state of the solenoid charge flow is prevented from reaching the controls. At the same time the control passages and the X7 logic port are connected and drained to the pump case. The pump will remain in neutral, or return to neutral, independent of the control input signal. Return to neutral times will be dependent on oil viscosity, pump speed, swashplate angle, and system pressure.

When the solenoid is energized, charge flow and pressure is allowed to reach the pump controls. The X7 logic port will also be connected to charge pressure and flow.

The charge supply side of the control cut off valve is internally screened to protect the spool from contamination.

The solenoid control is intended to be independent of the primary pump control making the control cut off an override control feature. It is however recommended that the control logic of the CCO valve be maintained such that the primary pump control signal is also disabled whenever the CCO valve is de-energized. Other control logic conditions may also be considered.

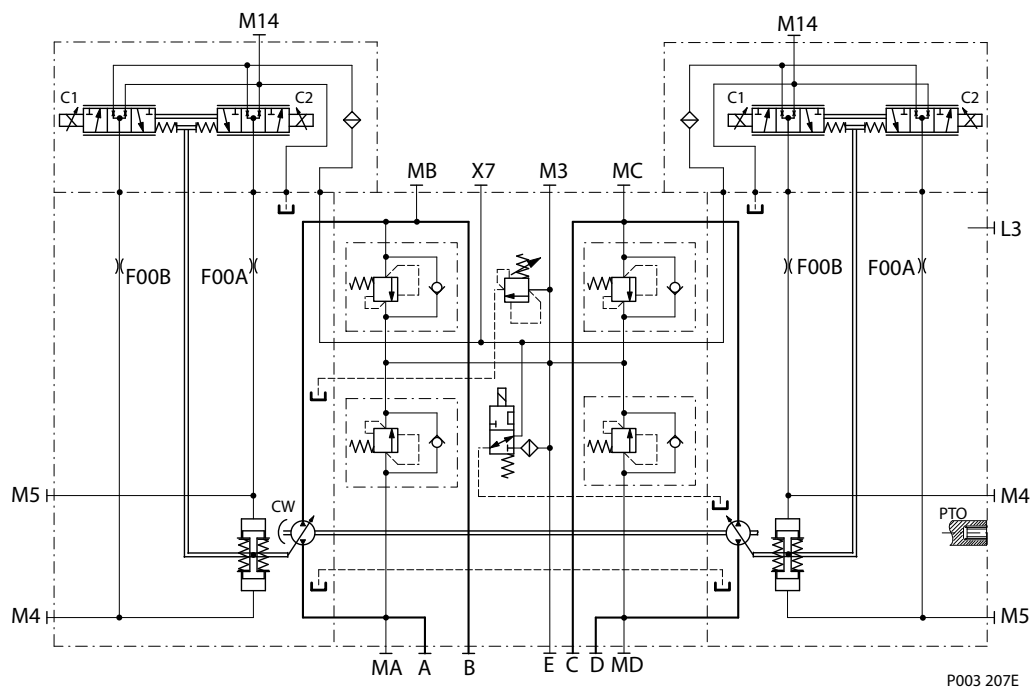
Control options
Pump schematic

Solenoid data

Description		12 V	24 V
Minimum supply voltage		9 V _{DC}	18 V _{DC}
Maximum supply voltage (continuous)		16 V _{DC}	32 V _{DC}
IP Rating	IEC 60 529	IP 67	
	DIN 40 050, part 9	IP 69K with mating connector	
Pin connector		any order	

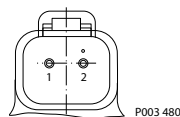
[For additional information, please contact Danfoss.](#)

Connector

Connector ordering data

Description	Quantity	Ordering number
Mating connector	1	Deutsch® DT06-2S
Wedge lock	1	Deutsch® W2S
Socket contact (16 and 18 AWG)	2	Deutsch® 0462-201-16141
Danfoss mating connector kit	1	K29657

Technical Information H1 Axial Piston Tandem Pumps, Size 045/053

Control options
Displacement limiter

H1 pumps are designed with optional mechanical displacement (stroke) limiters factory set to max. displacement. The maximum displacement of the pump can be set independently for forward and reverse using the two adjustment screws to mechanically limit the travel of the servo piston down to 50 % displacement.

Adjustments under operating conditions may cause leakage. The adjustment screw can be completely removed from the threaded bore if backed out to far.

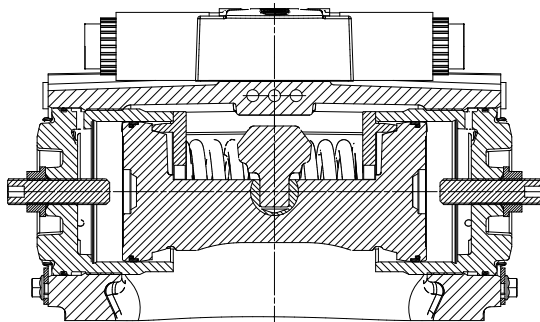

P003 266

Displacement change (approximately) H1P 045/053 Single

Parameter	Size 045	Size 053
1 Turn of displacement limiter screw	5.1 cm ³ [0.31 in ³]	6.0 cm ³ [0.37 in ³]
Internal wrench size	4 mm	
External wrench size	13 mm	
Torque for external hex seal lock nut	23 N·m [204 lbf·in]	

For more information, see *H1 Axial Piston Pumps, Service Manual 520L0848*, the section "Displacement Limiter Adjustment".

Dimensions

Ports description H1P 045/053 Tandem

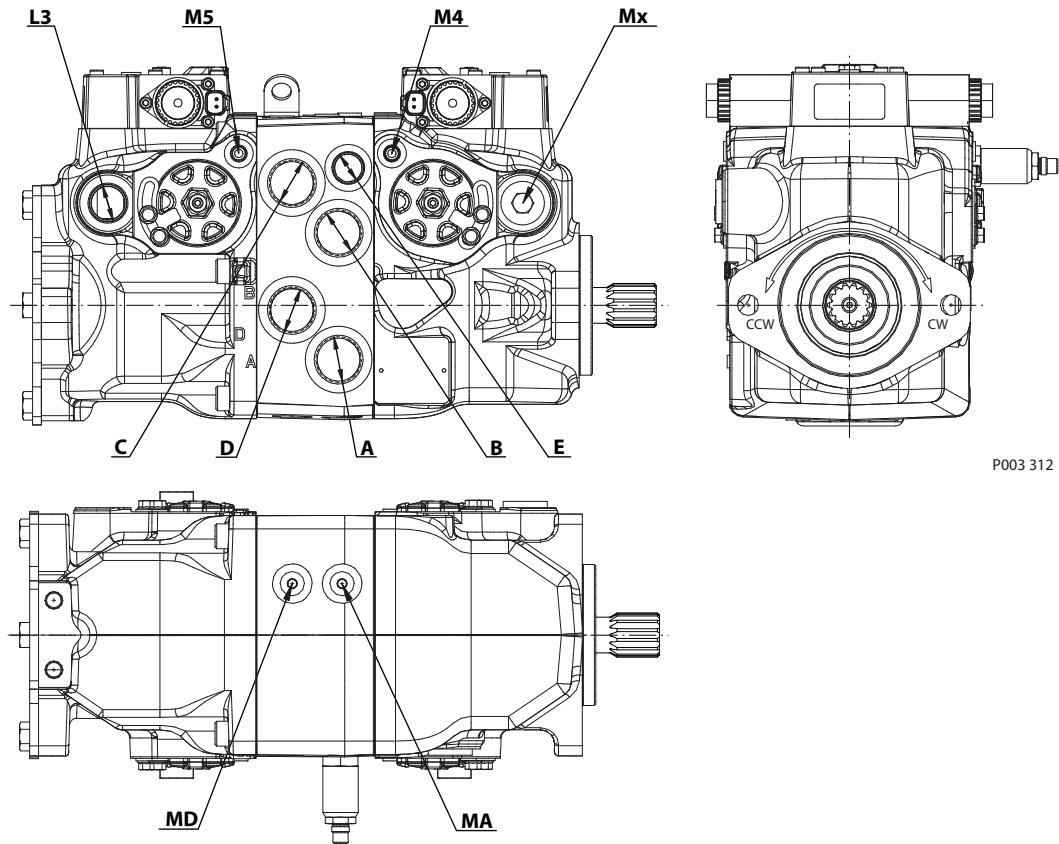

P003 312

Mounting flange, shaft and connector surfaces to be paint free.

Ports description, ISO 11926-1

Ports	Description	Sizes
A, B, C, D	System ports: A, B, C and D; Ø48.5 max. clearance for fitting	1 ⁵ / ₁₆ - 12
MA, MB, MC, MD	System gauge ports A, B, C and D; Ø28 max. clearance for fitting	9 ¹ / ₁₆ - 18
E	Charge filtration inlet port from filter; Ø36 max. clearance for fitting	7 ⁷ / ₈ - 14
L3	Case drain port; Ø48.5 max. clearance for fitting	1 ¹ / ₁₆ - 12
M3 / Mx	Charge gauge / constr. port; Ø28 max. clearance for fitting	9 ¹ / ₁₆ - 18
M4, M5	Servo gauge ports; Ø24.5 max. clearance for fitting	7 ⁷ / ₁₆ - 20
M14	Case gauge port; Ø21 max. clearance for fitting (EDC, MDC, FNR, NFPE)	7 ⁷ / ₁₆ - 20
X7	Brake gauge port	9 ¹ / ₁₆ - 18

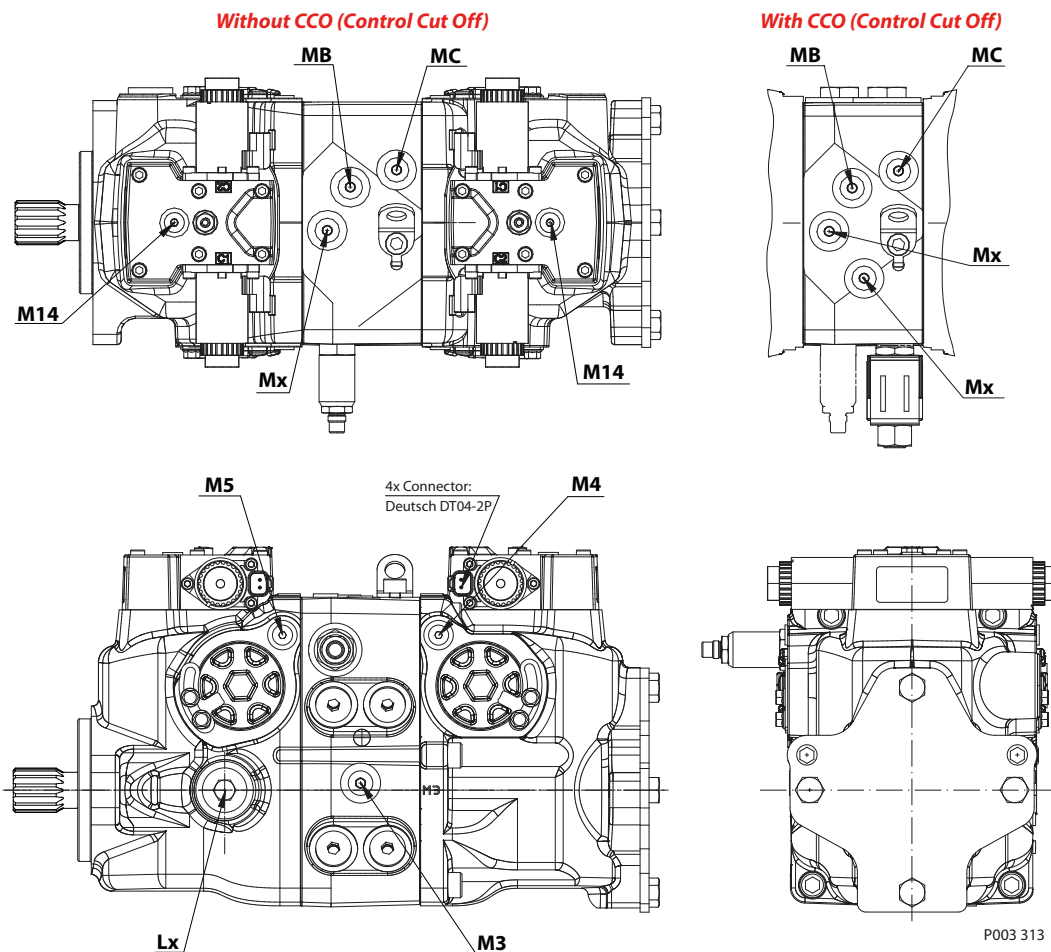
Dimensions

Mounting flange, shaft and connector surfaces to be paint free.

Ports description, ISO 11926-1

Ports	Description	Sizes
A, B, C, D	System ports: A, B, C and D ; Ø48.5 max. clearance for fitting	1 ⁵ / ₁₆ - 12
MA, MB, MC, MD	System gauge ports A, B, C and D ; Ø28 max. clearance for fitting	9/ ₁₆ - 18
E	Charge filtration inlet port from filter; Ø36 max. clearance for fitting	7/ ₈ - 14
Lx	Case pressure port; Ø48.5 max. clearance for fitting	1 ¹ / ₁₆ - 12
M3 / Mx	Charge gauge / constr. port; Ø28 max. clearance for fitting	9/ ₁₆ - 18
M4, M5	Servo gauge ports; Ø24.5 max. clearance for fitting	7/ ₁₆ - 20
M14	Case gauge port; Ø21 max. clearance for fitting (EDC, MDC, FNR, NFPE)	7/ ₁₆ - 20
X7	Brake gauge port	9/ ₁₆ - 18

Please contact Danfoss Power Solutions representative for specific installation drawings.

Dimensions

Dimensions H1T 045/053 Tandem

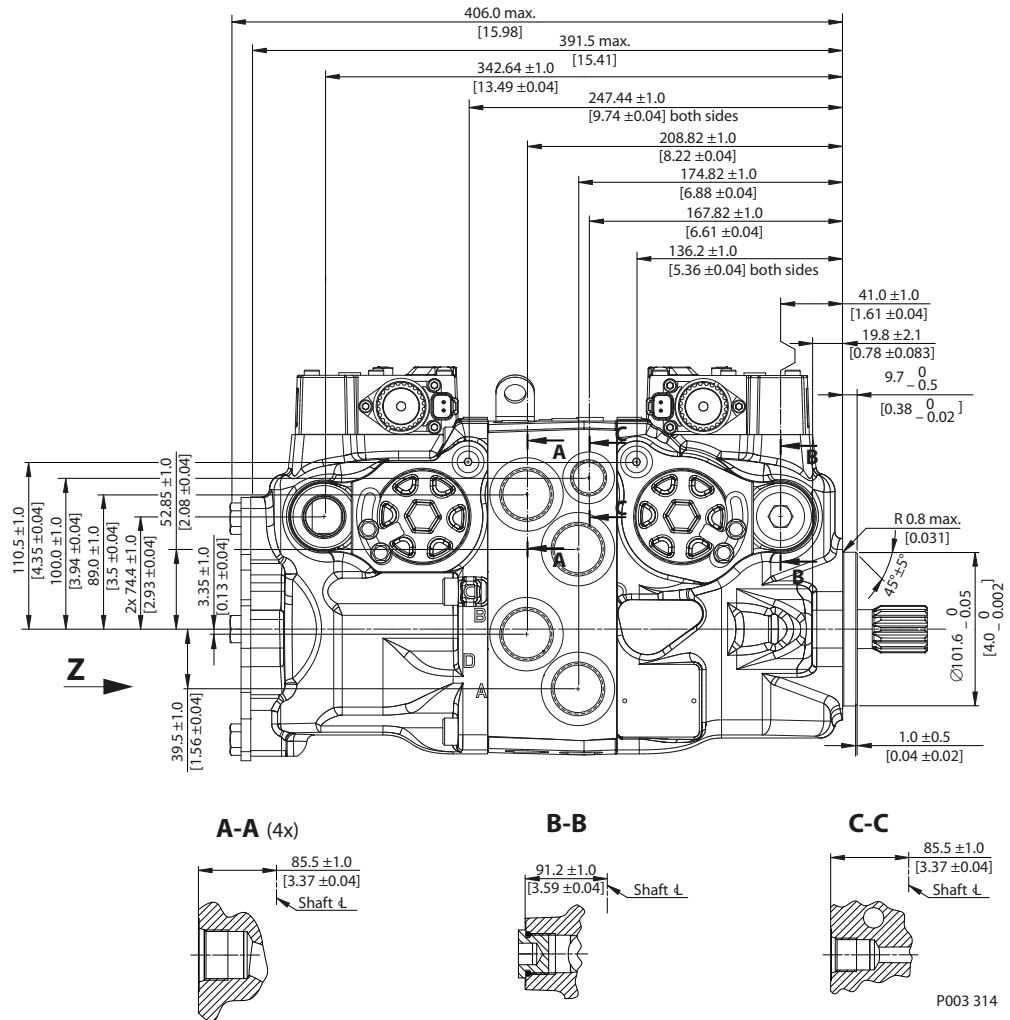

Important

L3 case drain port must be used (see the section [Case drain](#) on page 10 for more details).

Please contact Danfoss Power Solutions representative for specific installation drawings.

Dimensions

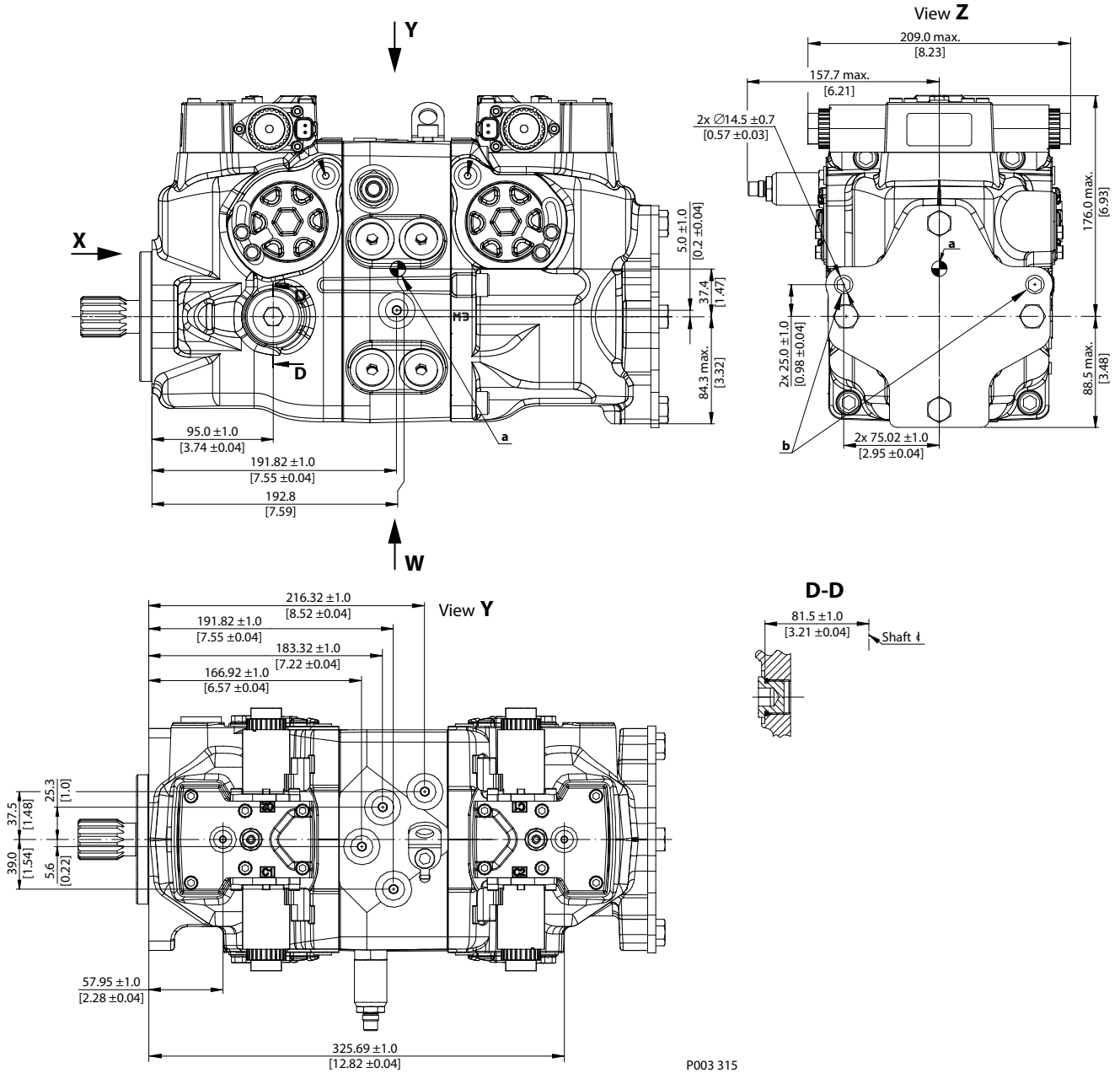

Notes in the drawing:

- a – Approximate center of gravity
- b – Lifting holes weight limit not to exceed 75 kg [165 lb]

Please contact Danfoss Power Solutions representative for specific installation drawings.

Dimensions

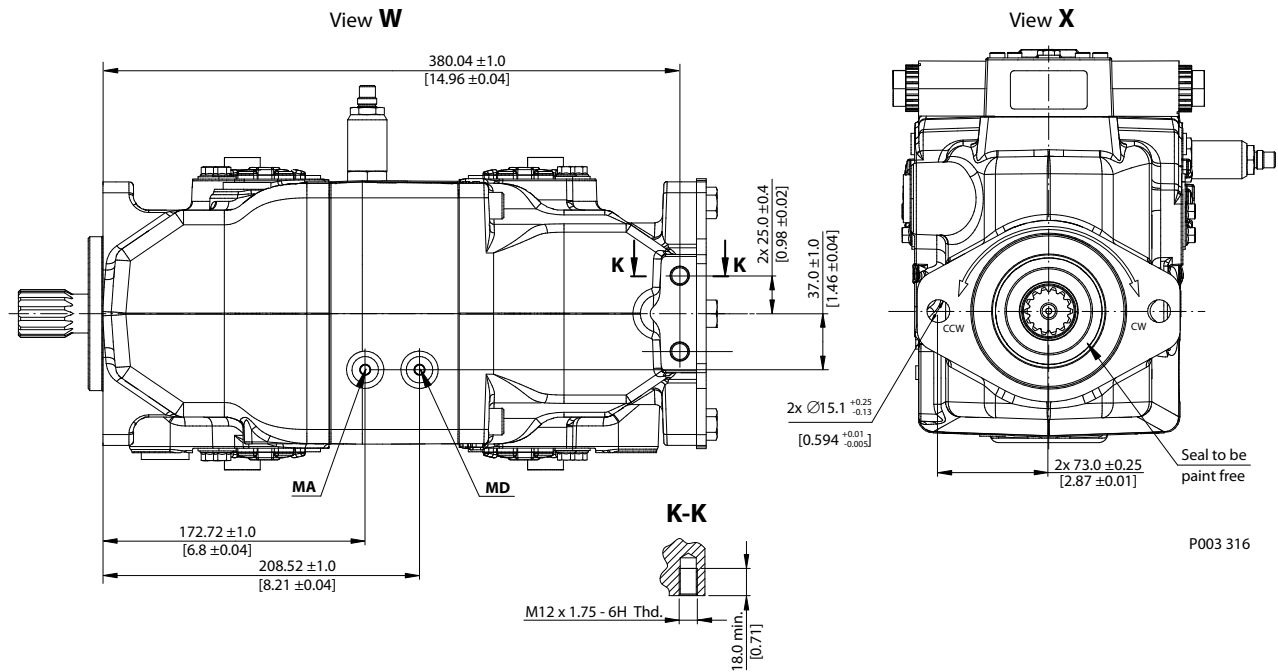

Mounting bolt holes are sized for 14 mm fasteners. M12 or ½ inch can be used, but require a hardened washer.

Please contact Danfoss Power Solutions representative for specific installation drawings.

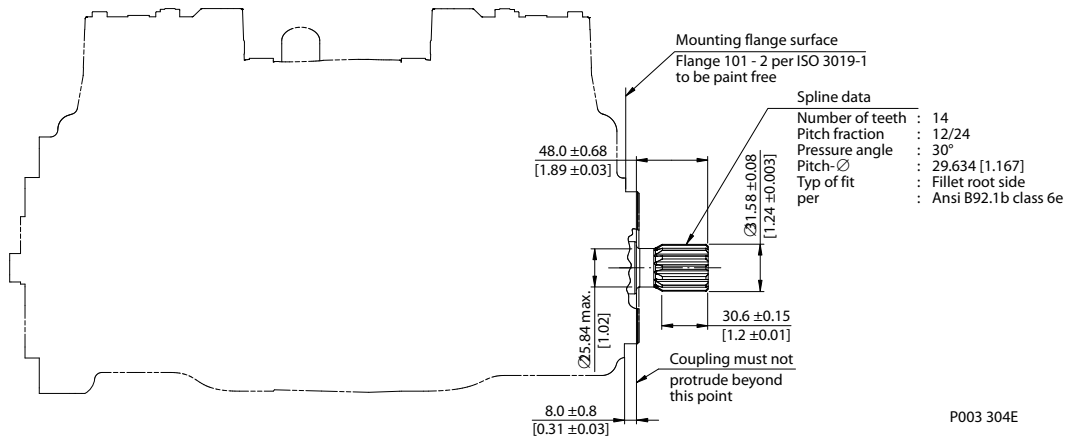
Dimensions
H1T input shaft, option G1 (SAE B, 14 teeth)
Option G1, ISO 3019-1, outer dia 32 mm-4 (SAE B, 14 teeth)

Specifications

Option		G1
Spline		14 teeth, 12/24 pitch
Min. active spline length ¹⁾		30.6 mm [1.205 in]
Torque rating ²⁾	Rated	534 N•m [4720 lbf•in]
	Maximum	592 N•m [5240 lbf•in]

¹⁾ Minimum active spline length for the specified torque ratings.

²⁾ For definitions of maximum and rated torque values, refer to *Basic Information 11062168*, section Shaft Torque Ratings and Spline Lubrication.

Dimensions

H1T input shaft, option G5 (SAE B-B, 15 teeth)

Option G5, ISO 3019-1, outer dia 25 mm-4 (SAE B-B, 15 teeth)

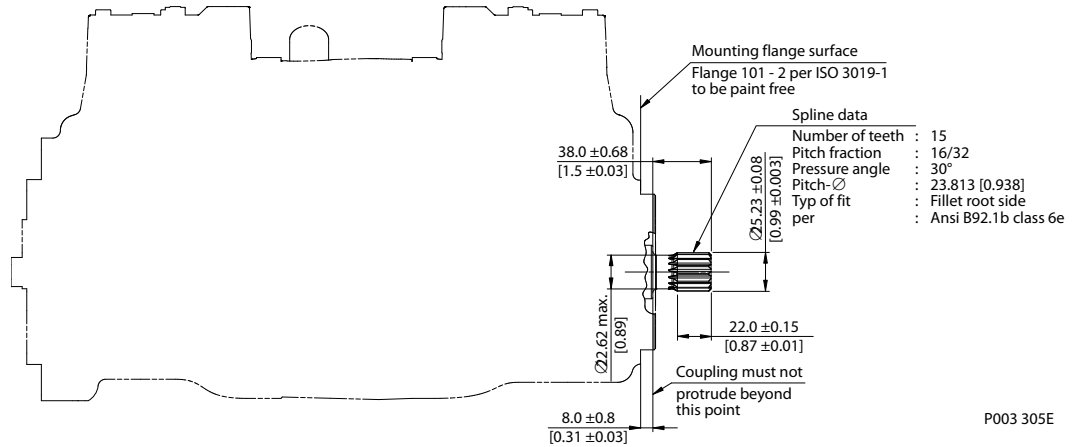

Specifications

Option	G5	
Spline	15 teeth, 16/32 pitch	
Min. active spline length¹⁾	22 mm [0.866 in]	
Torque rating²⁾	Rated	277 N·m [2450 lbf·in]
	Maximum	370 N·m [3270 lbf·in]

¹⁾ Minimum active spline length for the specified torque ratings.

²⁾ For definitions of maximum and rated torque values, refer to *Basic Information 11062168*, section Shaft Torque Ratings and Spline Lubrication.

Dimensions
H1T input shaft, option F2, Code 25-3

Option F2, ISO 3019-1, Code 25-3, Diameter 25.4 taper 1:8, without key and no through-hole in the end of the shaft

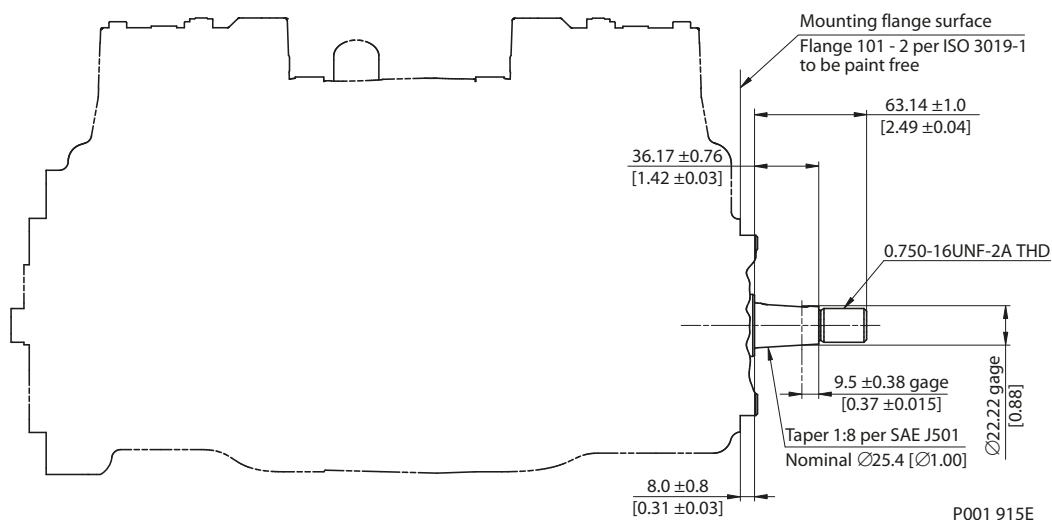
Specifications

Option		F2
Tapered shaft ¹⁾		25.4 taper without key
Torque rating ²⁾	Rated ³⁾	405 N·m [3580 lbf·in]
	Maximum	540 N·m [4780 lbf·in]

¹⁾ Mating part must maintain a minimum gap width of 1.0 mm with the shaft shoulder after installation of the part. Transmittable torque will be reduced if the minimum gap requirement is not met.

²⁾ For definitions of maximum and rated torque values, refer to *Basic Information 11062168*, section Shaft Torque Ratings and Spline Lubrication.

³⁾ Rated torque includes just the capability of the press-fit in accordance with an assumed fastener grade 5.

Tapered shaft customer acknowledgement

The Danfoss H1 tapered shaft has been designed using the industry standard ISO 3019-1, minus the through-hole in the end of the shaft. Danfoss recommends a self-locking nut instead of a castle nut and pin. The nut and mating square-cut key are customer supplied.

The specified torque rating of the tapered shaft documented above is based on the cross-sectional diameter of the shaft, through the keyway, and assumes the proper clamp and fit between shaft and coupling. Danfoss guarantees the design and manufactured quality of the tapered shaft. The customer is responsible for the design and manufactured quality of the mating female coupling and key and applied torque on the nut. Danfoss has made provisions for the key in accordance to the ISO specification with the understanding that the key is solely to assist in the installation of the mating coupling.

Caution

Torque must be transmitted by the taper fit between the shaft and it's mating coupling, not the key. Torque or loading inadvertently transmitted by the customer supplied key may lead to premature shaft failure.

Dimensions

External charge pump mounting options

Setting option S01

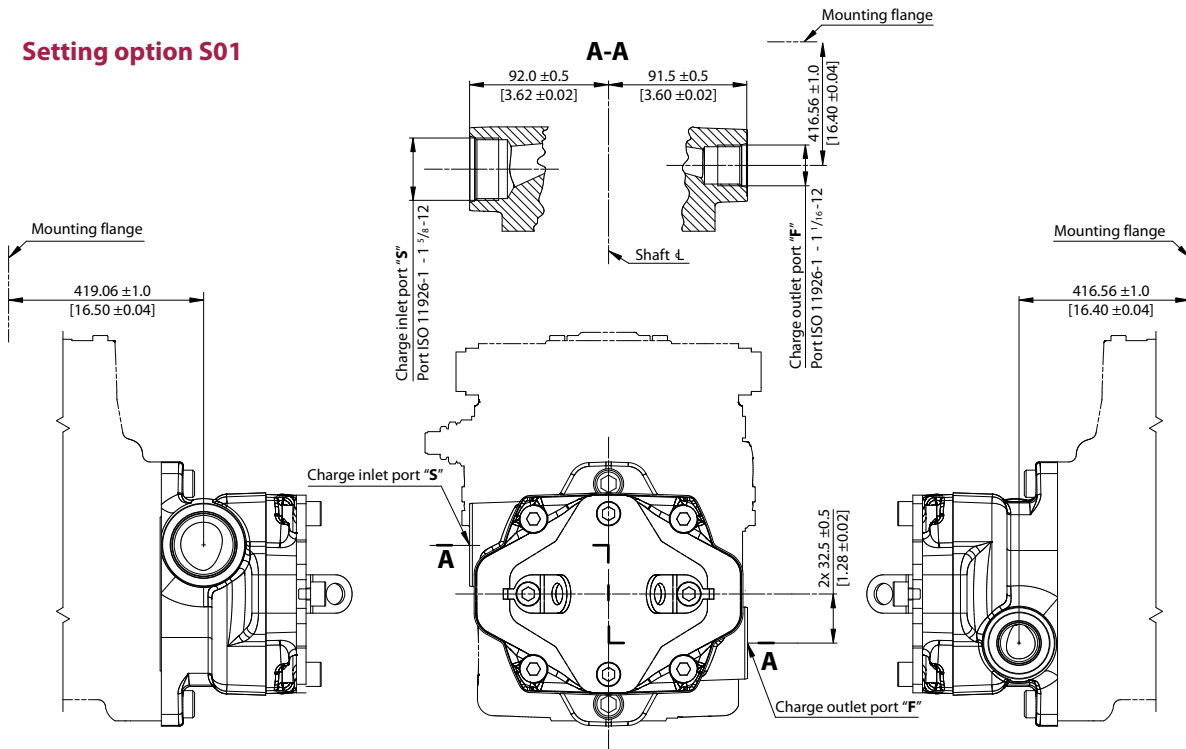

Setting option S02

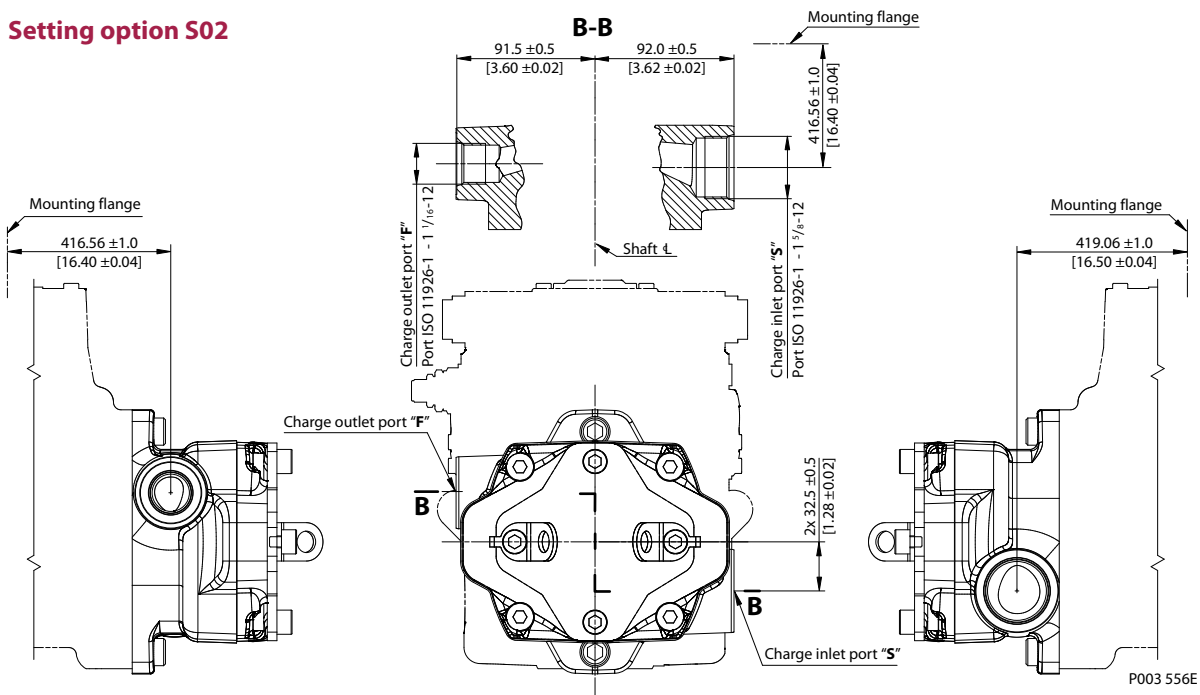

P003 556E

Please contact Danfoss Power Solutions representative for specific installation drawings.

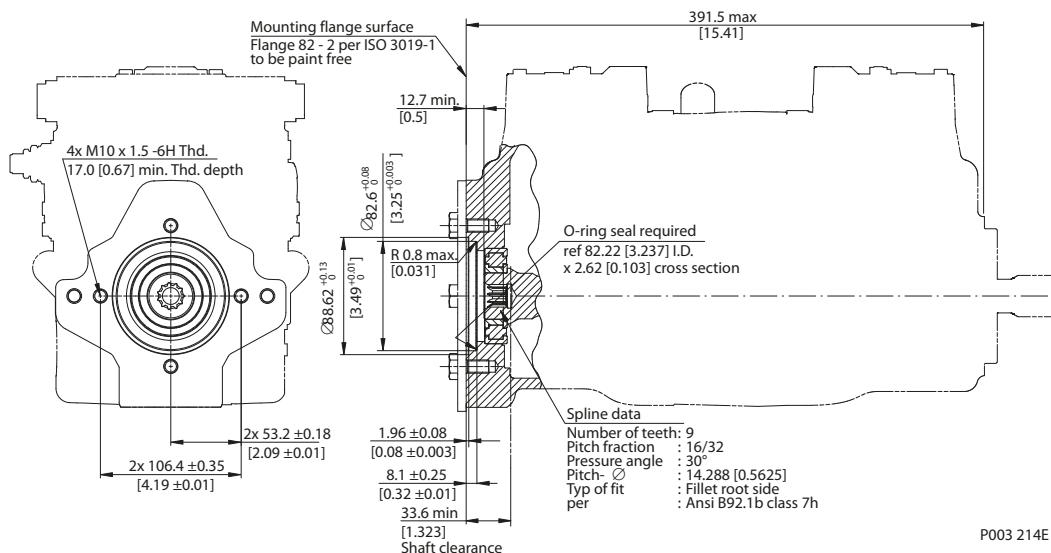
Dimensions
Auxiliary mounting pads without charge pump
H1T Auxiliary mounting, option H2 (SAE A, 9 teeth)
Option H2, ISO 3019-1, flange 82-2 (SAE A, 9 teeth)

Specifications

Option	H2
Spline	9 teeth, 16/32 pitch
Maximum torque ¹⁾	162 N·m [1430 lbf·in]

¹⁾ For definitions of maximum and rated torque values, refer to *Basic Information 11062168*, section Shaft Torque Ratings and Spline Lubrication.

⚠ Caution

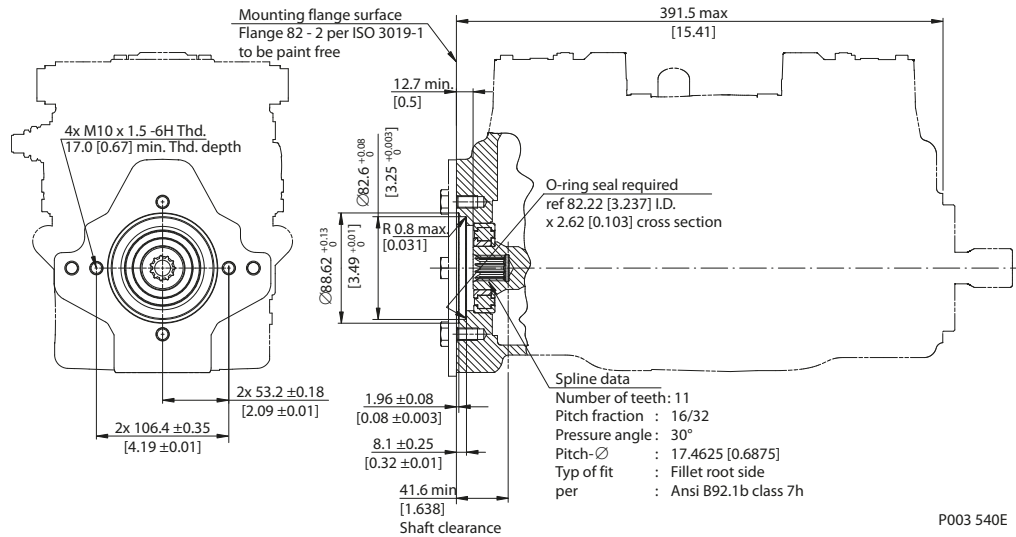
Standard pad cover is installed only to retain coupling during shipping. Do not operate pump without an auxiliary pump or running cover installed.

Dimensions
H1T Auxiliary mounting, option H1 (SAE A, 11 teeth)
Option H1, ISO 3019-1, Flange 82-2 (SAE A, 11 Teeth)

Specifications

Option	H1
Spline	11 teeth, 16/32 pitch
Maximum torque ¹⁾	296 N·m [2620 lbf·in]

¹⁾ For definitions of maximum and rated torque values, refer to *Basic Information 11062168*, section Shaft Torque Ratings and Spline Lubrication.

Caution

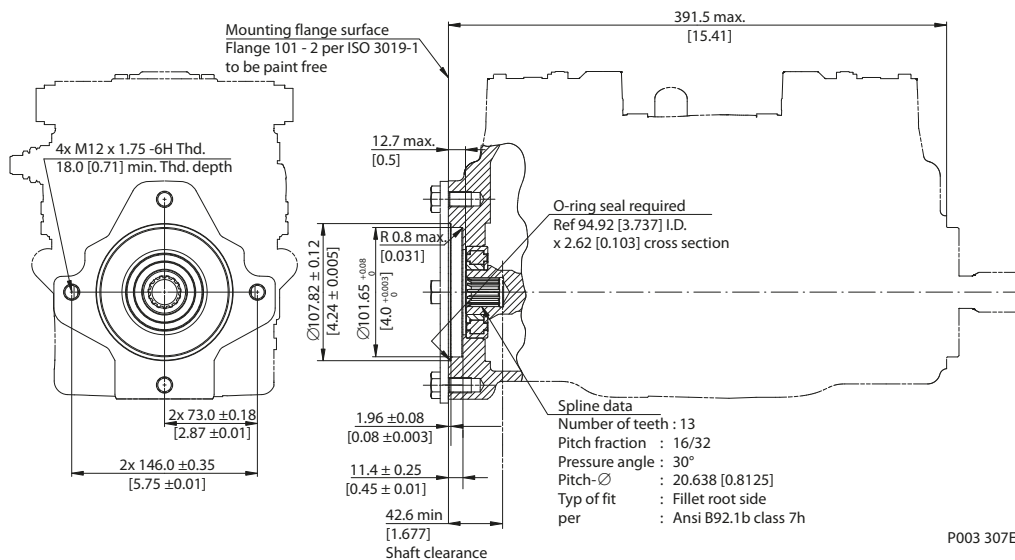
Standard pad cover is installed only to retain coupling during shipping. Do not operate pump without an auxiliary pump or running cover installed.

Dimensions
H1T Auxiliary mounting, option H3 (SAE B, 13 teeth)
Option H3, ISO 3019-1, Flange 101-2 (SAE B, 13 Teeth)

Specifications

Option	H3
Spline	13 teeth, 16/32 pitch
Maximum torque¹⁾	395 N·m [3500 lbf·in]

¹⁾ For definitions of maximum and rated torque values, refer to *Basic Information 11062168*, section Shaft Torque Ratings and Spline Lubrication.

Caution

Standard pad cover is installed only to retain coupling during shipping. Do not operate pump without an auxiliary pump or running cover installed.

Dimensions

H1T Auxiliary mounting, option H5 (SAE B-B, 15 teeth)

Option H5, ISO 3019-1, Flange 101-2 (SAE B-B, 15 Teeth)

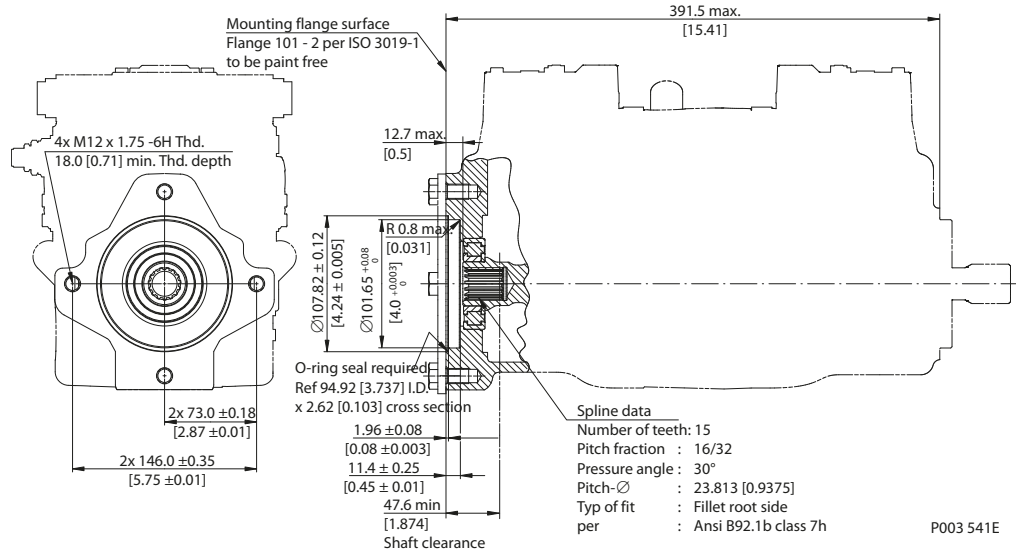

Specifications

Option	H5
Spline	15 teeth, 16/32 pitch
Maximum torque¹⁾	405 N•m [3580 lbf•in]

¹⁾ For definitions of maximum and rated torque values, refer to *Basic Information 11062168*, section Shaft Torque Ratings and Spline Lubrication.

Caution

Standard pad cover is installed only to retain coupling during shipping. Do not operate pump without an auxiliary pump or running cover installed.

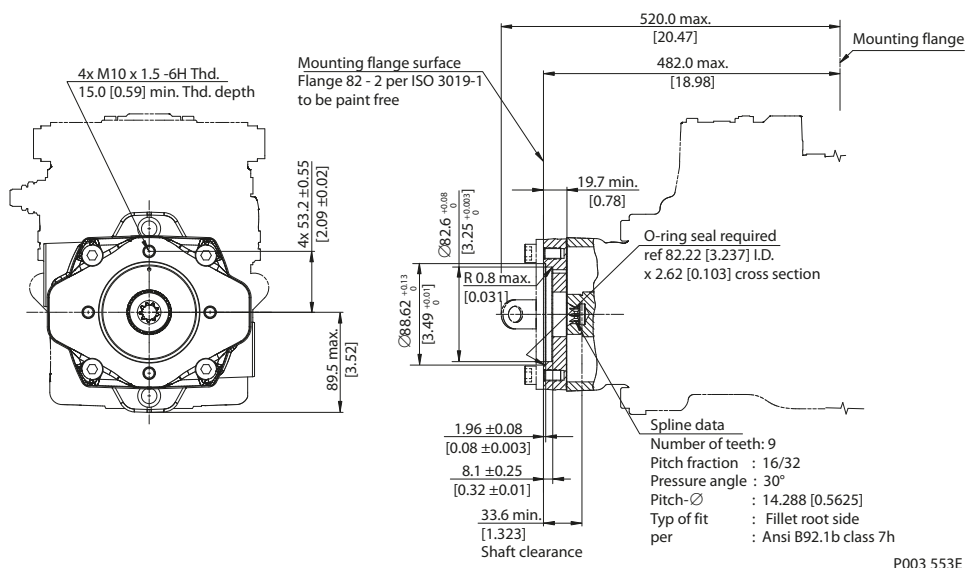
Dimensions
Auxiliary mounting pads with external charge pump
Option T2 (SAE A, 9 teeth)
Option T2, ISO 3019-1, flange 82-2 (SAE A, 9 teeth)

Specifications

Option	T2
Spline	9 teeth, 16/32 pitch
Maximum torque ¹⁾	162 N·m [1430 lbf·in]

¹⁾ For definitions of maximum and rated torque values, refer to *Basic Information 11062168*, section Shaft Torque Ratings and Spline Lubrication.

! Caution

Standard pad cover is installed only to retain coupling during shipping. Do not operate pump without an auxiliary pump or running cover installed.

Dimensions

Option T1 (SAE A, 11 teeth)

Option T1, ISO 3019-1, flange 82-2 (SAE A, 11 teeth)

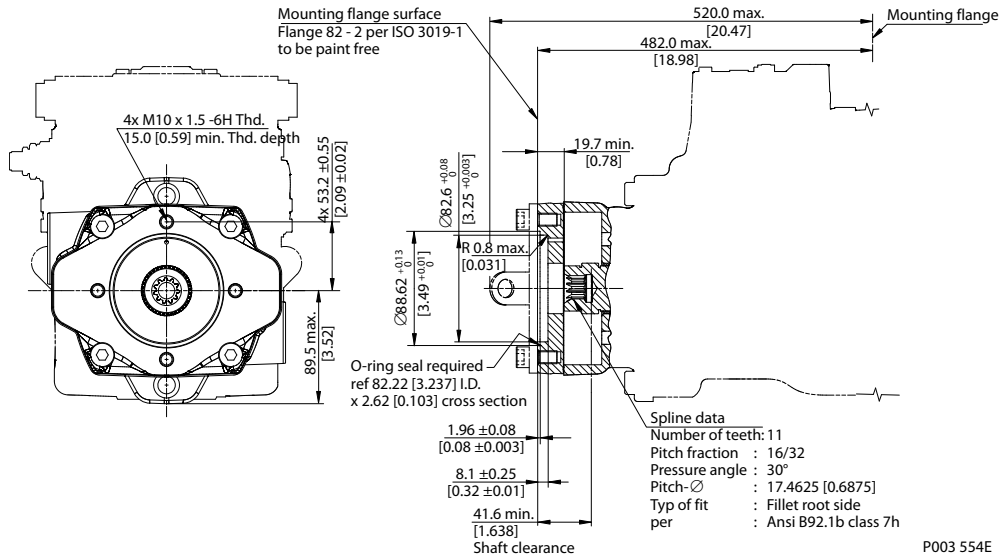

P003 554E

Specifications

Option	T1
Spline	11 teeth, 16/32 pitch
Maximum torque¹⁾	222 N•m [1965 lbf•in]

¹⁾ For definitions of maximum and rated torque values, refer to *Basic Information 11062168*, section Shaft Torque Ratings and Spline Lubrication.

! Caution

Standard pad cover is installed only to retain coupling during shipping. Do not operate pump without an auxiliary pump or running cover installed.

Dimensions

Option T3 (SAE B, 13 teeth)

Option T3, ISO 3019-1, flange 101-2 (SAE B, 13 teeth)

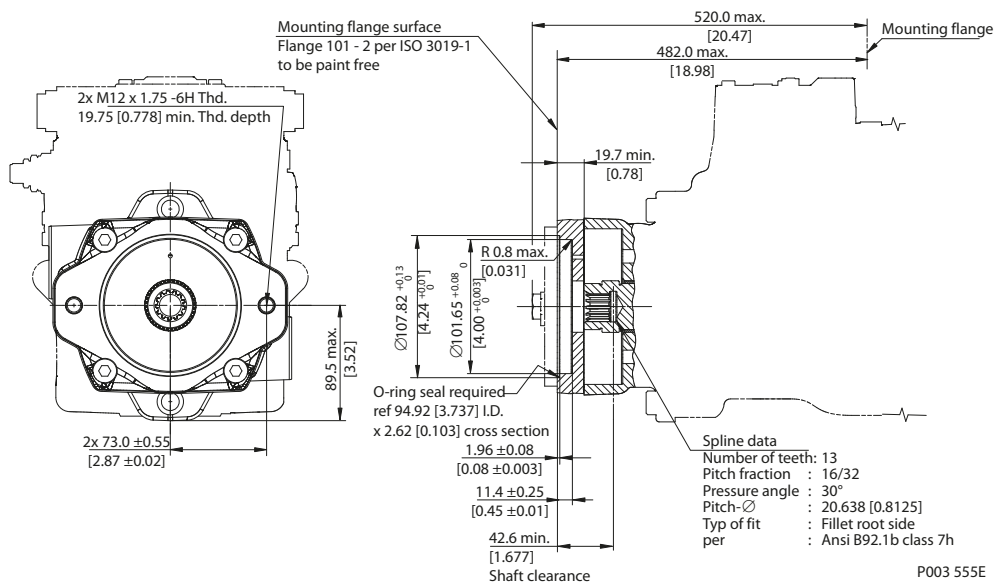

Excessive bolt length could cause leak or damage to the unit.

Specifications

Option	T3
Spline	13 teeth, 16/32 pitch
Maximum torque¹⁾	222 N·m [1965 lbf·in]

¹⁾ For definitions of maximum and rated torque values, refer to *Basic Information 11062168*, section Shaft Torque Ratings and Spline Lubrication.

⚠ Caution

Standard pad cover is installed only to retain coupling during shipping. Do not operate pump without an auxiliary pump or running cover installed.

Dimensions

Electric Displacement Control (EDC), option A2 (12V) / A3 (24V) H1T 045/053

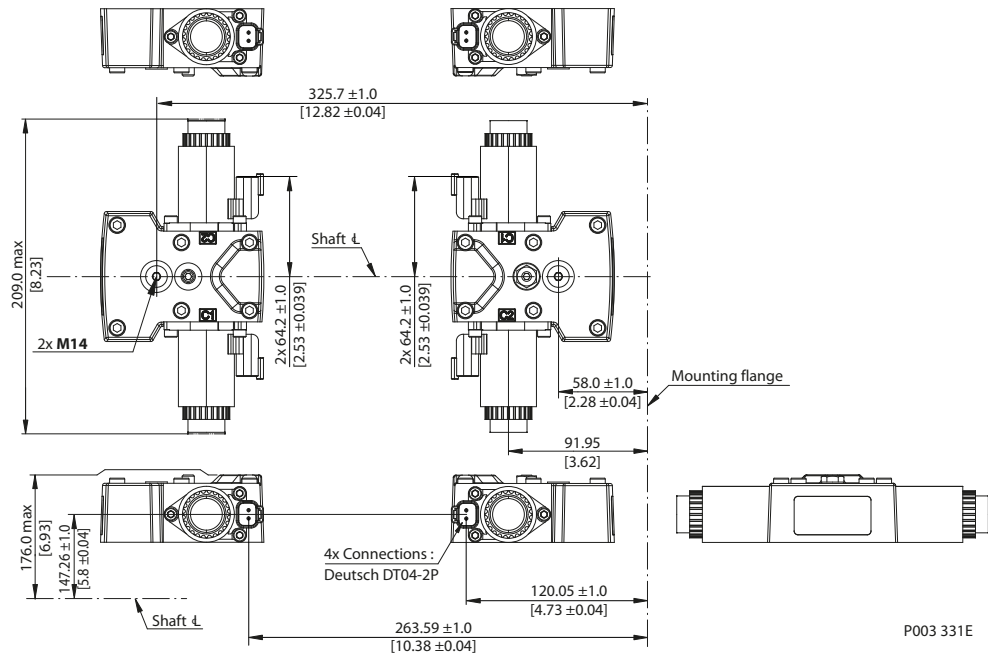

2x Case gauge port **M14**: ISO 11926-1 – 7/16 -20; Ø21.0 max clearance dia for fitting

4x Connectors Deutsch DT04-2P to be paint free

[Please contact Danfoss Power Solutions representative for specific installation drawings.](#)

Electric Displacement Control (EDC) with MOR, option A4 (12 V) / A5 (24 V) H1T 045/053

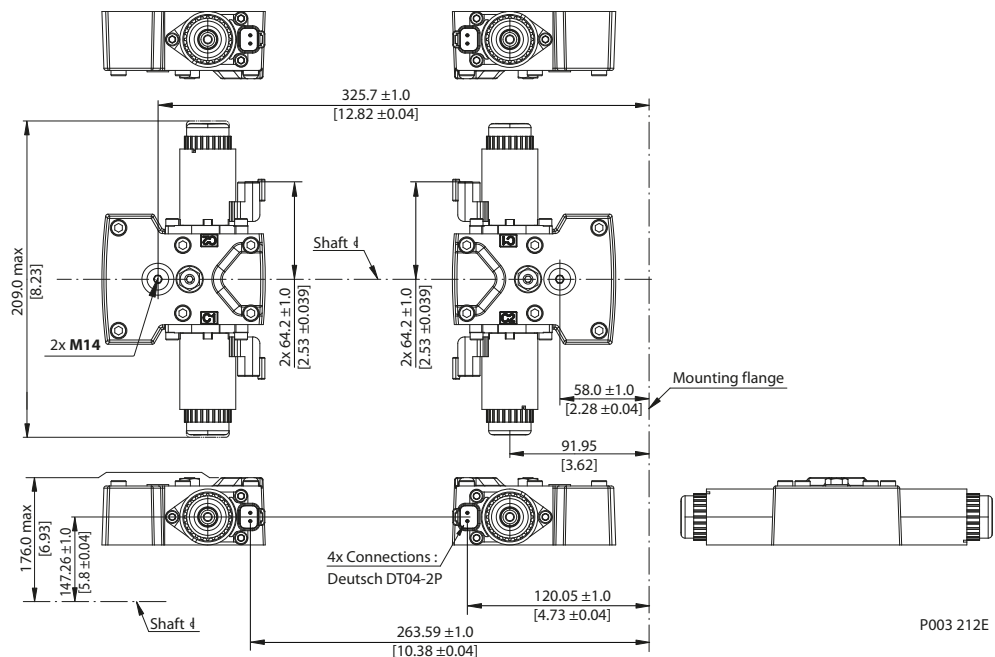

2x Case gauge port **M14**: ISO 11926-1 – 7/16 -20; Ø21.0 max clearance dia for fitting

4x Connectors Deutsch DT04-2P to be paint free

[Please contact Danfoss Power Solutions representative for specific installation drawings.](#)

Technical Information H1 Axial Piston Tandem Pumps, Size 045/053

Dimensions

Manual Displacement Control (MDC), option M1, H1T 045/053

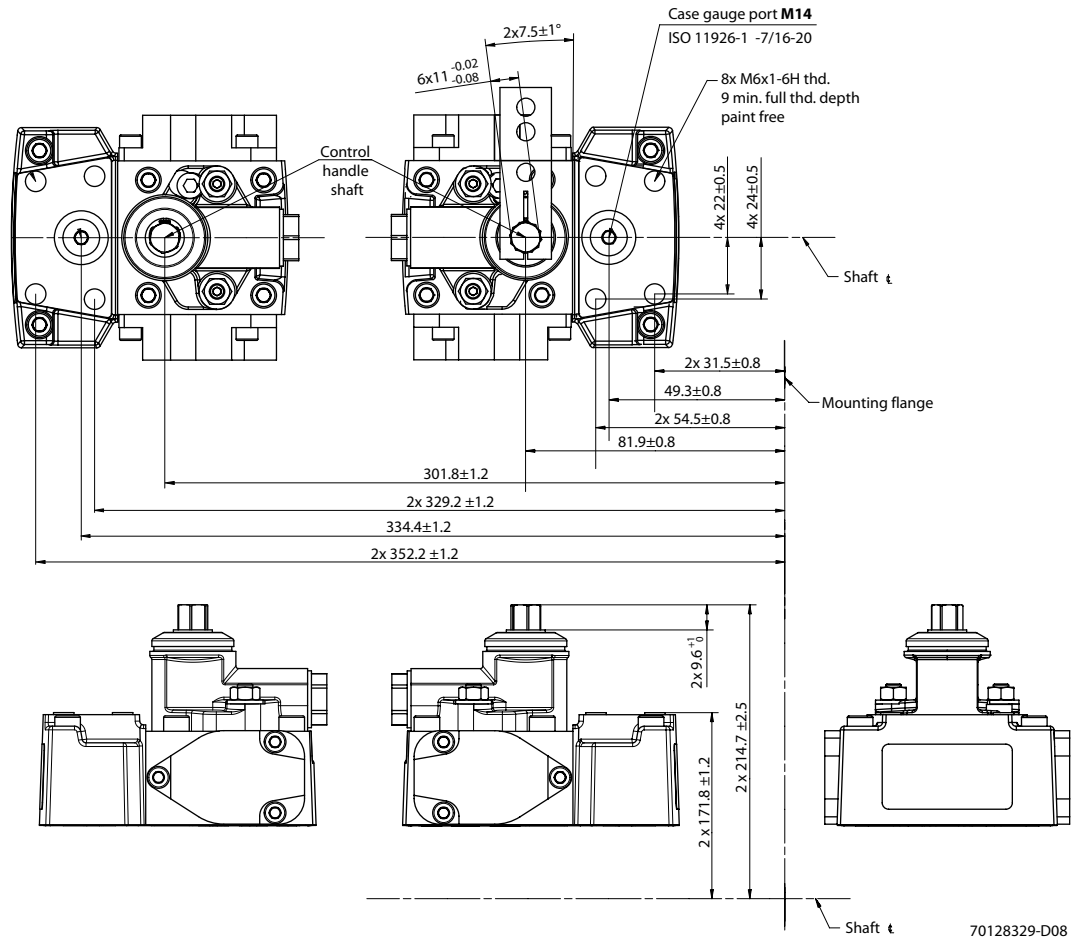

Please contact Danfoss Power Solutions representative for specific installation drawings.

Dimensions

Manual Displacement Control (MDC) with NSS, option M2, H1T 045/053

H1 Tandem 045/053 Manual Displacement Control (MDC) with NSS, option M2

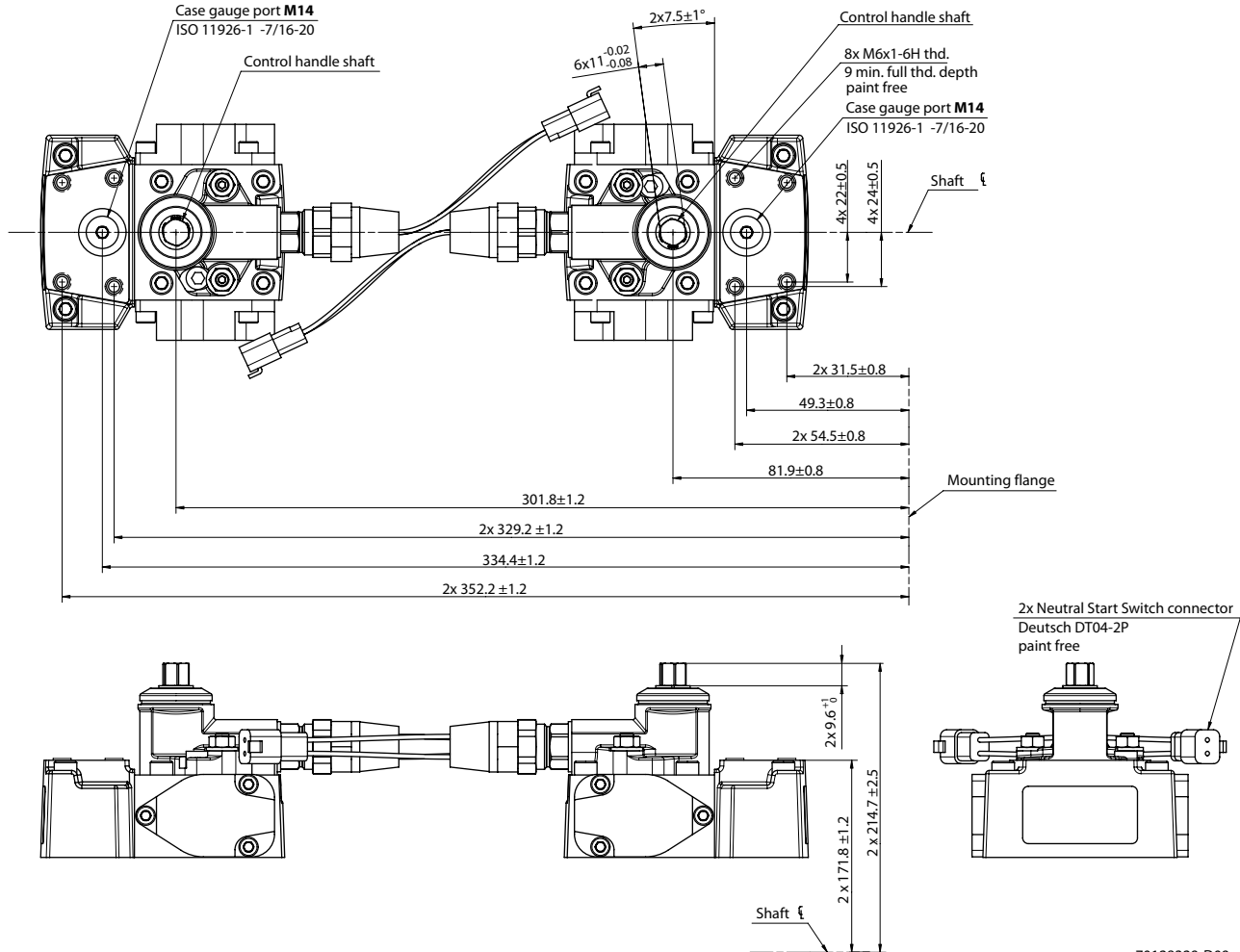

70128329-D09

Neutral Start Switch connector:

Pin	Assignment	OR	Pin	Assignment
1	Supply		1	Ground
2	Ground		2	Supply

Please contact Danfoss Power Solutions representative for specific installation drawings.

Dimensions

Manual Displacement Control (MDC) with NSS, option 09, H1T 045/053

H1 Tandem 045/053 Manual Displacement Control (MDC) with NSS, option 09

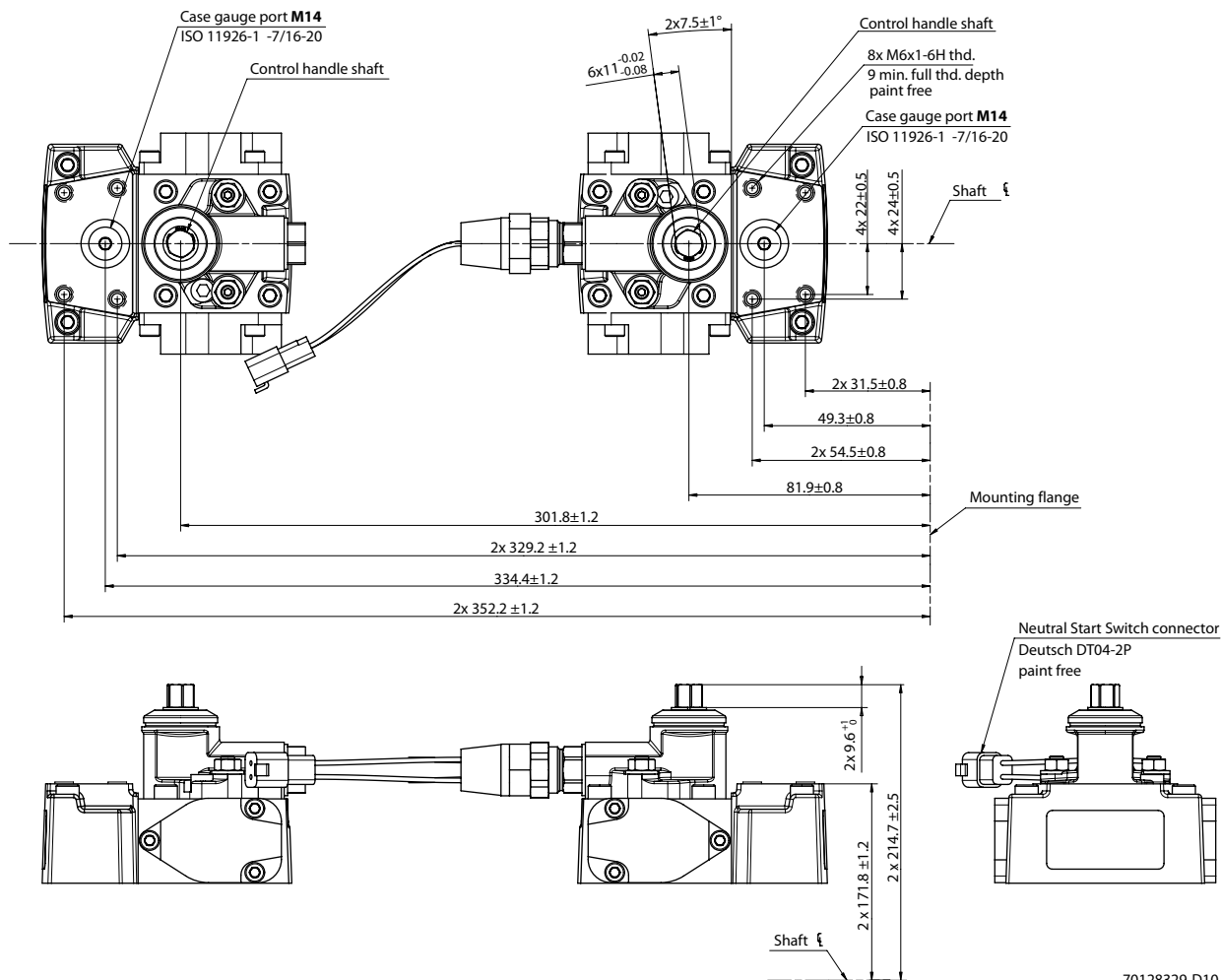

70128329-D10

Neutral Start Switch connector:

Pin	Assignment		Pin	Assignment
1	Supply	OR	1	Ground
2	Ground		2	Supply

Please contact Danfoss Power Solutions representative for specific installation drawings.

Dimensions

Forward-Neutral-Reverse (FNR) with MOR, option A9 (12 V) / B1 (24 V) H1T 045/053

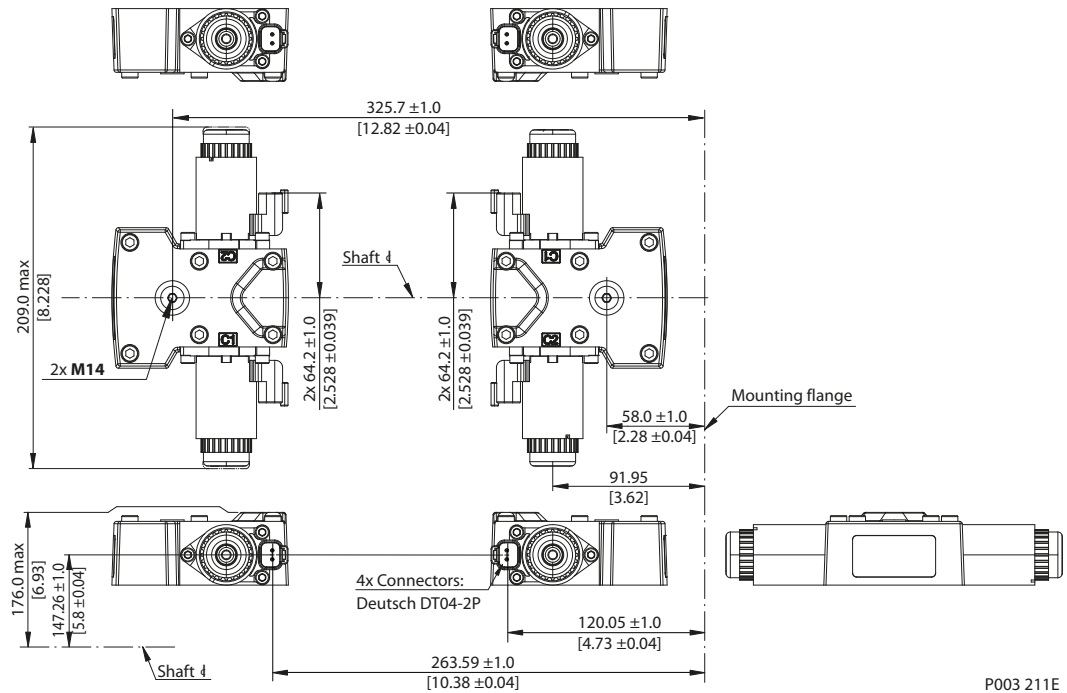

P003 211E

2x Case gauge port **M14**: ISO 11926-1; $\frac{7}{16}$ -20; $\varnothing 21.0$ max clearance dia for fitting.
 4x Connectors Deutsch DT04-2P to be paint free.

Please contact Danfoss Power Solutions representative for specific installation drawings.

Dimensions

Non Feedback Proportional Electric Control (NFPE) with MOR, option A8 (12 V) B8 (24V) H1T 045/053

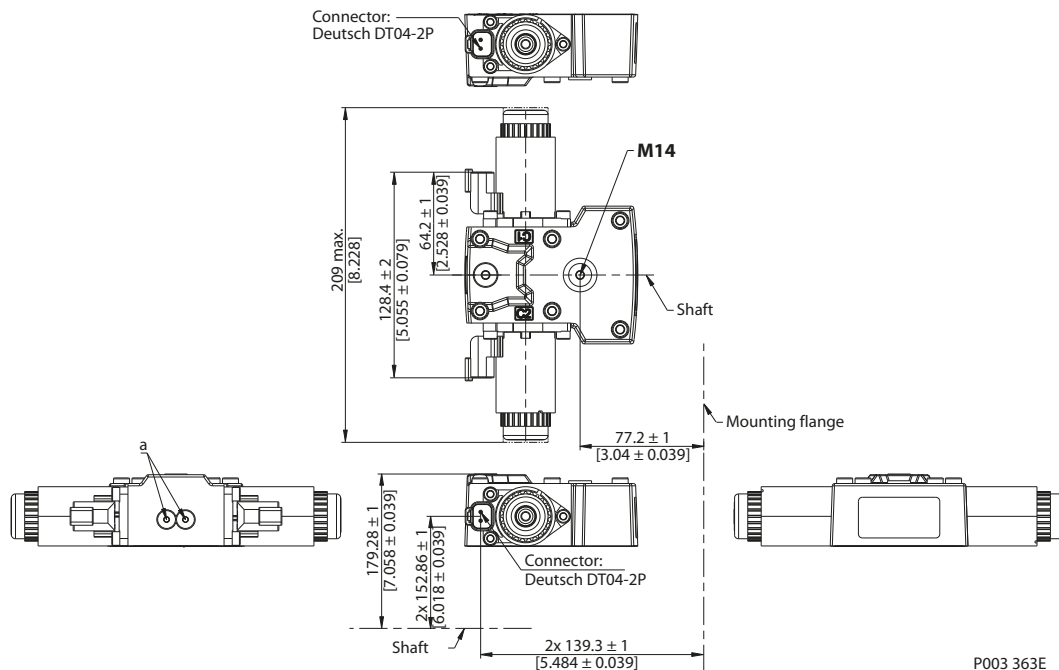

P003 363E

a – plug removing can cause contamination issues.
 Case gauge port **M14**: ISO 11926-1; $7/16-20$; $\varnothing 21.0$ max clearance dia for fitting.
 Connectors Deutsch DT04-2P to be paint free.

Please contact Danfoss Power Solutions representative for specific installation drawings.

Center section coupling, torque rating

Torque rating for center section coupling

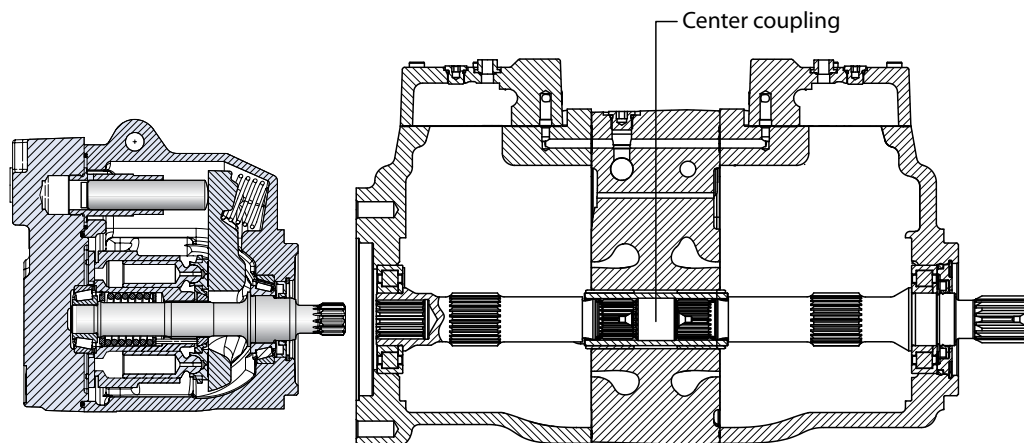

P003 203E

Maximum torque for center coupling: **405 N·m [3580 lbf·in]**

For definitions of maximum and rated torque values, refer to *Basic Information 11062168*, section *Shaft Torque Ratings and Spline Lubrication*.

Dimensions

Control Cut Off (CCO) H1T 045/053

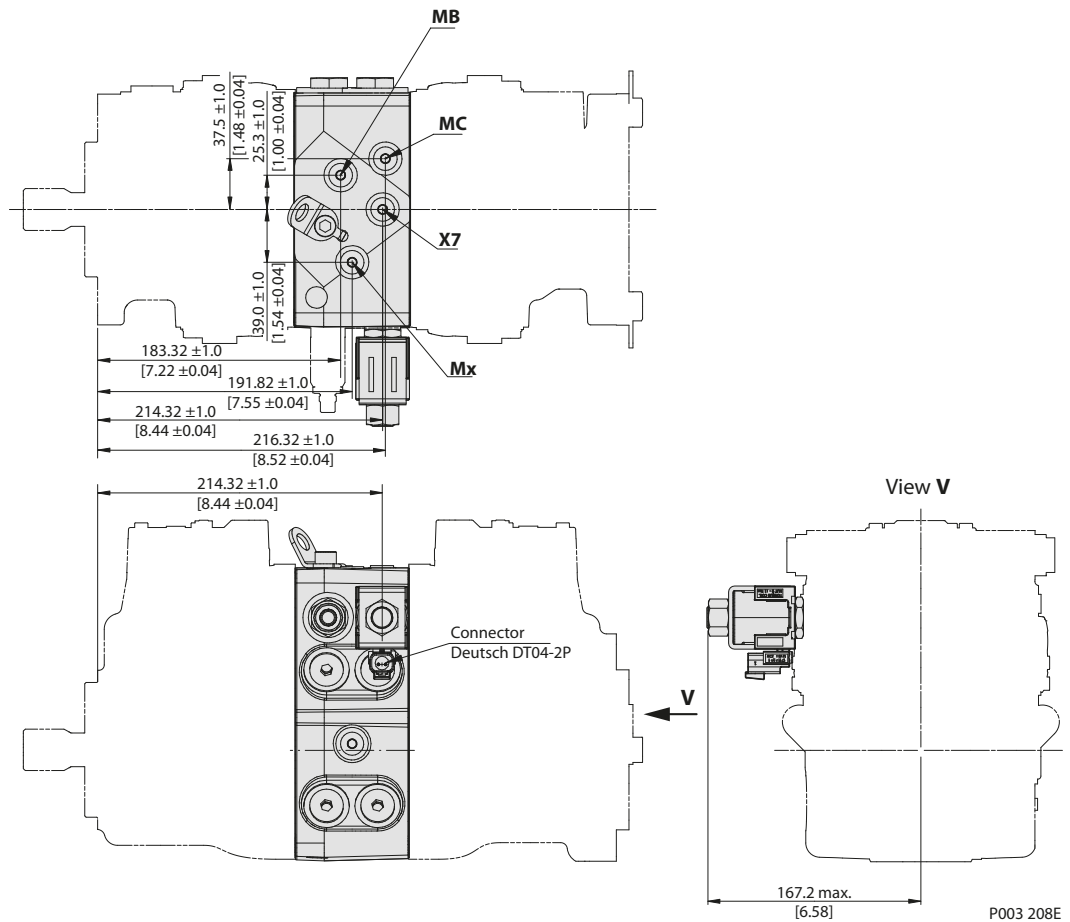

Mounting flange, shaft and connector surfaces to be paint free.

Ports description, ISO 11926-1

Ports	Description	Size
MB, MC	System gauge ports B, C ; Ø28 max. clearance for fitting	9/16 - 18
Mx	Charge constr. port; Ø28 max. clearance for fitting	9/16 - 18
X7	Brake gauge port	9/16 - 18

Please contact Danfoss Power Solutions representative for specific installation drawings.

Technical Information H1 Axial Piston Tandem Pumps, Size 045/053

Dimensions

H1T displacement limiter, 045/053 Tandem, option B

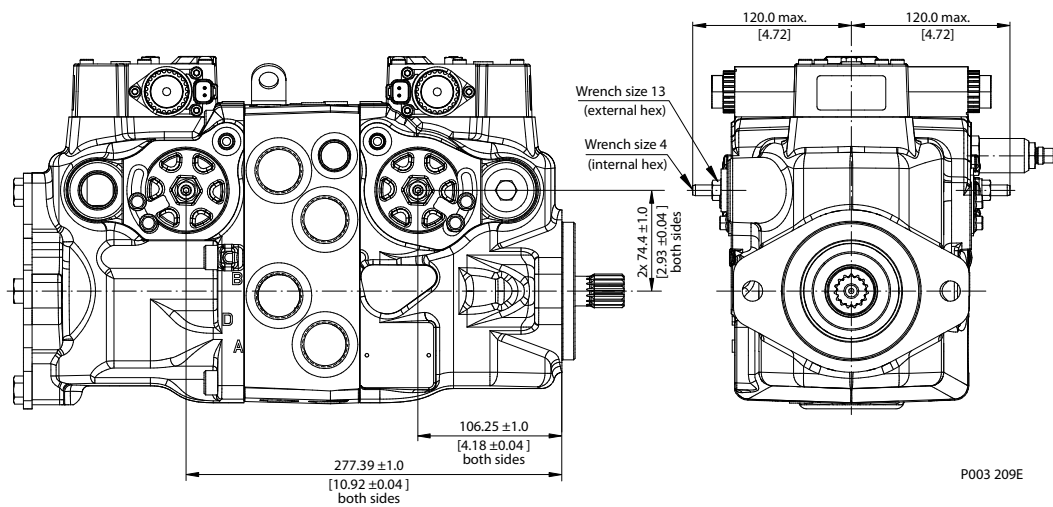

Please contact Danfoss Power Solutions representative for specific installation drawings.



Products we offer:

- Bent Axis Motors
- Closed Circuit Axial Piston Pumps and Motors
- Displays
- Electrohydraulic Power Steering
- Electrohydraulics
- Hydraulic Power Steering
- Integrated Systems
- Joysticks and Control Handles
- Microcontrollers and Software
- Open Circuit Axial Piston Pumps
- Orbital Motors
- PLUS+1® GUIDE
- Proportional Valves
- Sensors
- Steering
- Transit Mixer Drives

Danfoss Power Solutions is a global manufacturer and supplier of high-quality hydraulic and electronic components. We specialize in providing state-of-the-art technology and solutions that excel in the harsh operating conditions of the mobile off-highway market. Building on our extensive applications expertise, we work closely with our customers to ensure exceptional performance for a broad range of off-highway vehicles.

We help OEMs around the world speed up system development, reduce costs and bring vehicles to market faster.

Danfoss – Your Strongest Partner in Mobile Hydraulics.

Go to www.powersolutions.danfoss.com for further product information.

Wherever off-highway vehicles are at work, so is Danfoss. We offer expert worldwide support for our customers, ensuring the best possible solutions for outstanding performance. And with an extensive network of Global Service Partners, we also provide comprehensive global service for all of our components.

Please contact the Danfoss Power Solution representative nearest you.

Comatrol

www.comatrol.com

Schwarzmueller-Inverter

www.schwarzmueller-inverter.com

Turolla

www.turollaocg.com

Hydro-Gear

www.hydro-gear.com

Daikin-Sauer-Danfoss

www.daikin-sauer-danfoss.com

Local address:

Danfoss Power Solutions (US) Company
2800 East 13th Street
Ames, IA 50010, USA
Phone: +1 515 239 6000

Danfoss Power Solutions GmbH & Co. OHG
Krokamp 35
D-24539 Neumünster, Germany
Phone: +49 4321 871 0

Danfoss Power Solutions ApS
Nordborgvej 81
DK-6430 Nordborg, Denmark
Phone: +45 7488 2222

Danfoss Power Solutions Trading (Shanghai) Co., Ltd.
Building #22, No. 1000 Jin Hai Rd
Jin Qiao, Pudong New District
Shanghai, China 201206
Phone: +86 21 3418 5200

Danfoss can accept no responsibility for possible errors in catalogues, brochures and other printed material. Danfoss reserves the right to alter its products without notice. This also applies to products already on order provided that such alterations can be made without changes being necessary in specifications already agreed. All trademarks in this material are property of the respective companies. Danfoss and the Danfoss logotype are trademarks of Danfoss A/S. All rights reserved.