

ENGINEERING  
TOMORROW



Service Manual

# Open Circuit Axial Piston Pumps

## Series 45 F Frame

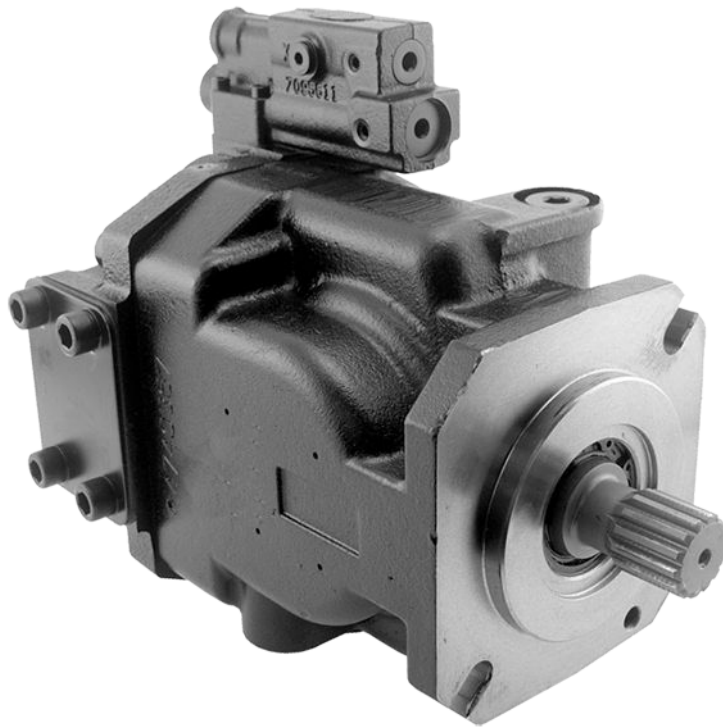

**Revision history***Table of revisions*

<b>Date</b>	<b>Changed</b>	<b>Rev</b>
June 2016	Fix references to TI Manual	0205
June 2016	edits to Fan Drive Control	0204
March 2016	add Fan Drive Control	0203
September 2014	add ETL and angle sensor	BB
August 2014	Danfoss layout	BA
October 2012	add electric controls	AF
November 2010	new back page	AE
February 2010	Fix Osaka address	AD
July 2009	Add Pressure change - PC adjustment specs	AC
September 2007	minor edits and corrections	AB
November 2006	First edition	AA

**Contents**

**Introduction**

Overview.....5  
 Safety precautions.....5  
 Warranty.....6  
 Symbols used in Danfoss literature.....6  
 General description.....6  
 System circuit.....7

**Technical specifications**

General specifications.....9  
     Type of mounting.....9  
     Auxiliary mounting pad options.....9  
     Control options.....9  
     Port options.....9  
     Direction of rotation.....9  
     Installation position.....9  
     Technical specifications.....9  
 Hydraulic parameters.....10  
     Inlet pressure.....10  
     Pressure compensator valve setting.....10  
     Case pressure.....10  
     Hydraulic fluid .....11  
     Temperature range.....11  
     Fluid viscosity.....11  
     Filtration .....11

**Features**

Displacement limiter.....12  
 Auxiliary mounting pads.....12  
 Input shafts.....12  
 Control options.....12  
     General.....12  
     PC control.....13  
     LS control.....13  
     Electric Proportional Controls.....14  
     Electric Proportional Control Principle.....15  
     Electric On/Off Controls.....15  
     Electric On-Off Control Principle.....16  
     Fan Drive Control (FDC).....16  
         PLUS+1 Compliance.....16  
         Fan Drive Control Principle .....17  
         S45 pump with integrated FDC control schematic.....17  
     Electronic Torque Limiting Controls (ETL).....17

**Pressure measurement**

Required tools.....20  
 Port locations and gauge installation.....20

**Initial Start-Up Procedures**

General.....21  
 Start-up procedure.....21

**Fluid and Filter Maintenance**

Recommendations.....22

**Troubleshooting**

Excessive noise and/or vibration.....23  
 Actuator response is sluggish.....23  
 System operating hot.....23  
 Low pump output flow.....24  
 Pressure or flow instability.....24  
 System pressure not reaching PC setting.....25

**Contents**

High inlet vacuum.....	25
------------------------	----

**Adjustments**

PC control.....	26
FDC Control.....	27
Control Adjustment - F Frame.....	28
FDC Control Data.....	29
Fan Drive Control pressure setting guidelines.....	29
LS control.....	29

**Minor repair**

Shaft seal replacement.....	31
Removal.....	31
Installation.....	31
Auxiliary pads.....	31
Removal.....	31
Installation.....	32
LS and PC Controls.....	32
Disassembly.....	32
Inspection.....	33
Reassembly.....	34
Electric Controls.....	35
Disassembly.....	35
Inspection.....	35
Reassembly.....	36
Electronic Torque Limiting Control.....	36
Repair.....	36
Fan Drive Control.....	37
Angle Sensor.....	39
Removal.....	39
Inspection.....	40
Installation.....	40
Servo Control Orifice.....	40
Disassembly.....	40
Reassembly.....	41
Plug and fitting sizes and torques.....	41

## Introduction

### Overview

This manual includes information for the installation, maintenance, and minor repair of the Series 45 Frame F open circuit axial piston pumps. The manual includes a description of the units and their individual components, troubleshooting information, and minor repair procedures. Performing installation, maintenance, and minor repair of Series 45 Frame F axial piston pumps according to the procedures in this manual will not affect your warranty.

Performing minor repairs requires the unit to be removed from the vehicle/machine. Thoroughly clean the unit before beginning maintenance, or repair activities. Since dirt and contamination are the greatest enemies of any type of hydraulic equipment, follow cleanliness requirements strictly. This is especially important when changing the system filter and when removing hoses or plumbing.

A worldwide Global Service Partner Network is available for major repairs. Major repairs require the removal of the unit's endcap, which voids the warranty unless done by a Global Service Partner. Danfoss Global Service Partners are trained by the factory and certified on a regular basis. You can locate your nearest Global Service Partner using the distributor locator at [www.powersolutions.danfoss.com](http://www.powersolutions.danfoss.com)

### Safety precautions

Always consider safety precautions before beginning a service procedure. Protect yourself and others from injury. Take these general precautions whenever servicing a hydraulic system.

#### Unintended machine movement

 **Warning**

---

Unintended movement of the machine or mechanism may cause injury to the technician or bystanders. To protect against unintended movement, secure the machine or disable/disconnect the mechanism while servicing.

---

#### Flammable cleaning solvents

 **Warning**

---

Some cleaning solvents are flammable. To avoid possible fire, do not use cleaning solvents in an area where a source of ignition may be present.

---

#### Fluid under pressure

 **Warning**

---

Escaping hydraulic fluid under pressure can have sufficient force to penetrate your skin causing serious injury and/or infection. This fluid may also be hot enough to cause burns. Use caution when dealing with hydraulic fluid under pressure. Relieve pressure in the system before removing hoses, fittings, gauges, or components. Never use your hand or any other body part to check for leaks in a pressurized line. Seek medical attention immediately if you are cut by hydraulic fluid.

---

#### Personal safety

 **Warning**

---

Protect yourself from injury. Use proper safety equipment, including safety glasses, at all times.

---

## Introduction

### Warranty

Performing installation, maintenance, and minor repairs according to the procedures in this manual will not affect your warranty. Major repairs requiring the removal of a unit's endcap voids the warranty unless done by a Danfoss Global Service Partner.

### Symbols used in Danfoss literature

	WARNING may result in injury		Tip, helpful suggestion
	CAUTION may result in damage to product or property		Lubricate with hydraulic fluid
	Reusable part		Apply grease / petroleum jelly
	Non-reusable part, use a new part		Apply locking compound
	Non-removable item		Inspect for wear or damage
	Option - either part may exist		Clean area or part
	Superseded - parts are not interchangeable		Be careful not to scratch or damage
	Measurement required		Note correct orientation
	Flatness specification		Mark orientation for reinstallation
	Parallelism specification		Torque specification
	External hex head		Press in - press fit
	Internal hex head		Pull out with tool – press fit
	Torx head		Cover splines with installation sleeve
	O-ring boss port		Pressure measurement/gauge location or specification

The symbols above appear in the illustrations and text of this manual. They are intended to communicate helpful information at the point where it is most useful to the reader. In most instances, the appearance of the symbol itself denotes its meaning. The legend above defines each symbol and explains its purpose.

### General description

Danfoss Series 45 Frame F open circuit piston pumps convert input torque into hydraulic power. The input shaft transmits rotational force from the prime mover to the cylinder block. Tapered roller bearings support the shaft at the front and rear of the pump. The cylinder block connects to the input shaft through splines on the shaft. A lip-seal at the front end of the pump prevents leakage where the shaft exits the pump housing. The spinning cylinder block contains nine reciprocating pistons. Each piston has a brass slipper connected at one end by a ball joint. The slippers are held to the swashplate by the spring retainer and block spring. The block spring also holds the cylinder block to the valve plate. The reciprocating movement of the pistons occurs as the slippers slide against the inclined swashplate during rotation. The valve plate connects one half of the cylinder block to pump inlet and the other half to pump outlet. As each piston cycles in and out of its bore, fluid is drawn from the inlet and displaced to the outlet thereby imparting power into the system circuit. A small amount of fluid leaks from the cylinder block / valve plate and slipper / swashplate interfaces for lubrication and cooling. Case drain ports return this fluid to the reservoir.

The angle of the swashplate controls the volume of fluid displaced into the system circuit. The bias piston forces the swashplate into an inclined position (into stroke). The servo piston opposes the action of the

## Introduction

bias piston and spring, forcing the swashplate out of stroke when hydraulic pressure in the control circuit rises above the spring force.

The pump control, by varying the pressure at the servo piston, controls the displacement of fluid in the system circuit. Controls designed for **P**ressure **C**ompensation (PC) or **L**oad **S**ensing (LS) are available. For a detailed description of control operation, refer to [General](#) on page 12.

### *Pump and control sectional view*

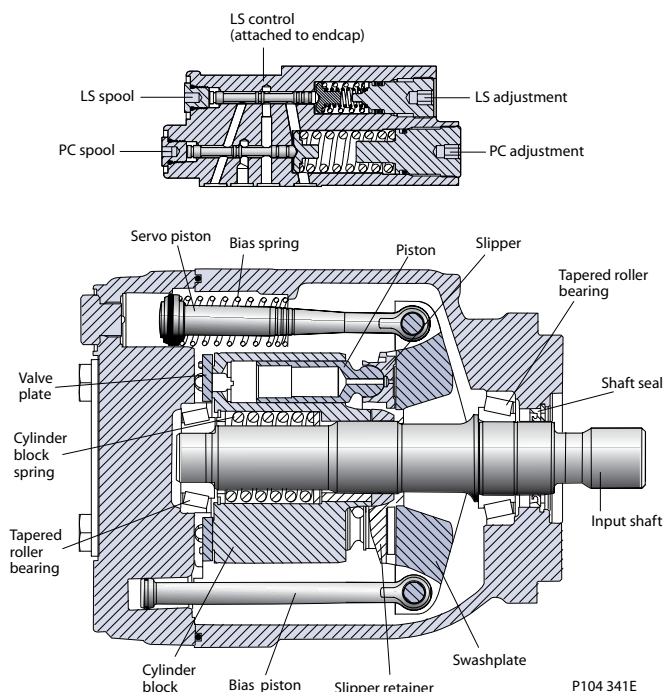

## System circuit

The pump receives fluid directly from the reservoir through the inlet line. A screen in the inlet line protects the pump from large contaminants. The pump outlet feeds a PVG-32 multi-section, load sensing, directional control valve. The PVG valve directs pump flow to the cylinder and gear motor. A heat exchanger cools the fluid returning from the valve. A filter cleans the fluid before it returns to the reservoir.

Flow in the circuit determines the speed of the actuators. The position of the PVG valve determines the flow demand. A hydraulic pressure signal (LS signal) communicates demand to the pump control. The pump control monitors the pressure differential between pump outlet and the LS signal, and regulates servo pressure to control the swashplate angle. Swashplate angle determines pump flow.

Actuator load determines system pressure. The pump control monitors system pressure and will decrease the swashplate angle to reduce flow if system pressure reaches the PC setting. A system relief valve in the PVG valve acts as a back-up to control system pressure.

**Introduction**

*Pictorial circuit diagram*

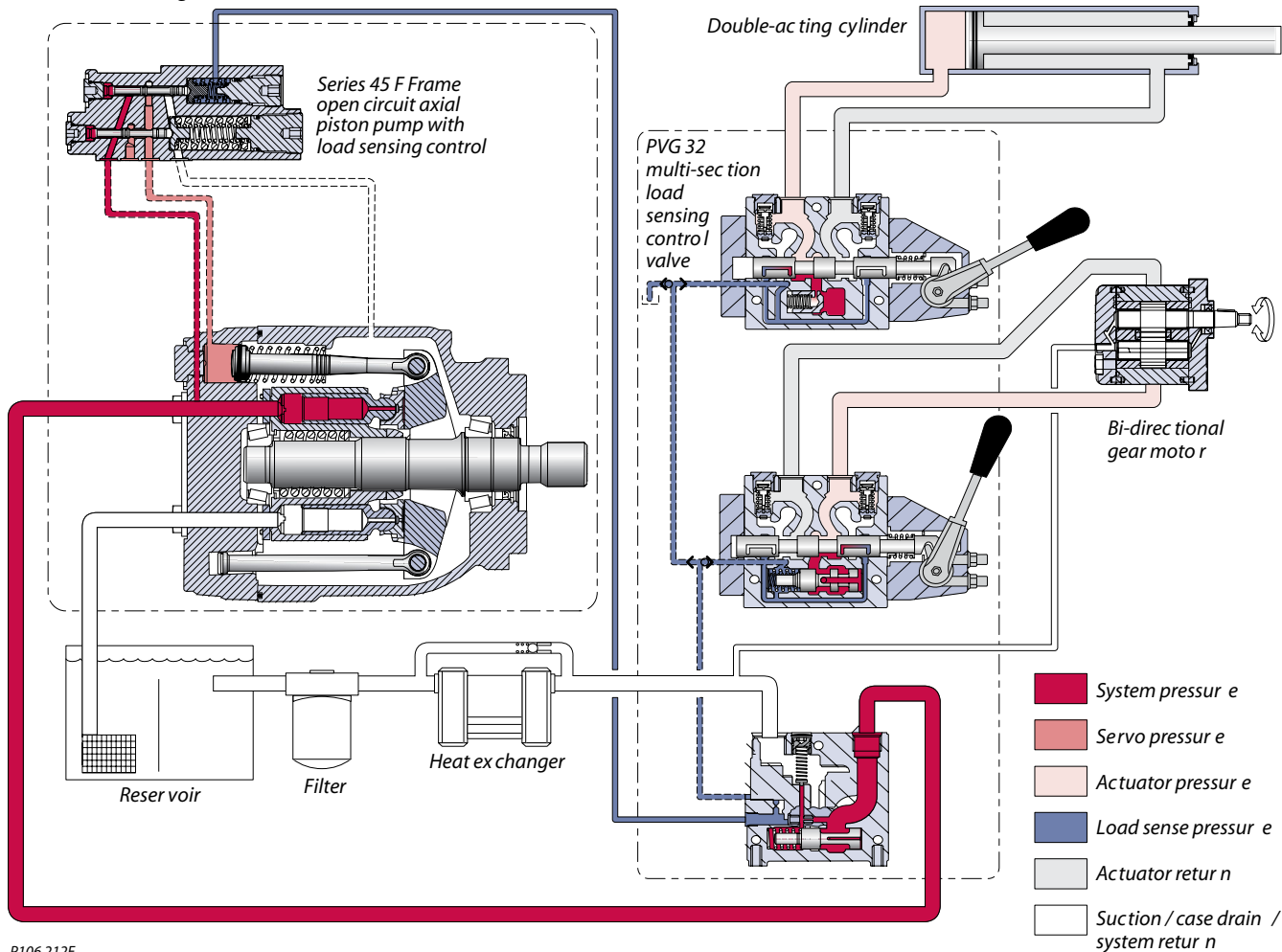

P106 212E

<sup>1</sup>Full available flow is a function of pump displacement, operating speed, and efficiency. Refer to *Series 45 Axial Piston Open Circuit Pumps Technical Information, 520L0519* for details.

## Technical specifications

### General specifications

#### Type of mounting

SAE-C mounting flange.

#### Auxiliary mounting pad options

SAE-A, SAE-B, SAE-B-B, SAE-C, SAE C-C

#### Control options

PC: Pressure Compensator

LS: Load Sensing (with PC)

#### Port options

Inlet and system ports: SAE flanged ports, code 61 Inlet Code 62 outlet. Axial (end) ports or radial (side) ports.

All other ports: SAE straight thread O-ring boss.

#### Direction of rotation

Clockwise or counterclockwise.

#### Installation position

Installation position is discretionary. To satisfy inlet pressure conditions, we recommend you locate the pump below the lowest level of hydraulic fluid in the reservoir. The housing must always be filled with hydraulic fluid.

### Technical specifications

#### Features and options

Model		F74B	F90C
Feature	Unit		
Maximum displacement	cm <sup>3</sup> [in <sup>3</sup> ]	74 [4.52]	90 [5.49]
Flow at rated speed (theoretical)	l/min [US gal/min]	177.6 [46.9]	198 [52.3]
Input torque at maximum displacement (theoretical)	N•m/bar [lbf•in/1000 psi]	1.178 [719]	1.432 [874]
Mass moment of inertia of internal rotating components	kg•m <sup>2</sup> [slug•ft <sup>2</sup> ]	0.00630 [0.00465]	0.00650 [0.00480]
Weight	Axial ports	kg [lb]	29 [63]
	Radial ports		
Rotation		Clockwise, Counterclockwise	
Mounting		SAE B 2 blot, SAE-C 4 bolt	
Auxiliary mounting		SAE-A, SAE-B, SAE-BB, SAE-C	
System ports (type)		4-bolt split flange	
System ports (location)		Axial, Radial	
Control types		PC, Remote PC, LS, Electric	

**Technical specifications**
*Features and options (continued)*

Model		F74B	F90C
Shafts	Splined	14 tooth, 17 tooth	
	Straight	Ø 31.75 mm [1.25 in]	
Displacement limiters		Optional, adjustable	

*Ratings*

Model			G74B	G90C
Rating		Units		
Input speed <sup>1</sup>	minimum	min <sup>-1</sup> (rpm)	500	500
	continuous		2400	2200
	maximum		2800	2600
Working pressure	continuous	bar [psi]	310 [4495]	260 [3770]
	maximum		400 [5800]	350 [5075]
External shaft loads	External moment (Me)	N·m [lbf·in]	300 [2655]	
	Thrust in (Tin), out (Tout)	N [lbf]	2900 [650]	
Bearing life	at 140 bar [2030 psi]	B10 hours	31 300	17 400
	at 210 bar [3045 psi]		1110	5700
	at 260 bar [3770 psi]		4810	2490
	at 310 bar [4495 psi]		3080	1636
Mounting flange load moments	Vibratory (continuous)	N·m [lbf·in]	3730 [33 000]	
	Shock (maximum)		13 220 [117 000]	

<sup>1</sup>Input speeds are valid at 1 bar absolute [0 in Hg vac] inlet pressure. See Inlet pressure vs. speed charts.

**Hydraulic parameters**
**Inlet pressure**

Minimum pressure, continuous = 0.8 bar absolute [6.7 inch Hg vacuum]

(at reduced maximum pump speed)

Minimum pressure, cold start = 0.5 bar absolute [15.1 inch Hg vacuum]

**Pressure compensator valve setting**
*PC control setting range*

Model	bar	psi
F74B	100–310	1450–4495
F90C	100–260	1450–3770

**Case pressure**

Maximum continuous: 0.5 bar [7 psi] above inlet

Intermittent: 2 bar [29 psi] cold start

## Technical specifications

### Hydraulic fluid

Refer to Danfoss publication: *Fluids and Filtration 520L0463*. For information on biodegradable fluids refer to *Biodegradable Hydraulic Fluids, 520L0465*. See *Fluid and filter maintenance* section for recommended fluid and filter change intervals.

### Temperature range

#### Temperature limits

<b>Minimum (intermittent, cold start)</b>	- 40° C [- 40° F]
<b>Continuous<sup>1</sup></b>	82° C [180° F]
<b>Maximum<sup>2</sup></b>	104° C [220° F]

<sup>1</sup> Hydraulic fluid viscosity must be maintained within the prescribed limits.

<sup>2</sup> As measured at the hottest point in the system, e.g. drain line.

### Fluid viscosity

#### Fluid viscosity limits

Condition		mm <sup>2</sup> /s (cSt)	SUS
v min.	continuous	9	58
	intermittent	6.4	47
v max.	continuous	110	500
	intermittent (cold start)	1000	4700

### Filtration

Required cleanliness level: ISO 4406 Class 18/13 or better. Refer to Danfoss publications *Fluids and Filtration 520L0463* and *Design Guidelines for Selecting and Maintaining the Required Hydraulic Fluid Cleanliness 520L0465*. See *Fluid and filter maintenance* section for recommended fluid and filter change intervals.

## Features

### Displacement limiter

Frame F Series 45 pumps are available with an optional adjustable maximum displacement limiter. The adjustable stop limits the pump's maximum displacement. The displacement change per turn is 6.8 cm<sup>3</sup>/turn [0.47 in<sup>3</sup>/turn] for the F90C and 6.0 cm<sup>3</sup>/turn [6.1 in<sup>3</sup>/turn] for the F74B

#### Displacement limiter

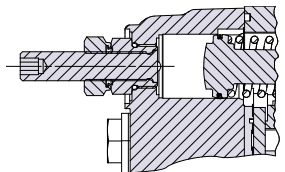

P104 345

### Auxiliary mounting pads

Auxiliary mounting pads are available for all radial ported Series 45 pumps. These pads are typically used for mounting auxiliary hydraulic pumps.

Since the auxiliary pad operates under case pressure, you must use an O-ring to seal the auxiliary pump mounting flange to the pad. Oil from the main pump case lubricates the drive coupling. For details refer to *Series 45 Axial Piston Open Circuit Pumps Technical Information 520L0519*.

#### Auxiliary pad options

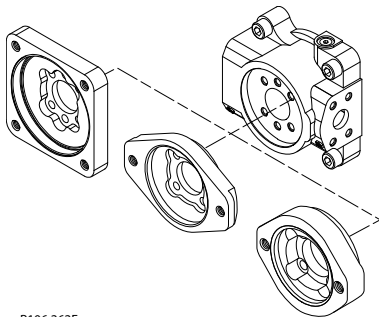

P106 262E

### Input shafts

Series 45 F Frame pumps are available with a variety of splined and straight keyed shafts. For information on shafts refer to *Series 45 Axial Piston Open Circuit Pumps Technical Information 520L0519*.

### Control options

The Series 45 Frame F pumps have two control options, a **Load Sensing (LS)** control with **Pressure Compensator (PC)** or a **PC only** control.

#### General

The bias piston and spring (1&2) acts at all times to push the swashplate (4) to maximum angle causing the pump to stroke. The servo piston (3) acts against the bias piston and spring to reduce the swashplate angle causing the pump to destroke. Swashplate angle determines pump outlet flow. The pump control, depending on conditions in the system circuit, sets swashplate angle by metering system pressure to the servo piston.

**Features**

*Cross-section pump*

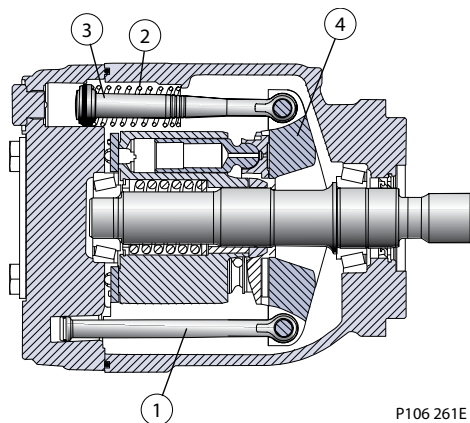

Bias spring and servo piston set swashplate position

**PC control**

The PC control design maintains a constant pressure in the hydraulic circuit as flow varies. The PC control modulates pump flow accordingly to maintain system pressure at the PC setting as the PC adjusting plug (4) and spring (5) define.

When system pressure, acting on the non-spring end of the PC spool (6), overcomes the force of the PC spring (5), the spool shifts porting system pressure to the servo piston and the swashplate angle decreases. When system pressure drops below the PC setting, the PC spring shifts the spool in the opposite direction connecting the servo piston to pump case and the swashplate angle increases. The swashplate is maintained at whatever angle is required to keep system pressure at the PC setting.

*Cross-section PC control*

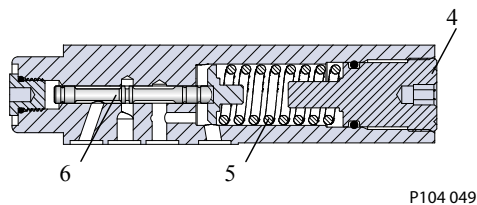

PC spool shifts to port system pressure to servo piston

**LS control**

The LS control design matches pump flow with system demand. The LS control senses the flow demand of the system as a pressure drop across the External Control Valve (ECV). As the ECV opens and closes, the pressure delta across the valve changes. When opening, the delta decreases. When closing, the delta increases. The LS control then increases or decreases pump flow to the system until the pressure delta becomes equal to the LS setting as defined by the LS adjusting plug (7) and spring (8).

**Features**

*Typical load-sensing control valve*

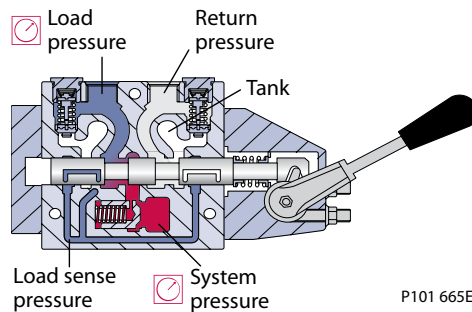

Pressure drop across external control valve defines system demand

*Cross-section LS control*

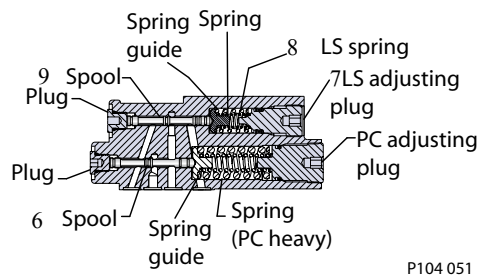

LS spool shifts to port system pressure to servo piston

The LS control consists of two spool valves that connect the servo piston either to pump case or system pressure. The PC spool (6) controls the pressure-compensating function of the control as previously described. The LS spool (9) controls the load-sensing function. The PC spool has priority over the LS spool.

Through internal porting, system pressure (upstream of ECV) is applied to the non-spring end of the LS spool, and through hydraulic line connected at port X, LS pressure (downstream of ECV) is applied to the spring end. This arrangement allows the LS spool to act on the delta between system pressure and LS pressure. The LS spring sets the threshold of operation (LS setting).

Because the swashplate is biased to maximum angle, the pump attempts to deliver full flow to the hydraulic system. When the flow being delivered exceeds demand, the pressure delta across the ECV is great enough to overcome spring force and shift the LS spool porting system pressure to the servo piston. The pump de-strokes reducing flow until the delta across the ECV becomes equal to the LS setting. When flow being delivered is less than demand, the delta across the ECV drops below the LS setting and the LS spring shifts the spool connecting the servo piston to pump case. The pump strokes increasing flow until the delta across the ECV becomes equal to the LS setting.

When the external control valve is placed in neutral, it connects the LS signal line to drain. With no LS pressure acting on the non-spring end of the LS spool, the pump adjusts stroke to whatever position necessary to maintain system pressure at the LS setting. The pump is now in standby mode.

Because of the series arrangement of the LS and PC spools, the PC spool will override the LS spool. If at any time system pressure reaches the PC setting, the PC spool will shift blocking the passage that connects the LS spool with the servo piston, thus porting system pressure to the servo piston causing the pump to destroke.

**Electric Proportional Controls**

All Series 45 Electric controls have met and passed the Danfoss PLUS+1 compliance standard testing, and as such, this Series 45 control is PLUS+1 compliant. PLUS+1 compliance blocks are available on the Danfoss website, within the PLUS+1 Guide section.

**Features**



**COMPLIANT**

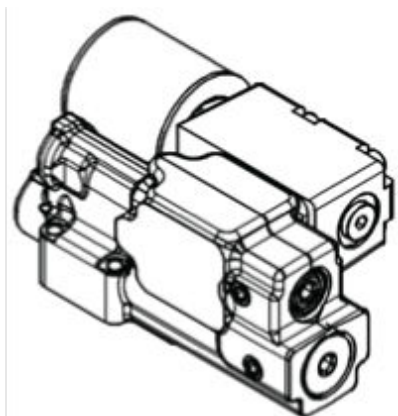

**Electric Proportional Control Principle**

The Electric Proportional Control consists of a proportional solenoid integrated into a Remote Pressure Compensated control. This control allows the pump to be operated at any pressure limit between the Load Sense and Pressure Compensation settings by varying the current sent to the solenoid.

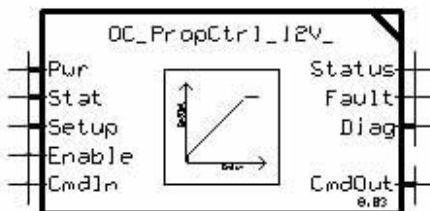

**Electric On/Off Controls**

All Series 45 Electric controls have met and passed the Danfoss PLUS+1 compliance standard testing, and as such, this Series 45 control is PLUS+1 compliant. PLUS+1 compliance blocks are available on the Danfoss website, within the PLUS+1 Guide section.



**COMPLIANT**

**Features**

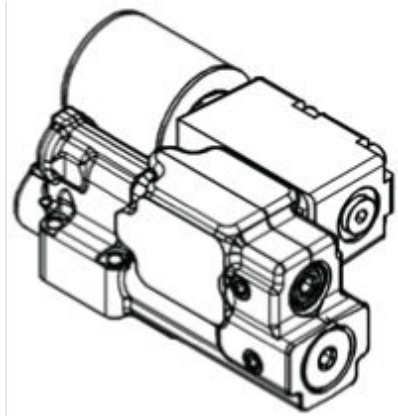

**Electric On-Off Control Principle**

The Electric On/Off Control consists of an On/Off solenoid integrated into a Remote Pressure Compensated control. This control allows the pump to be operated at either the Load Sense pressure setting when **On**, or the Pressure Compensation pressure setting when **Off**.

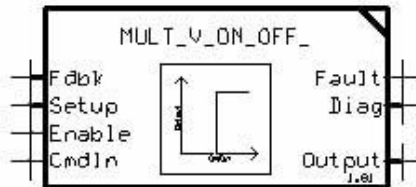

**Fan Drive Control (FDC)**

**PLUS+1 Compliance**

All Series 45 Electric controls have met and passed the Danfoss PLUS+1 compliance standard testing, and as such, this Series 45 control is PLUS+1 compliant. PLUS+1 compliance blocks (software) are available on the Danfoss website, within the PLUS+1 Guide section.

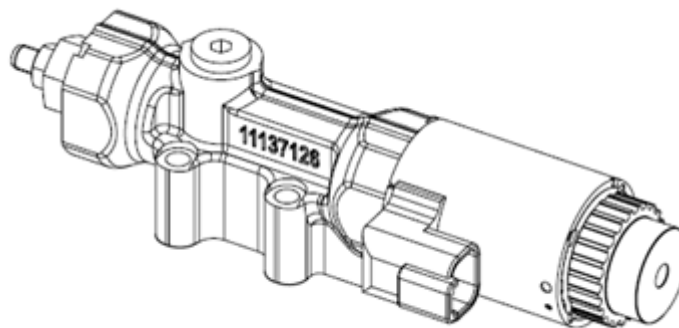

## Features

### Fan Drive Control Principle

The Fan Drive Control is a unique electrically actuated pressure control solution that consists of a normally closed proportional solenoid and one dual diameter spool sliding in the control housing. System pressure acts on an area between the two spool diameters of the spool lands. This hydraulic force is balanced with forces of springs and the solenoid when the spool is in the metering position. When no current is sent to the solenoid it operates the pump at or below the PC setting which is adjusted mechanically with the adjustor screw and lock nut. Increasing the control current proportionally reduces the pump's outlet pressure until a minimum standby pressure is reached.

Control Block 12V and 24V

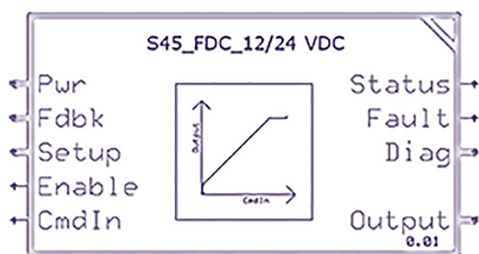

The minimum system pressure is given by swashplate moments of the pump and by servo system leakages which produce a pressure drop across the control. In addition, fan motor type and fan inertia impact minimum system pressure.

The Normally Closed Fan Drive Control coupled with a microprocessor allows the pump to operate at an infinite range of operating pressures between a minimum system pressure and PC setting.

We recommend that a relief valve be installed in the pump outlet for additional system protection.

### Warning

The Fan Drive Control is intended for fan drive systems only! Use in other systems could result in system component damage or unintended machine movement. The Fan Drive Control is not intended to serve at the primary system pressure relief. Loss of the input signal to this control will cause the pump to produce maximum flow.

### S45 pump with integrated FDC control schematic

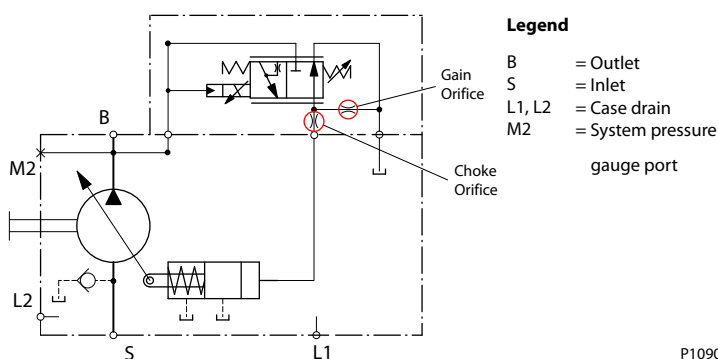

### Electronic Torque Limiting Controls (ETL)

**Features**

***PLUS+1 Compliance***

All Series 45 Electric controls have met and passed the Danfoss PLUS+1 compliance standard testing, and as such, this Series 45 control is PLUS+1 compliant. PLUS+1 compliance blocks (software) are available on the Danfoss website, within the PLUS+1 Guide section.

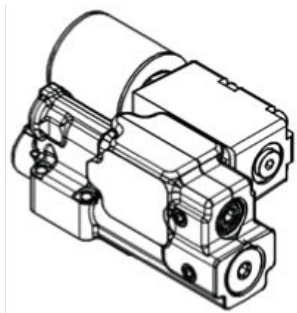

***Electric Torque Limiting Control Principle***

The Electronic Torque Limiting control consists of a normally closed proportional relief valve (PRV) integrated into a Pressure Compensated/Load Sensing control. This control operates as a PC/LS control, with the additional ability to limit load sense pressure using the integrated PRV by varying the current to the solenoid. When combined with an angle sensor, this control allows for a PC/LS control with electronic torque limiting.

*F Frame pump ETL*

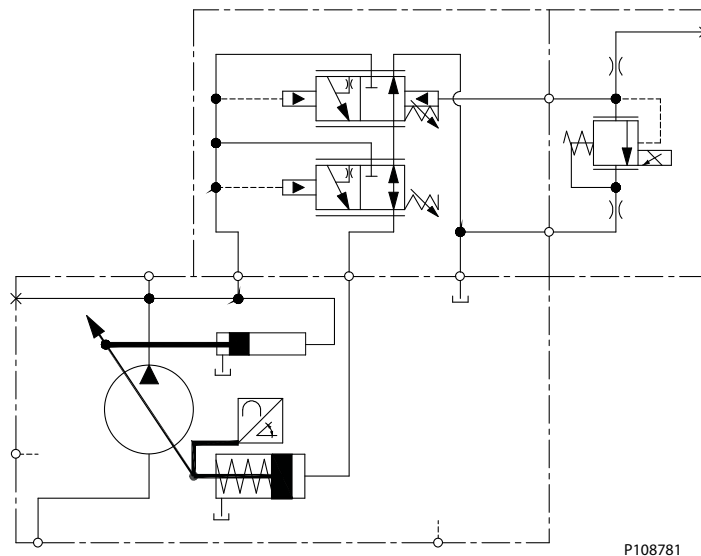

Pump torque consumption is a function of pump outlet pressure, pump displacement, and pump mechanical efficiency. When pump mechanical efficiency is considered constant, the pump torque can be limited when pump displacement is known and pump pressure is controlled. As pump displacement increases, the pump outlet pressure can be limited using the PRV to result in a constant torque limit. Pump outlet pressure is equal to the load sense pressure, which is limited with the PRV, plus the margin pressure setting of the pump.

**Features**

$$\text{Torque} = \frac{\text{Pump Outlet Pressure (bar)} * \text{Pump Displacement} \left(\frac{\text{cc}}{\text{rev}}\right)}{62.8 * \text{Pump Mechanical Efficiency (\%)}}$$

**Pressure measurement**

**Required tools**

The service procedures described in this manual can be performed using common mechanic's hand tools.

- Special tools, if required are shown
- Calibrate pressure gauges frequently to ensure accuracy
- Use snubbers to protect gauges

**Port locations and gauge installation**

The illustration below shows gauge port locations. Recommended pressure gauges and fittings are in the table.

*Gauge and port information*

Port	Purpose	Range of gauge	Fitting
M2	System pressure	0-300 bar [0-5000 psi]	9/16 - 18 O-ring fitting
M4	Servo pressure	0-300 bar [0-5000 psi]	9/16 - 18 O-ring fitting
L1, L2	Case pressure	0-10 bar [0-100 psi]	7/8 - 14 O-ring fitting
X1	LS signal	0-300 bar [0-5000 psi]	7/16 - 20 O-ring fitting (tee into LS signal line)

*Gauge port locations*

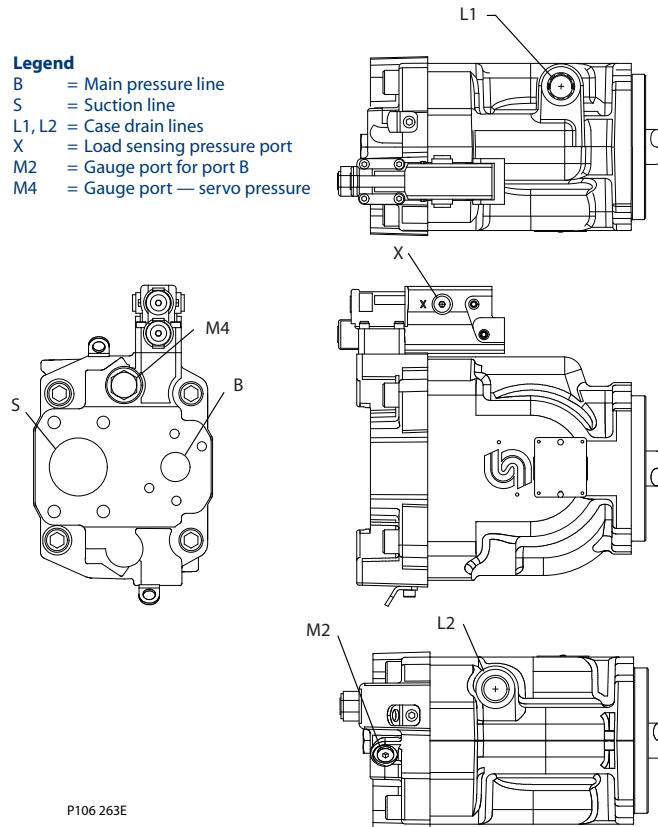

## Initial Start-Up Procedures

### General

Follow this procedure when starting-up a new Series 45 installation or when restarting an installation in which the pump has been removed.

**⚠ Warning**

Unintended movement of the machine or mechanism may cause injury to the technician or bystanders. To protect against unintended movement, secure the machine or disable/disconnect the mechanism while servicing.

---

Prior to installing the pump, inspect for damage incurred during shipping. Make certain all system components (reservoir, hoses, valves, fittings, heat exchanger, etc.) are clean prior to filling with fluid.

### Start-up procedure

1. Connect the pump to the prime mover. Ensure that pump shaft is properly aligned with the shaft of the prime mover.

**! Caution**

Incorrect shaft alignment may result in damage to drive shaft, bearings, or seal which can cause external oil leakage.

---

2. Fill the reservoir with recommended hydraulic fluid. Always filter fluid through a 10 micron filter pouring into the reservoir. Never reuse hydraulic fluid.
3. Fill the main pump housing with clean hydraulic fluid. Pour filtered oil directly into the upper most case drain port.
4. Fill the inlet line leading from the pump to the reservoir. Check the inlet line for properly tightened fittings and be certain it is free of restrictions and air leaks.
5. To ensure the pump stays filled with oil, install the case drain line in the upper most case drain port.
6. Install a gauge at the system pressure gauge port to monitor system pressure during start up.

[Follow recommendations in the vehicle/machine operator's manual for prime mover start up procedures.](#)

---

7. While watching the pressure gauge installed at the system pressure gauge port, jog the prime mover or run at the lowest possible speed until system pressure builds to normal levels (minimum 11 bar [160 psi]). Once system pressure is established, increase to full operating speed. If system pressure is not maintained, shut down the prime mover, determine cause, and take corrective action. Refer to the *Troubleshooting* chapter.
8. Operate the hydraulic system for at least fifteen minutes under light load conditions.
9. Check and adjust control settings as necessary after installation. Refer to the *Adjustments* chapter.
10. Shut down the prime mover and remove the pressure gauge. Replace the plug at the system pressure gauge port.
11. Check the fluid level in the reservoir; add clean filtered fluid if necessary.

The pump is now ready for operation.

**Fluid and Filter Maintenance****Recommendations**

To ensure optimum life of Series 45 products, perform regular maintenance of the fluid and filter. Contaminated fluid is the main cause of unit failure. Take care to maintain fluid cleanliness when servicing.

Check the reservoir daily for proper fluid level, the presence of water, and rancid fluid odor. Water in the fluid may be noted by a cloudy or milky appearance or free water in the bottom of the reservoir. Rancid odor indicates the fluid has been exposed to excessive heat. Change the fluid immediately if these conditions occur. Correct the problem immediately.

Change the fluid and filter per the vehicle/machine manufacturer's recommendations or at these intervals:

Change the fluid more frequently if it becomes contaminated with foreign matter (dirt, water, grease, etc.) or if the fluid is subjected to temperature levels greater than the recommended maximum.

---

[Dispose of used hydraulic fluid properly. Never reuse hydraulic fluid.](#)

---

Change filters whenever the fluid is changed or when the filter indicator shows that it is necessary to change the filter. Replace all fluid lost during filter change.

*Fluid and filter change interval*

<b>Reservoir type</b>	<b>Maximum change interval</b>
Sealed	2000 hours
Breather	500 hours

## Troubleshooting

### Excessive noise and/or vibration

Item	Description	Action
Check fluid level in reservoir.	Insufficient hydraulic fluid causes cavitation.	Fill the reservoir to proper level.
Check for air in system.	Air in system causes noisy, erratic control.	Purge air and tighten fittings. Check inlet for leaks.
Check pump inlet pressure/vacuum.	Improper inlet conditions cause erratic behavior and low output flow.	Correct pump inlet pressure / vacuum conditions. Refer to the <i>Hydraulic Parameters</i> topic.
Inspect shaft couplings.	A loose or incorrect shaft coupling causes excessive noise and/or vibration.	Repair or replace coupling and ensure that correct coupling is used.
Check shaft alignment.	Misaligned shafts create excessive noise and/or vibration.	Correct shaft misalignment.
Hydraulic fluid viscosity above acceptable limits.	Hydraulic fluid viscosity above acceptable limits or low fluid temperature will not allow the pump to fill or control to operate properly.	Allow system to warm up before operating, or use fluid with the appropriate viscosity grade for expected operating temperatures. See <i>Hydraulic Fluids and Lubricants Technical Information Manual</i> , <b>520L0463</b> .

### Actuator response is sluggish

Item	Description	Action
Check external system relief valve setting.	Low external relief valve setting slows down system.	Adjust external relief valve setting following manufacturer's recommendations. External relief setting must be above PC setting to operate properly.
Check PC and LS control setting.	Low PC setting prevents the pump from achieving full stroke. Low LS setting limits output flow.	Adjust PC and LS setting. Refer to the <i>Adjustments</i> chapter.
Check LS control signal pressures.	Incorrect LS signal will not allow pump to operate correctly.	Inspect system to ensure that proper LS signal transmit to pump.
Internal system leaks.	Worn internal parts don't allow the pump to operate properly.	Refer to Authorized Service Center for required repair.
Hydraulic fluid viscosity above acceptable limits.	Hydraulic fluid viscosity above acceptable limits or low fluid temperature will not allow the pump to fill or control to operate properly.	Allow system to warm up before operation or use fluid with the appropriate viscosity grade for expected operating temperatures. See <i>Hydraulic Fluids and Lubricants Technical Information Manual</i> , <b>520L0463</b> .
Check external system valving.	Malfunctioning valving may not allow system to respond properly.	Repair or replace system valving as required.
Check pump case pressure.	High case pressure causes the system to be sluggish.	Correct case drain line restrictions.
Check pump inlet pressure/vacuum.	High inlet vacuum causes low output flow.	Correct inlet pressure conditions.

### System operating hot

Item	Description	Action
Check fluid level in reservoir.	Insufficient volume of hydraulic fluid will not meet cooling demands of system.	Fill reservoir to proper level. Verify proper size of reservoir.
Inspect heat exchanger. Check air flow and input air temperature for the heat exchanger.	Insufficient air flow, high input air temperature, or undersized heat exchangers will not meet cooling demands of the system.	Clean, repair, or replace heat exchanger as required. Verify proper size of heat exchanger.

## Troubleshooting

Item	Description	Action
Check external system relief valve setting.	Fluid passing through relief valve adds heat to system.	Adjust external system relief valve setting following manufacturer's recommendations. External relief valve setting must be above PC setting for proper operation.
Check pump inlet pressure/vacuum.	High inlet vacuum adds heat to system.	Correct inlet pressure/vacuum conditions.

### Low pump output flow

Item	Description	Action
Check fluid level in reservoir.	Insufficient hydraulic fluid will limit output flow and cause internal damage to pump.	Fill the reservoir to proper level.
Hydraulic fluid viscosity above acceptable limits.	Fluid viscosity above acceptable limits or low fluid temperature will not allow the pump to fill or control to operate properly.	Allow system to warm up before operating, or use fluid with the appropriate viscosity grade for expected operating temperatures. See <i>Hydraulic Fluids and Lubricants Technical Information Manual</i> , <b>520L0463</b> .
Check external system relief valve setting.	External relief valve set below PC setting causes low output flow.	Adjust external relief valve following manufacturer's recommendation. External relief valve setting must be above PC setting to operate properly.
Check PC and LS control setting.	Low PC setting prevents the pump from achieving full stroke.	Adjust PC and LS setting. Refer to the <i>Adjustments</i> chapter.
Check pump inlet pressure/vacuum.	High inlet vacuum causes low output flow.	Correct inlet pressure conditions.
Check input speed.	Low input speeds decrease flow.	Adjust input speed.
Check pump rotation.	Incorrect rotational configuration causes low flow.	Use pump with appropriate rotational configuration.

### Pressure or flow instability

Item	Description	Action
Check for air in system.	Air in system causes erratic operation.	Activate PC allowing system to bleed air. Check inlet line for leaks and eliminate source of air ingress.
Check control spools.	Sticking control spools cause erratic operation.	Inspect spools for free movement in bore. Clean or replace.
Check LS setting.	Low LS setting may cause instability.	Adjust LS setting to proper level. See the <i>Adjustments</i> chapter.
Check LS signal line.	Blocked LS signal line interferes with proper LS operation.	Remove blockage.
Check external relief valve and PC setting.	Insufficient pressure differential between PC setting and external relief valve.	Adjust external relief valve or PC control settings to appropriate level. Relief valve setting must be above PC setting to operate properly.
Check external relief valve.	Chattering external relief valve may cause unstable feedback to pump control.	Adjust or replace relief valve.

## Troubleshooting

### System pressure not reaching PC setting

Item	Description	Action
Check PC control setting.	System pressure will not rise above PC setting.	Adjust PC to appropriate setting. Refer to the <i>Adjustments</i> chapter.
Check external relief valve.	External relief valve setting below PC setting presents pressure compensation.	Adjust external relief valve according to manufacturer's recommendations. External relief valve must be set above PC setting to operate properly.
Inspect PC control spring.	Broken, damaged, or missing spring will cause erratic operation.	Replace the spring as required.
Inspect PC spool for wear.	Wear of PC spool causes internal leakage in the control.	Replace the spool as required.
Inspect PC spool for proper orientation.	Improper orientation results in poor operation.	Correct orientation of spool.
Check PC control for contamination.	Contamination may interfere with movement of the PC spool.	Clean PC control components, take appropriate action to eliminate contamination.

### High inlet vacuum

 **Caution**

High inlet vacuum causes cavitation which can damage internal pump components.

Item	Description	Action
Check fluid temperature.	Low temperature increases viscosity. High fluid viscosity causes high inlet vacuum.	Allow system to warm up before operating.
Inspect inlet screen.	Blocked or restricted inlet screen causes high inlet vacuum.	Clean screen/remove blockage.
Check inlet piping.	Too many fittings, bends, or long piping causes high inlet vacuum.	Eliminate fittings to make path more direct.
Hydraulic fluid viscosity above acceptable limits.	High fluid viscosity causes high inlet vacuum.	Select fluid with appropriate viscosity for expected operating temperature. See <i>Hydraulic Fluids and Lubricants Technical Information Manual</i> , <b>520L0463</b> .

## Adjustments

### PC control

PC setting is indicated in the pump model code. Refer to the *Series 45 Open Circuit Axial Piston Pumps Technical Information Manual*, **520L0519**, for more information.

---

Before performing adjustments, read [Pressure measurement](#) on page 20.

---

1. Install a pressure gauge in port M2 to measure system pressure. Install a pressure gauge in case drain port L1 or L2 to measure case pressure.

**⚠ Warning**

Escaping hydraulic fluid under pressure can have sufficient force to penetrate your skin causing serious injury and/or infection. Relieve pressure in the system before removing hoses, fittings, gauges, or components.

---

**⚠ Warning**

Unintended movement of the machine or mechanism may cause injury to the technician or bystanders. To protect against unintended movement, secure the machine or disable / disconnect the mechanism while servicing.

---

**⚠ Caution**

Contamination can damage internal components and void the manufacturer's warranty. Take precautions to ensure system cleanliness when removing and reinstalling system lines.

---

2. Start the prime mover and allow fluid to reach normal operating temperature. Operate a hydraulic function to its full extension, loading the pump to maximum pressure and zero flow.
3. Loosen the PC set screw and turn the PC adjusting plug until the gauge at port M2 indicates the desired setting<sup>1</sup>. Clockwise rotation increases pressure, counterclockwise rotation decreases; approximate gain 42 bar [610 psi] per turn.

---

If the pressure does not increase, an external system relief valve may require adjustment. External system relief valve must be set above the PC setting for proper operation.

---

4. While holding the position of the PC adjusting plug, torque the PC set screw to 9 N•m [7 lbf•ft].

---

<sup>1</sup> PC setting is referenced to case pressure. Subtract case pressure from system pressure to compute the actual setting.

## Adjustments

- Stop the prime mover, remove the pressure gauges, and return the system to its normal operating configuration.

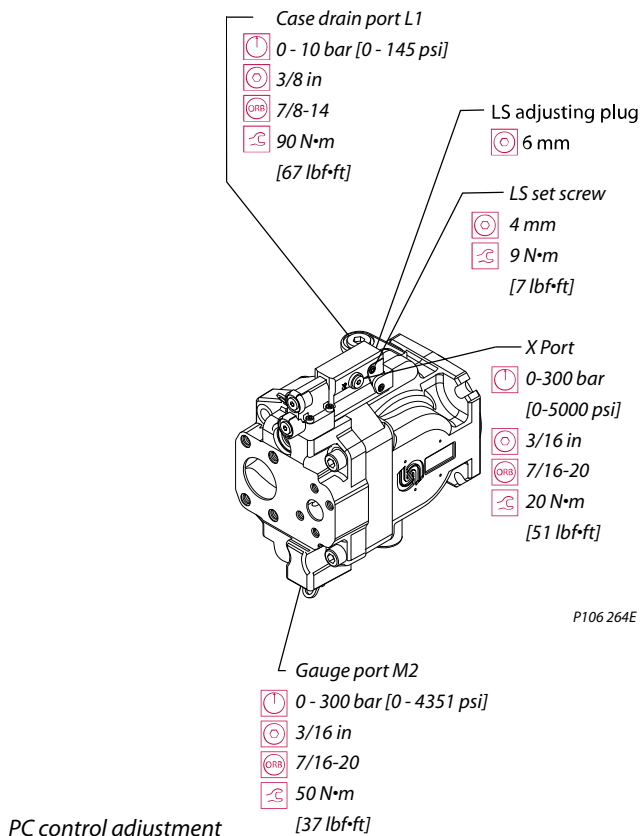

### Pressure change

Control option	PC adjustment	LS adjustment
LS, LD, LB, LE, PC, RP	42 bar/rev [609 PSI/rev]	17.2 bar/rev [250 PSI/rev]
BB, BC, BP, BS	36 bar/rev [534 PSI/rev]	
AB, AC, AD, AJ, AS	8.5 bar/rev [123 PSI/rev]	

## FDC Control

FDC setting is indicated in the pump model code. Refer to the Series 45 Open Circuit Axial Piston Pumps Technical Information Manual, **520L0519**, for more information.

- Install a pressure gauge in port M1 to measure system pressure. Install a pressure gauge in case drain port L1 or L2 to measure case pressure.

### Warning

Escaping hydraulic fluid under pressure can have sufficient force to penetrate your skin causing serious injury and/or infection. Relieve pressure in the system before removing hoses, fittings, gauges, or components.

Unintended movement of the machine or mechanism may cause injury to the technician or bystanders. To protect against unintended movement, secure the machine or disable/disconnect the mechanism while servicing.

## Adjustments

**⚠ Caution**

Contamination can damage internal components and void the manufacturer's warranty. Take precautions to ensure system cleanliness when removing and reinstalling system lines.

2. For more details see also pictorial instruction for FDC PC pressure setting (below).
3. Start the test with the PC adjustment screw turned in 3 revolutions from '0' thread engagement. (PC adjuster fully released - hard stop).  
 FDC Pressure ranges: 100 bar – 310 bar
  - Low pressure spring set: 100-210 bar
    - 3 screw turns from '0' thread engagement, PC pressure is adjusted about 140 bar ± 10 bar (based on spring free length)
    - '0' thread engagement is equal to about 80-100 bar (based on spring free length)
  - High pressure spring set: 220-310 bar
    - 3 screw turns from '0' thread engagement, PC pressure is adjusted about 240 bar ± 10 bar (based on spring free length)
    - '0' thread engagement is is equal to about 180-200 bar (based on spring free length)
4. Disconnect Fan Drive Control signal wire from control. Start the prime mover (or vehicle engine) at maximal allowed speed value and allow fluid to reach normal operating temperature. With the control's signal wire disconnected, the fan drive pump will operate at the pressure value related to the prime mover (vehicle engine) speed value.
5. Loosen the lock nut and turn the PC adjusting screw until the desired the pressure delta between gauge at port M1 and gauge at port L1 or L2 is indicated. Clockwise rotation increases pressure setting, counterclockwise rotation decreases; approximate gain 19.1 bar [277 psi] per turn. (PC sett.= $p_B - p_{case}$  where  $p_B$  = outlet pressure and  $p_{case}$  = case pressure ).

### Control Adjustment - F Frame

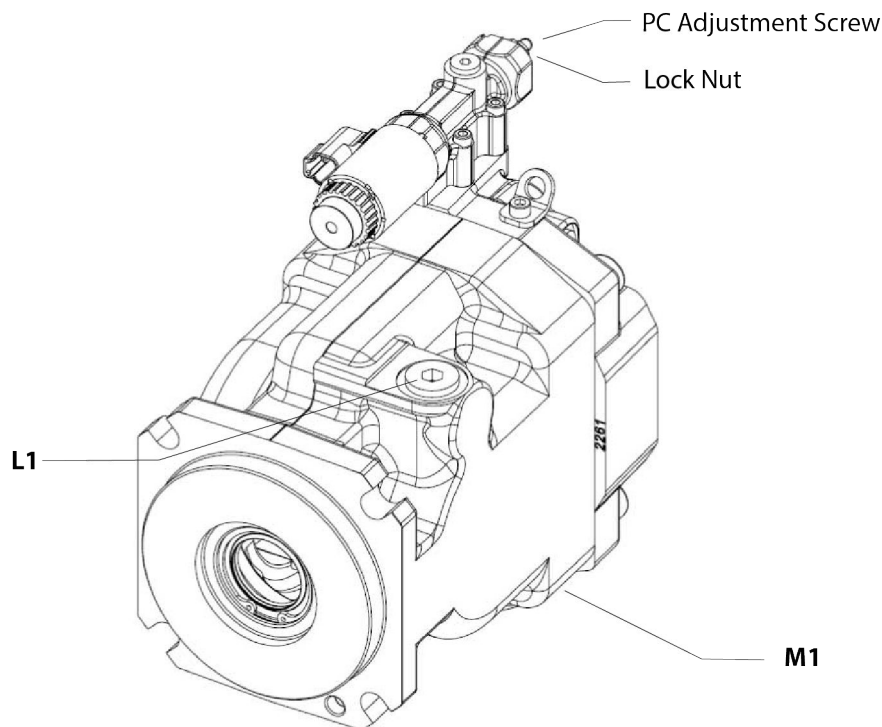

P109032

## Adjustments

### FDC Control Data

Item	Description	Wrench Size	Pressure	Torque
M1	Gauge port	1/4 inch internal hex	0-400 bar [0-5801 psi]	24 Nm [17.7 lbf-ft]
L1	Case drain port	3/8 inch internal hex	0-10 bar [0-100 psi]	95 Nm [70.0 lbf-ft]
Lock Nut	-	12 mm	-	8.5 Nm [6.3 lbf-ft]
Adjusting Screw	-	3 mm internal hex	-	-

### Fan Drive Control pressure setting guidelines

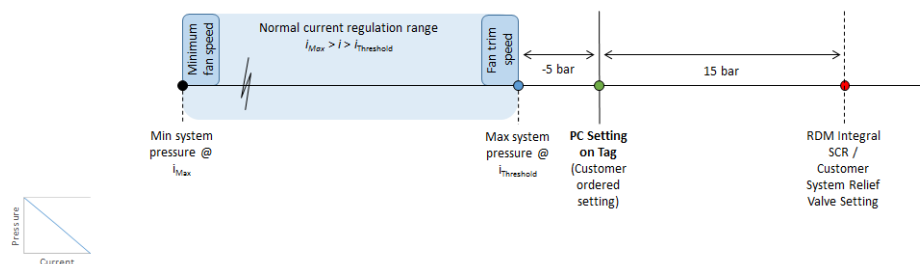

- Design your system's fan trim speed to be reached 5 bar below the PC setting
  - The PC function should not regulate maximum fan speed (maximum system pressure) in a normal duty cycle ( $i_{Max} > i > i_{Threshold}$ )
- This allows the Fan Drive Control's PC setting to fulfill its safety functionality without altering normal fan operation
  - The fan trim speed should be reached at Threshold current
  - Refer to the model order code or the designation on your pump's nametag for your PC setting
- RDM integral SCR or customer installed system pressure reliefs should have 15 bar minimum separation from PC setting
  - This is done to prevent possible 'talking' between the pumps 'PC' function and any other system reliefs
  - Fans should be rated to operate intermittently at the System Relief Valve setting

## LS control

The LS setting is indicated in the pump model code. Refer to the *Series 45 Open Circuit Axial Piston Pumps Technical Information Manual, 520L0519*, for more information.

Before performing adjustments, read [Pressure measurement](#) on page 20

- Install a pressure gauge in port M2 to measure system pressure. Install a pressure gauge in case drain port L1 or L2 to measure case pressure. Tee-in a gauge to the LS / remote PC signal line (port X).

### Warning

Escaping hydraulic fluid under pressure can have sufficient force to penetrate your skin causing serious injury and/or infection. Relieve pressure in the system before removing hoses, fittings, gauges, or components.

### Warning

Unintended movement of the machine or mechanism may cause injury to the technician or bystanders. To protect against unintended movement, secure the machine or disable / disconnect the mechanism while servicing.

Adjustments

**Caution**

Contamination can damage internal components and void the manufacturer's warranty. Take precautions to ensure system cleanliness when removing and reinstalling system lines.

2. Start the prime mover and allow fluid to reach normal operating temperature. Slowly operate a hydraulic function that will demand approximately half flow from the pump, but keep system pressure below the PC set point.
3. Loosen the LS set screw. While watching the pressure gauges, turn the LS adjusting plug until the desired pressure differential between port M2 and port X is achieved<sup>2</sup>. Clockwise rotation increases the setting, counterclockwise rotation decreases it; approximate gain = 17 bar [250 psi] per turn.
4. While holding the position of the LS adjusting plug, torque the LS set screw to 9 N·m [7 lbf·ft].
5. Operate a hydraulic function to its full extension loading the pump at maximum pressure and zero flow.
6. Loosen the PC set screw and turn the PC adjusting plug until the pressure gauge at port M1 or M2 indicates the desired setting<sup>3</sup>. Clockwise rotation increases pressure, counterclockwise rotation decreases it; approximate gain = 42 bar [610 psi] per turn.

If the pressure does not increase, an external system relief valve may require adjustment. External system relief valve must be set above the PC setting for proper operation.

7. While holding the position of the PC adjusting plug, torque the PC set screw to 9 N·m [7 lbf·ft].
8. Stop the prime mover, remove the pressure gauges, and return the system to its normal operating configuration.

LS control adjustment

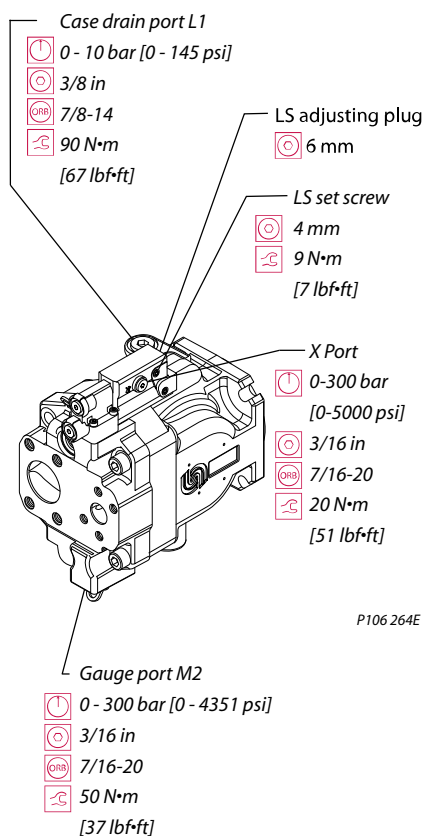

<sup>2</sup> The LS setting is a differential pressure. Subtract pilot pressure at port X from system pressure at port M2 to compute the actual setting.

<sup>3</sup> PC setting is referenced to case pressure. Subtract case pressure from system pressure to compute the actual setting.

## Minor repair

### Shaft seal replacement

The Series 45 open circuit variable pumps use a lip-type shaft seal. You can replace this seal without major disassembly of the unit. Replacing the shaft seal requires removing the pump from the machine.

#### Removal

1. Using the appropriate snap-ring pliers, remove the retaining ring (K010) from the housing.
2. Remove the shaft seal (K020) from the bore in the pump housing and discard. Puncture the face of the seal with a packing hook, or use a slide-hammer type puller to remove the seal.

**! Caution**

Don't damage the pump housing or shaft.

Shaft seal and retaining ring

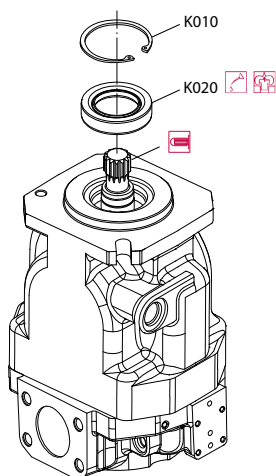

#### Installation

1. Inspect the pump housing and new seal for damage. Inspect the sealing area on the shaft for rust, wear, or contamination. Polish the sealing area on the shaft if necessary.
2. Lubricate the lip of the new shaft seal with clean hydraulic fluid. Place a protective sleeve over the shaft end to prevent damage to the seal during installation.
3. Keeping the seal perpendicular to the shaft, press the new seal into the housing just far enough to clear the retaining ring groove. Install seal with the cupped side toward the shaft bearing. Do not damage the seal during installation.

**! Caution**

Premature bearing failure can result if the shaft seal contacts the shaft bearing. Press the seal into the housing only far enough to clear the retaining ring groove.

4. Using the appropriate snap ring pliers, install the seal retaining ring.
5. Remove the installation sleeve.

### Auxiliary pads

You may install auxiliary mounting pads on pumps equipped with through-drive radial ported end caps. Follow these steps to either remove, replace, or exchange auxiliary mounting pads.

#### Removal

1. Remove the screws (J130), retaining the cover plate (J110) or auxiliary pump (not shown). Remove the shipping cover or auxiliary pump and its seal (J120).

**Minor repair**

2. Remove the drive coupling (J140) if present.
3. Remove the 4 screws (J100) retaining the pad adapter (J080) to the endcap. Discard the pad adapter O-ring (J090) if present.

**Installation**

1. Lubricate new O-rings (J090 and J095) with petroleum jelly. Install the pad adapter to the endcap.
2. Install the 4 screws (J100) and torque to 55 N·m [40 lbf·ft].
3. Install the drive coupling (J140) if present.
4. Install shipping cover or auxiliary pump with seal (J120).

**Caution**

Shipping cover is intended only to retain coupling during shipment and storage. Do not operate pump with coupling and shipping cover installed.

5. Install the screws (J130) and torque to 105 N·m [77 lbf·ft].

*Auxiliary mounting pads*

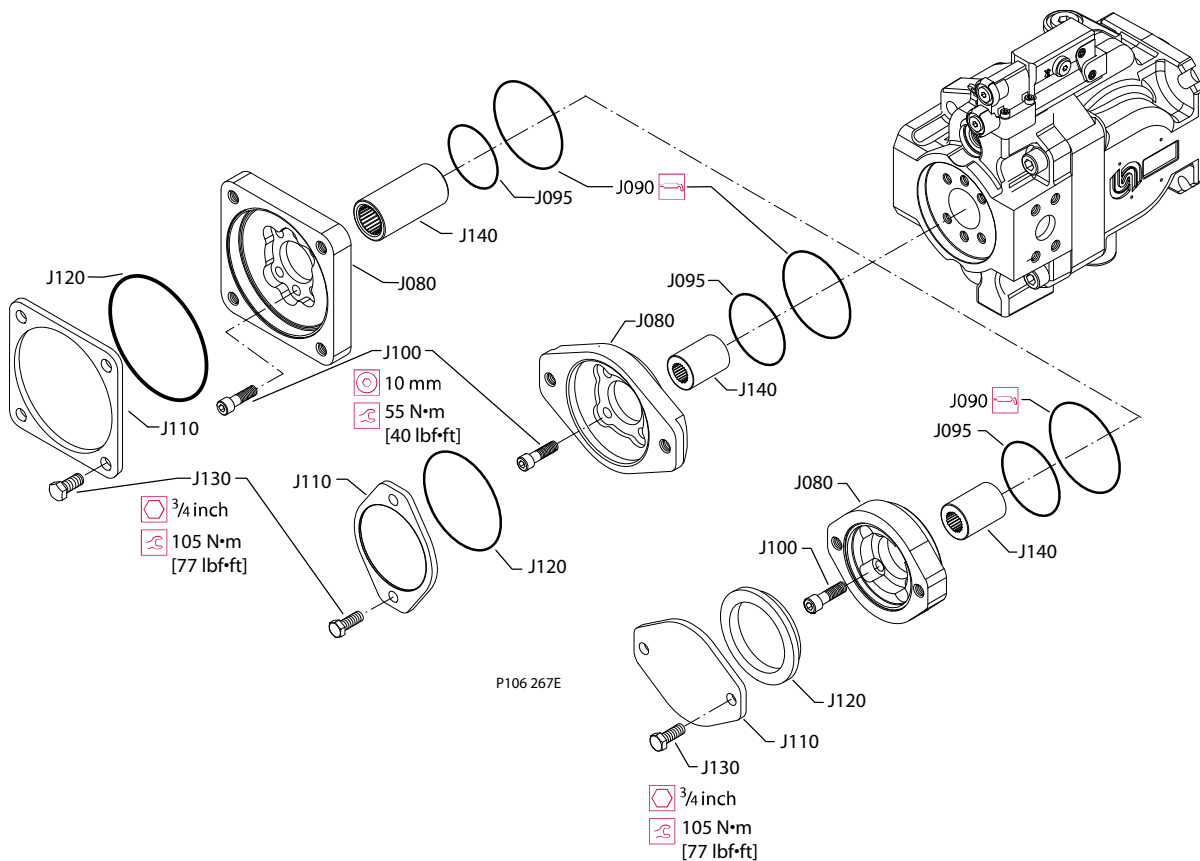

**LS and PC Controls**

**Disassembly**

1. Remove the 4 screws (C300) holding the control housing onto the endcap.
2. Remove the control and discard the 4 interface O-rings (C200).
3. Remove the PC set screw (C102), PC adjusting plug (C138), O-ring (C138A), springs (C134, C135), and seat (C133). Discard the O-ring.

**Minor repair**

4. Remove the plug (C103), O-ring (C103A), and PC spool (C132) from the control housing. Discard the O-ring. Note orientation of the spool for reassembly.

For PC only controls, skip steps 5 through 7

5. Remove the plug (C105) and O-ring (C105A), or the plug (C106) and O-ring (C106A). Discard the O-ring (C105A or C106A).
6. Remove the LS set screw (C102), LS adjusting plug (C118), O-ring (C118A), back-up rings (C118B), springs (C114, C115), and seat (C113). Discard the O-ring and backup rings.
7. Remove the plug (C104), O-ring (C104A), and LS spool (C112) from the control housing; discard the O-ring. Note orientation of the spool for reassembly.

*Control assembly*

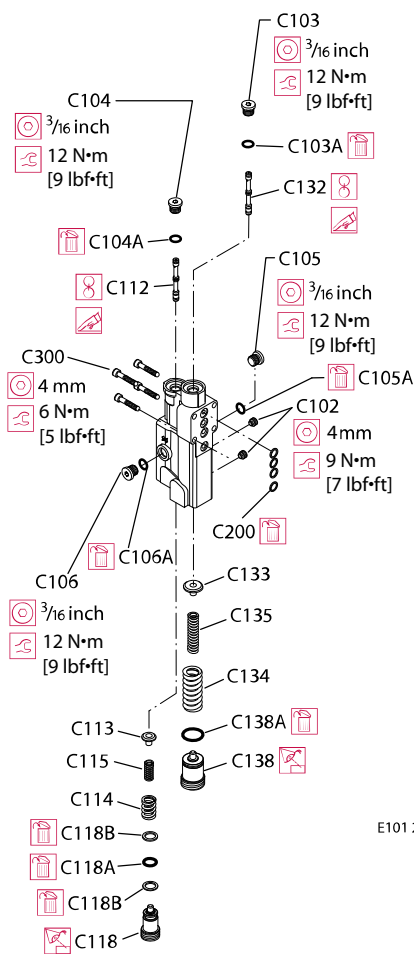

E101 226

LS control shown; parts C104 through C106 and C112 through C118 are not used on PC control

**Inspection**

1. Inspect the adjusting plugs for wear at the tips and where they contact the seat; replace as necessary.
2. Inspect the springs and spring guides for wear or damage; replace as necessary.
3. Carefully inspect the spools. Ensure the sealing lands are free of nicks and scratches. Check the ends that contact the spring guides for wear. Replace spools as necessary.
4. Inspect the control housing for damage. Check the spool bores for excessive wear.
5. Clean all parts and lubricate spools, springs, guides, and new O-rings with clean hydraulic fluid.

Minor repair

Reassembly

1. Install the PC spool (C132), spherical end first, into the PC bore. Using a new O-ring (C103A), install the plug (C103). Torque the plug (C103) to 12 N•m [9 lbf•ft].
2. Place the two PC springs (C134, C135) onto the spring guide (C133) and install into the PC bore. Place a new O-ring (C138A) onto the PC adjusting screw and thread it into the PC bore until flush, then make another full turn. Install and torque the PC set screw (C102) to 9 N•m [7 lbf•ft].

For PC only controls, skip steps 3 through 5.

3. Install the LS spool (C112), spherical end first, into the LS bore. Using a new O-ring (C105A or C106A), install the plug (C105 or C106). Torque the plug (C105 or C106) to 12 N•m [9 lbf•ft].
4. Using a new O-ring (C104A), install the plug (C104). Torque the plug to 12 N•m [9 lbf•ft].
5. Place the two LS springs (C114, C115) onto the spring guide (C113) and install into the LS bore. Place a new O-ring (C118A) and back-up rings (C118B) onto the LS adjusting screw and thread it into the LS bore until flush, then make another full turn. Install and torque the LS set screw (C102) to 9 N•m [7 lbf•ft].
6. Using petroleum jelly to retain them, install 4 new interface O-rings (C200) in the recesses on the control housing.
7. Install the control assembly onto the endcap using the 4 screws (C300). Torque the screws to 6 N•m [5 lbf•ft]. Torque screws in a criss-cross pattern and re-torque the first screw to ensure proper torque retention.
8. Check and adjust the control setting. See *Adjustments* section.

Control assembly

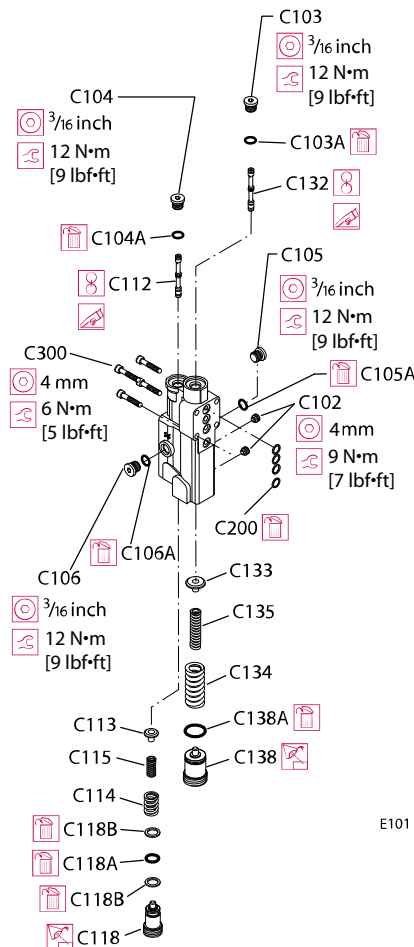

E101 226

LS control shown; parts C104 through C106 and C112 through C118 are not used on PC control

**Minor repair**

**Electric Controls**

**Disassembly**

1. Remove four screws (C300).
2. Remove the control and discard the four O-rings (C200).
3. Remove set screws (C102), PC adjusting plug (C138) with O-ring (C138A), springs (C134, C135), and seat (C133). Discard the O-ring if it is damaged.
4. Remove plug (C103). Remove PC spool (C132). Note orientation of the spool for reassembly.
5. Remove plug (G030), and orifice (G020).
6. Remove LS adjusting plug (C118), springs (C114, C115), and seat (C113).
7. Remove plug (C104), and spool (C112). Note the orientation of the spool for reassembly.
8. Remove four screws (C151). Remove the manifold (C152) and discard the two interface O-rings (C154).
9. For electric proportional controls only: Remove the electric control manifold drain orifice (C149).
10. Remove plug (C153). Remove the cartridge valve nut (C125), electric solenoid (C155), and cartridge valve (C150) from the electric control manifold.

*Control assembly*

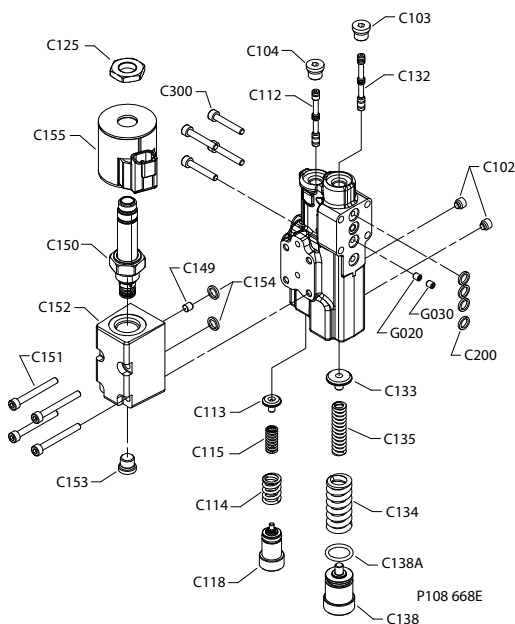

**Inspection**

1. Inspect the adjusting plugs for wear at the tips and where they contact the springs; replace as necessary.
2. Inspect the springs and spring guides for wear or damage; replace as necessary.
3. Carefully inspect the spools. Ensure the sealing lands are free of nicks and scratches. Check the ends that contact the spring guides for wear. Replace spools as necessary.
4. Inspect the control housing for damage. Check the spool bores for excessive wear.
5. Remove debris from orifices if necessary. Ensure the servo control orifice backup plug is clean, and remove debris if necessary.
6. Clean all parts and lubricate spools, springs, guides and new O-rings with clean hydraulic fluid.

## Minor repair

### Reassembly

1. Install the servo control orifice (G020), and torque to 2.7 N·m [24 in·lb]. Then install the orifice backup plug (G030), and torque to 2.7 N·m [24 in·lb].
2. Install the PC spool (C132), spherical end first, into the PC bore. Install plug (C103). Torque the plug to 12 N·m [8.9 lbf·ft].
3. Place the two PC springs (C134, C135) onto the spring guide (C133) and install into the PC bore. Place a new O-ring (C138A) onto the PC adjusting screw (C138) and thread it into the PC bore until flush, then make another full turn. Install and torque the PC set screw (C102) to 9.6 N·m [7.1 lbf·ft].
4. Install the LS spool (C112), spherical end first, into the LS bore.
5. Install plug (C104). Torque the plug to 12 N·m [8.9 lbf·ft].
6. Place the two LS springs (C114, C115) onto the spring guide (C113) and install into the LS bore. Thread adjusting screw (C118) into the LS bore until flush, then make another full turn. Install and torque the LS set screw (C102) to 9.6 N·m [7.1 lbf·ft].
7. Install the electric control manifold drain orifice (C149) and torque to 2.7 N·m [24 in·lb].
8. Install the cartridge valve (C150) into the electric control manifold (C152). Torque to 27.7 N·m [20.4 lbf·ft]. DO NOT OVERTORQUE the cartridge valve.
9. Install the electric solenoid (C155), and solenoid coil nut (C125). Torque to 8.7 N·m [6.4 lbf·ft].
10. Install plug (C153). Torque the plug to 12 N·m [8.9 lbf·ft].
11. Using petroleum jelly to retain them, install the two interface O-rings (C154) in the recesses on the electric control manifold.
12. Install the manifold assembly onto the control housing using four screws (C151). Torque the screws to 6.4 N·m [4.7 lbf·ft]. Torque the screws in a criss-cross pattern and re-torque the first screw to ensure proper torque retention.
13. Using petroleum jelly to retain them, install the four interface O-rings (C200) in the recesses on the control housing.
14. Install the control assembly onto the endcap using the four screws (C300). Torque the screws to 6.4 N·m [4.7 lbf·ft]. Torque screws in a criss-cross pattern and re-torque the first screw to ensure proper torque retention.
15. Check and adjust the control setting. See *Adjustments* section.

## Electronic Torque Limiting Control

### Repair

Disassembly, inspection and reassembly steps are the same as the steps in the previous topic (Electric Controls). This includes repair of the spools and plugs.

---

The solenoid (C155), nut (QC125), and O-rings (QC120) for the valve are available as separate repair parts. The valve is only available as a complete assembly (QC150).

---

If it is necessary to remove the orifice (H020), use a 3 mm internal hex wrench. Torque it to 2.7 Nm [24 in·lb] when it is installed in the manifold.

---

Minor repair

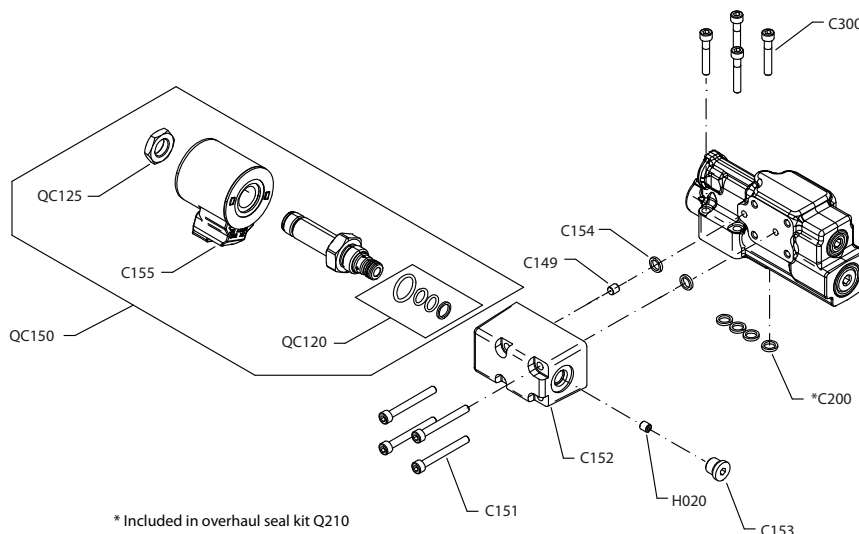

P108790

Item	Description	Wrench size	Torque
C149	Orifice	3 mm internal hex	2.7 Nm [24 in-lb]
C151	Screws		6.4 Nm [4.7 lbf-ft]
C152	Manifold	-	-
C153	Plug	5 mm internal hex	12 Nm [8.9 lbf-ft]
C154	O-ring	-	-
C155	Solenoid	-	-
C200	O-rings	-	-
C300	Screws		6.4 Nm [4.7 lbf-ft]
QC120	O-rings		
QC125	Nut		8.7 Nm [6.4 lbf-ft]
QC150	Valve assembly		27.7 Nm [20.4 lbf-ft]
H020	Manifold orifice	3 mm internal hex	2.7 Nm [24 in-lb]

Fan Drive Control

Disassembly

Use the wrench sizes and torques listed in the table.

1. Remove four screws (C300).
2. Remove the control and discard the 4 interface O-rings (C200).
3. Remove the coil plastic nut (QC125) Remove the coil.

Remember the correct coil connector orientation.

4. Remove the solenoid cartridge (C120). Remove O-ring (QC120).
5. Remove spring (C124) and spring guide (C123).
6. Remove the pressure limiter adjuster (C128).
7. Remove spring (C125) and spool (C122).
8. Remove plug (C107) and plug (C129).

Minor repair

9. Remove gain orifice (H030).
10. Remove servo control orifice (G020).

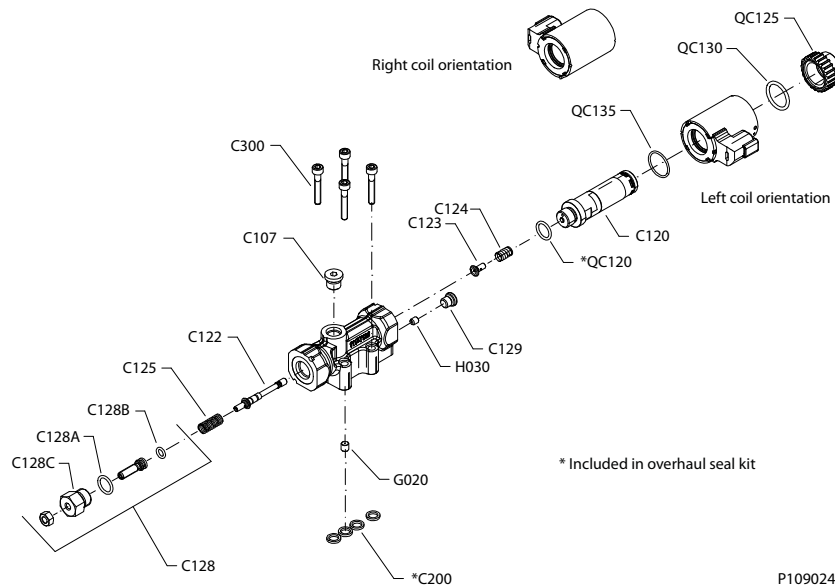

P109024

Item	Description	Wrench size	Torque
G020	Servo control orifice	3 mm internal hex	2.7 N•m [2 lbf•ft]
H030	Gain orifice	2,5 mm internal hex	2.7 N•m [2 lbf•ft]
C129	Plug 5/16"	1/8" internal hex	6.2 N•m [4.67 lbf•ft]
C107	Plug 7/16"	3/16" internal hex	13.7 N•m [9.9 lbf•ft]
C128C	Nut 9/16"	17 mm exter hex	23.7 N•m [17.5 lbf•ft]
C120	Solenoid cartridge	17 mm exter hex	25.75 N•m [19 lbf•ft]
QC125	Coil plastic nut	26 mm 12 pt socket	3.5 N•m [2 lbf•ft]
C300	Screws	4 mm internal hex	6.5 N•m [4.75 lbf•ft]

Inspection

1. Inspect the pressure limiter for wear. Check for contamination and damage to the O-rings, replace if necessary.
2. Inspect the control housing for damage. Check the spool bores for excessive wear. Remove debris from orifices if necessary.
3. Carefully inspect the spool. Ensure the sealing lands are free of nicks, burrs and scratches. Check the ends that contact the spring guides for wear. Replace the spool if necessary.
4. Check the spool for free (smooth) movement in housing bore.
5. Check the orifices (H030 and G020) for contamination, and for cavitation damage.
6. Check the solenoid cartridge for damage, bending, free pin movement.
7. Check the coil for damage. Check the plastic plug for contamination.
8. Check the coil connector for contamination or overheat marks, deformation, connector pins are not damaged or bent, or missing. Replace the coil if necessary.
9. Check the control o-rings for damage, or cracks and replace if necessary.
10. Clean and lubricate all spools, bores, and seals with a light coating of hydraulic oil.

**Minor repair**

**Reassembly**

1. Install the servo control orifice (G020). Install the gain orifice (H030).
2. Install plugs (C129) and (C107).
3. Install spool (C122) spherical end first, into the spool bore. Install spring (C125).
4. Install the pressure limiter adjuster (C128).
5. Install the spring guide (C123) and spring (C124). Ensure the spring guide is properly seated on the spools spherical head.
6. Install the solenoid cartridge with its O-ring.
7. Install the coil and O-rings. Ensure that the O-rings are correctly installed. Ensure the coil connector is in **right** orientation.
8. Install the coil plastic nut (QC125).

Use the proper wrench, do not damage the plastic nut.

9. Using petroleum jelly to retain them, install the four interface O-rings (C200) in the recesses on the control housing.
10. Install the control assembly onto the endcap using four screws (C300). Torque screws in a criss-cross pattern and re-torque the first screw to ensure proper torque retention.

**Angle Sensor**

**Removal**

1. Remove the 4 sensor housing screws (K190), sensor housing, and sensor housing O-ring (K175).
2. Remove 2 locating dowels (K180).
3. Remove 2 magnet carrier screws (K110) and discard. Remove magnet carrier (K100) from swashplate through housing.

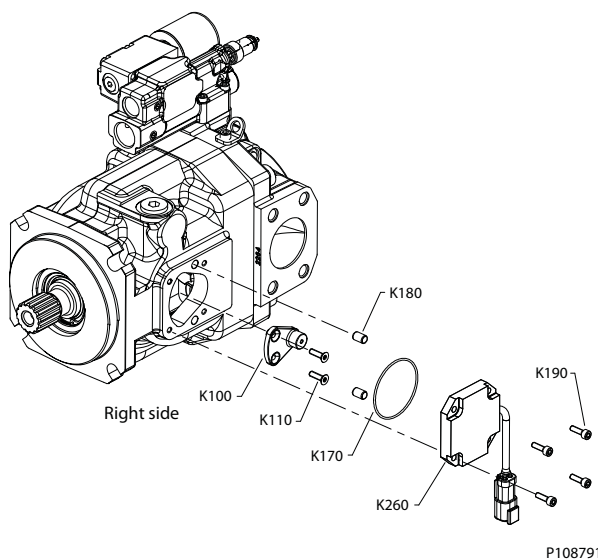

Item	Description	Wrench size	Torque
K100	Magnet carrier		-
K110	Carrier screws	-	4.5 Nm [3.35 lbf ft]
K170	O-ring	-	-

**Minor repair**

Item	Description	Wrench size	Torque
K180	Locating dowels	-	-
K190	Screws		5.9 Nm [4.35 lbf ft]
K260	Housing	-	-

**Inspection**

1. Carefully examine the angle sensor kit (K260) for mechanical damages ,cracks, or scratched surfaces.
2. Check the angle sensor connector for breaks, pin deformation, or contamination.
3. Check sensor wiring for heat damage, scuffing/chafing, or kinks.
4. Check sensor seal area for contamination and surface damage
5. Check magnet carrier (K100) for cracks , deformations, wearing, and for contamination with magnetic particles

**⚠ Warning**

A thorough inspection with the angle sensor removed is a strong indicator of pump and hydraulic system contamination and filtration quality.

**Installation**

1. Using new magnet carrier screws with locking compound (K110) install the magnet carrier (K100) to pump swashplate through the housing. Torque the screws to 4.5 Nm [3.3 lbf-ft].

**⚠ Warning**

Used magnet carrier screws may loosen and lead to premature failure. Ensure that new screws with locking compound are utilized.

2. Install the locating dowels (K180) into the dowel holes.
3. Lubricate new O-ring (K170) with petroleum jelly. Install the O-ring to the angle sensor housing (K260) first.
4. Install angle sensor housing with O-ring to housing with 4 screws (K190) and torque to 5.9 Nm [4.4 lbf-ft].

**Servo Control Orifice**

**Disassembly**

1. Remove four screws (C300).
2. Remove the control and discard the four O-rings (C200).
3. Remove PC plug (C103), and PC spool (C132) from the control housing.

Note the orientation of the spool for reassembly.

**Minor repair**

4. Remove backup plug (G030), and orifice (G020).

*Control assembly*

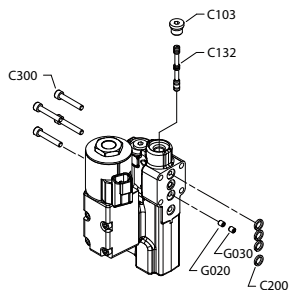

P108 669E

**Reassembly**

1. Install the orifice (G020), and torque to 2-3.4 N•m [18-30 in•lb]. Then install the orifice backup plug (G030), and torque to 2-3.4 N•m [18-30 in•lb].
2. Install the PC spool (C132), spherical end first, into the PC bore. Install plug (C103). Torque the plug to 10.8 - 13.5 N•m [8 - 10 lbf•ft].
3. Using petroleum jelly to retain them, install the four O-rings (C200) in the recesses on the control housing.
4. Install the control assembly onto the endcap using four screws (C300). Torque the screws to 5.4 - 7.5 N•m [4 - 5.5 lbf•ft]. Torque screws in a criss-cross pattern and re-torque the first screw to ensure proper torque retention.

**Plug and fitting sizes and torques**

If any plugs or fittings are removed from the unit during service, install and torque as indicated here. This drawing is a composite. Individual pump configurations may be different. The illustration below shows the appropriate wrench size and torque for plugs that may be installed in the pump:

**Minor repair**

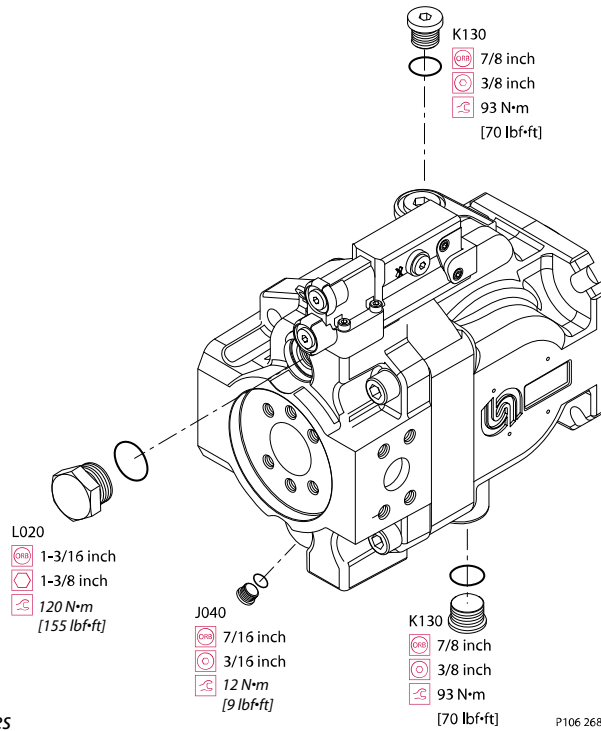

*Plug locations, sizes, and torques*



#### Products we offer:

- Bent Axis Motors
- Closed Circuit Axial Piston Pumps and Motors
- Displays
- Electrohydraulic Power Steering
- Electrohydraulics
- Hydraulic Power Steering
- Integrated Systems
- Joysticks and Control Handles
- Microcontrollers and Software
- Open Circuit Axial Piston Pumps
- Orbital Motors
- PLUS+1® GUIDE
- Proportional Valves
- Sensors
- Steering
- Transit Mixer Drives

**Danfoss Power Solutions** is a global manufacturer and supplier of high-quality hydraulic and electronic components. We specialize in providing state-of-the-art technology and solutions that excel in the harsh operating conditions of the mobile off-highway market. Building on our extensive applications expertise, we work closely with our customers to ensure exceptional performance for a broad range of off-highway vehicles.

We help OEMs around the world speed up system development, reduce costs and bring vehicles to market faster.

Danfoss – Your Strongest Partner in Mobile Hydraulics.

**Go to [www.powersolutions.danfoss.com](http://www.powersolutions.danfoss.com) for further product information.**

Wherever off-highway vehicles are at work, so is Danfoss. We offer expert worldwide support for our customers, ensuring the best possible solutions for outstanding performance. And with an extensive network of Global Service Partners, we also provide comprehensive global service for all of our components.

Please contact the Danfoss Power Solution representative nearest you.

#### Comatrol

[www.comatrol.com](http://www.comatrol.com)

#### Schwarzmueller-Inverter

[www.schwarzmueller-inverter.com](http://www.schwarzmueller-inverter.com)

#### Turolla

[www.turollaocg.com](http://www.turollaocg.com)

#### Hydro-Gear

[www.hydro-gear.com](http://www.hydro-gear.com)

#### Daikin-Sauer-Danfoss

[www.daikin-sauer-danfoss.com](http://www.daikin-sauer-danfoss.com)

Local address:

**Danfoss Power Solutions (US) Company**  
2800 East 13th Street  
Ames, IA 50010, USA  
Phone: +1 515 239 6000

**Danfoss Power Solutions GmbH & Co. OHG**  
Krokamp 35  
D-24539 Neumünster, Germany  
Phone: +49 4321 871 0

**Danfoss Power Solutions ApS**  
Nordborgvej 81  
DK-6430 Nordborg, Denmark  
Phone: +45 7488 2222

**Danfoss Power Solutions Trading (Shanghai) Co., Ltd.**  
Building #22, No. 1000 Jin Hai Rd  
Jin Qiao, Pudong New District  
Shanghai, China 201206  
Phone: +86 21 3418 5200

Danfoss can accept no responsibility for possible errors in catalogues, brochures and other printed material. Danfoss reserves the right to alter its products without notice. This also applies to products already on order provided that such alterations can be made without changes being necessary in specifications already agreed. All trademarks in this material are property of the respective companies. Danfoss and the Danfoss logotype are trademarks of Danfoss A/S. All rights reserved.