



Technical Information
**Orbital Motors
with Speed Sensor**



Revision history*Table of revisions*

Date	Changed	Rev
June 2015	Code numbers deleted under OMS EM	0201
November 2014	Converted to Danfoss layout - DITA CMS	CA
November 2012	First edition	BF

Contents
A wide range of Orbital Motors

A Wide Range of Hydraulic Motors.....	5
Survey of Literature with Technical Data on Danfoss Hydraulic Motors.....	6

Data survey

Introduction.....	7
Principle.....	7
Advantages.....	7
Typical Applications.....	7

Versions OMM EM, OMP EM and OMR EM

Versions.....	8
Features available:.....	8

Code Numbers OMM EM, OMP EM and OMR EM

Code Numbers.....	9
Ordering.....	9

Versions OMS EM, OMT EM and OMV EM

Versions.....	10
Features available:.....	10

Code Numbers OMS EM, OMT EM and OMV EM

Code number.....	11
Ordering.....	11

Technical Data OMM EM

Technical data for OMM EM.....	12
Max. Permissible Shaft Seal Pressure.....	13
OMM EM with check valves and without use of drain connection:.....	13
OMM EM with check valves and drain connection:.....	13
Pressure Drop in Motor.....	13

Technical Data OMP EM

Technical Data for OMP EM.....	14
OMP EM with Standard Shaft Seal.....	15
OMP EM with standard shaft seal, check valves and without use of drain connection:.....	15
OMP EM with standard shaft seal, check valves and with drain connection:.....	15
Pressure Drop in Motor.....	16

Technical Data OMR EM

Technical data for OMR EM.....	17
OMR EM with Standard Shaft Seal.....	18
OMR EM with standard shaft seal, check valves and without use of drain connection:.....	18
OMR EM with standard shaft seal, check valves and with drain connection:.....	18
Pressure Drop in Motor.....	19

Technical Data OMS EM and OMSW EM

Technical data for OMS EM and OMSW EM.....	20
--	----

Technical Data OMS EM

Max. Permissible Shaft Seal Pressure.....	21
OMS EM with standard shaft seal, check valves and without use of drain connection:.....	21
OMS EM with standard shaft seal, check valves and with drain connection:.....	21
Pressure Drop in Motor.....	22

Technical Data OMT EM

Technical data for OMT EM.....	23
Max. Permissible Shaft Seal Pressure.....	24
OMT EM with check valves and without use of drain connection:.....	24
OMT EM with check valves and with drain connection:.....	24
Pressure Drop in Motor.....	25

Technical Data OMV EM

Technical data for OMV EM.....	26
--------------------------------	----

Contents

Max. Permissible Shaft Seal Pressure.....	27
OMV EM with check valves and without use of drain connection:.....	27
OMV EM with check valves and with drain connection:.....	27
Pressure drop in motor.....	27

Technical Data Speed Sensor

Technical Data Speed Sensor.....	28
Mechanical data:.....	28
Electrical data.....	28
Wiring Diagram.....	29
Speed Sensor with Plug Connection Dimensions.....	29
Speed Sensor with Molded in Cable Dimensions.....	30
Spare Parts.....	30
Speed sensor.....	30
Accessories.....	30
Cable with plug.....	30
Wire (shield).....	31
Plug.....	31

Shaft Versions

Shaft Versions.....	32
---------------------	----

Port Thread Versions

Port Thread Versions.....	35
---------------------------	----

Dimensions - European Version

OMM EM Side Port Version.....	38
OMM EM End Port Version.....	40
OMP EM Side Port Version with 2 Hole Oval Mounting Flange (A2-flange) with Drain Connection.....	41

Dimensions - US Version

OMP EM Side Port Version with 2 Hole Oval Mounting Flange (A2-flange) with Drain Connection.....	43
--	----

Dimensions - European Version

OMR EM Side Port Version with 2 Hole Oval Mounting Flange (A2-flange) with Drain Connection.....	45
--	----

Dimensions - US Version

OMR EM Side Port Version with 2 Hole Oval Mounting Flange (A2-flange) with Drain Connection.....	47
--	----

Dimensions - European Version

OMS EM.....	49
-------------	----

Dimensions - US Version

OMS EM.....	51
OMSW EM.....	53

Dimensions - European Version

OMT EM.....	55
-------------	----

Dimensions - US Version

OMT EM.....	57
-------------	----

Dimensions - European Version

OMV EM.....	59
-------------	----

Weight of Motors

Weight of Motors OMM,OMP and OMR.....	61
Weight of Motors OMS, OMT and OMV.....	62

A wide range of Orbital Motors

A Wide Range of Hydraulic Motors

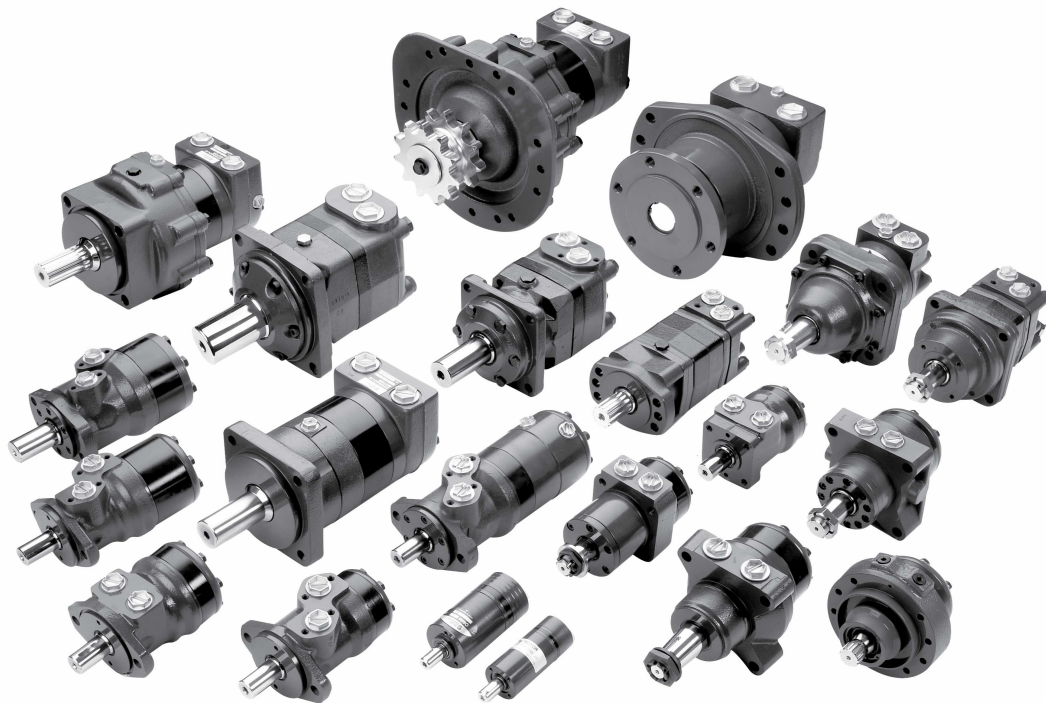

Danfoss is a world leader within production of low speed hydraulic motors with high torque. We can offer more than 3000 different hydraulic motors, categorised in types, variants and sizes (incl. different shaft versions).

The motors vary in size (rated displacement) from 8 cm³ [0.50 in³] to 800 cm³ [48.9 in³] per revolution.

Speeds range up to approx. 2500 min⁻¹ (rpm) for the smallest type and up to approx 600 min⁻¹ (rpm) for the largest type.

Maximum operating torques vary from 13 Nm [115 lbf-in] to 2700 Nm [24.000 lbf-in] (peak) and maximum outputs are from 2.0 kW [2.7 hp] to 70 kW [95 hp].

Characteristic features:

- Smooth running over the entire speed range
- Constant operating torque over a wide speed range
- High starting torque
- High return pressure without the use of drain line (High pressure shaft seal)
- High efficiency
- Long life under extreme operating conditions
- Robust and compact design
- High radial and axial bearing capacity
- For applications in both open and closed loop hydraulic systems
- Suitable for a wide variety of hydraulics fluids

The programme is characterised by technical features appealing to a large number of applications and a part of the programme is characterised by motors that can be adapted to a given application. Adaptions comprise the following variants among others:

A wide range of Orbital Motors

- Motors with corrosion resistant parts
- Wheel motors with recessed mounting flange
- OMP, OMR- motors with needle bearing
- OMR motor in low leakage version
- OMR motors in a super low leakage version
- Short motors without bearings
- Ultra short motors
- Motors with integrated positive holding brake
- Motors with integrated negative holding brake
- Motors with integrated flushing valve
- Motors with speed sensor
- Motors with tacho connection
- All motors are available with black finish paint

The Danfoss LSHT motors are used in the following application areas:

- Construction equipment
- Agricultural equipment
- Material handling & Lifting equipment
- Forestry equipment
- Lawn and turf equipment
- Special purpose
- Machine tools and stationary equipment
- Marine equipment

Survey of Literature with Technical Data on Danfoss Hydraulic Motors

Detailed data on all Danfoss motors can be found in our motor catalogue, which is divided into 8 individual subcatalogues:

- General information on Danfoss hydraulic motors: function, use, selection of hydraulic motor, hydraulic systems, etc.
- Technical data on small motors: OML and OMM
- Technical data on medium sized motors: OMP, OMR and OMH
- Technical data on medium sized motors: DH and DS
- Technical data on medium sized motors: OMEW
- Technical data on large motors: OMS, OMT and OMV
- Technical data on large motors: TMK
- Technical data on large motors: TMT
- Technical data on large motors: TMVW

A general survey brochure on Danfoss hydraulic motors gives a quick motor reference based on power, torque, speed and capabilities.

Data survey

Introduction

Danfoss has developed a speed sensor specially designed for LSHT motors.

The electric output signal is a standard voltage signal that can be used for regulating the speed motor.

Principle

The speed is measured by a sensor in accordance with the Hall principle. Signal processing and amplification are performed in the sensor housing. A connection is provided in the housing for a Binder Series 713 plug or a plug with 5 metres of cable (available from Danfoss). The sensor can also be supplied with 2 metres molded in cable.

Advantages

- Robust design
- CE-marked
- Fulfils EMC requirements of EN50081 and EN50082
- Large frequency range, precise regulation
- No limit on motor performance when compared to corresponding motors without speed sensor (except OMM EM)
- IEC 529 degree of protection: IP 67
- Replacable transducer
- Standard speed signal
- Easy installation
- Electronic signal processing and amplification integrated in the sensor's housing and requiring no maintenance.

Typical Applications

- Speed indication
- Setting tightening speed in machine tools
- Extend/retract positioning of work platforms
- Granulate metering on injection moulding machines
- Conveyor speed regulation
- Metering on salt spreaders

Technical Information Orbital Motors with Speed Sensor

Versions OMM EM, OMP EM and OMR EM

Versions

Mounting flange	Spigot diameter	Bolt circle diameter (BC)	Shaft	Port size	European version-delivered with sensor for plug connector (PNP version)	US version - delivered with sensor with 2 m moduled in (PNP version)	Side port version	End port version	Standard shaft seal	Drain connection	Check valve	Main type designation
OMM EM Motors												
Front 4 • M5	Ø60 mm	Ø 45 mm	Cyl. 16 mm	G 3/8	X			X	X	Yes	Yes	OMM EM
				G 3/8	X		X	X	Yes	Yes	OMM EM	
OMP EM Motors												
2 hole oval flange (A2-flange)	Ø 82.5 mm	Ø 106.4 mm	Cyl. 25 mm	G 1/2	X		X		X	Yes	No	OMP EM
	[3.25 in]	[4.19 in]	Cyl. 1 in	7/8 - 14 UN		X	X		X	Yes	No	OMP EM
OMR EM Motors												
2 hole oval flange (A2-flange)	Ø 82.5 mm	Ø 106.4 mm	Cyl. 25 mm	G 1/2	X		X		X	Yes	Yes	OMR EM
	[3.25 in]	[4.19 in]	Cyl. 1 in	7/8 - 14 UN		X	X		X	Yes	Yes	OMR EM

Features available:

Motors in european version: Speed sensor for plug connection.

Motors in US versions: Speed sensor with 2 metres of molded in cable.

Speed sensor for plug connector in NPN version.

[The standard speed sensor is a PNP version](#)

Technical Information Orbital Motors with Speed Sensor

Code Numbers OMM EM, OMP EM and OMR EM
Code Numbers

Code numbers	Displacements														
	8	12.5	20	32	40	50	80	100	125	160	200	250	315	375	400
OMM EM Motors															
151G	5040	5041	5042	5043	-	5044	-	-	-	-	-	-	-	-	-
151G	5045	5046	5047	5048	-	5049	-	-	-	-	-	-	-	-	-
OMP EM Motors															
151-	-	-	-	6874	5390	5391	5392	5393	-	5395	5396	5397	5398	-	5399
151-	-	-	-	-	-	6878	6879	6873	-	6880	6881	6882	6883	-	6884
OMR EM Motors															
151-	-	-	-	-	-	6391	6392	6393	6394	6395	6396	6397	6398	6399	-
151-	-	-	-	-	-	6885	6886	6887	6888	6889	6896	6890	6891	6892	-

Ordering

Add the four digit prefix "151-" to the four digit numbers from the chart for complete code number.

Example:

151-5396 for an OMP 200 with A2 flange, 25 mm shaft, port size G 1/2.

Orders will not be accepted without the four digit prefix.

Technical Information Orbital Motors with Speed Sensor

Versions OMS EM, OMT EM and OMV EM

Versions

Mounting flange	Spigot diameter	Bolt circle diameter (BC)	Shaft	Port size	European version - delivered with sensor for plug connector (PNP version)	US version - delivered with sensor with 2 m moduled in cable (PNP version)	Side port version	Standard shaft seal	Drain connection	Check valve	Main type designation
OMS EM Motors											
Standard flange	Ø82.5 mm	Ø 106.4 mm	Cyl. 32 mm	G 1/2	X		X	X	Yes	Yes	OMS EM
A2-flange	Ø3.25 in	Ø4.19 in	Cyl. 1.25 in	7/8 - 14 UNF		X	X	X	Yes	Yes	OMS EM
Wheel	Ø5 in	Ø6.38 in	Tap. 1.25 in	7/8 - 14 UNF		X	X	X	Yes	Yes	OMSW EM
OMT EM Motors											
Standard flange	Ø125 mm	Ø160 mm	Cyl. 40 mm	G 3/4	X		X	X	Yes	Yes	OMT EM
	Ø5 in	Ø6.38	Cyl. 1.5 in	11/16 - 12 UN			X	X	Yes	Yes	OMT EM
OMV EM Motors											
Standard flange	Ø160 mm	Ø200 mm	Cyl. 50 mm	G 1	X		X	X	Yes	Yes	OMV EM

Features available:

Motors in european version: Speed sensor with 2 metres of molded in cable.

Motors in US versions: Speed sensor for plug connection.

Speed sensor for plug connector in NPN version.

[The standard speed sensor is a PNP version](#)

Technical Information Orbital Motors with Speed Sensor

Code Numbers OMS EM, OMT EM and OMV EM
Code number

Code numbers	Displacements										
	80	100	125	160	200	250	315	400	500	630	800
OMS EM Motors											
151F	3020	3021	3022	3023	3024	3025	3026	3027	-	-	-
151F	3051	3052	3053	3054	3055	3056	3057	3058	3059	-	-
151F	-	3065	3066	-	-	-	3070	3071	-	-	-
OMT EM Motors											
151B	-	-	-	3260	3261	3262	3263	3264	3265	-	-
151B	-	-	-	3700	3701	3702	3703	3704	3705	-	-
OMV EM Motors											
151B	-	-	-	-	-	-	3266	3267	3268	3269	3270

Ordering

Add the four digit prefix "151-" to the four digit numbers from the chart for complete code number.

Example:

151-3702 for an OMP 200 with A2 flange, cyl. 1.5 in shaft, port size 1 1/16 - 12 UN.

Orders will not be accepted without the four digit prefix.

Technical Data OMM EM
Technical data for OMM EM

Type Motor size			OMM EM 8	OMM EM 12.5	OMM EM 20	OMM EM 32	OMM EM 50
Geometric displacements	cm ³ [in ³]		8.2 [19.19]	12.9 [0.79]	19.9 [1.22]	31.6 [1.93]	50.3 [3.08]
Max. speed	min ⁻¹ rpm	cont.	1950	1550	1000	630	400
		int.	2450	1940	1250	800	500
Max torque	Nm [lbf·in]	cont.	11 [95]	16 [140]	25 [220]	40 [350]	46 [410]
		int.	15 [135]	23 [200]	35 [310]	57 [500]	88 [780]
		peak ²⁾	21 [185]	33 [290]	51 [450]	64 [570]	100 [890]
Max. output	kW [hp]	cont.	1.8 [2.4]	2.4 [3.2]	2.4 [3.2]	2.4 [3.2]	1.8 [2.4]
		int. ¹⁾	2.6 [3.5]	3.2 [4.3]	3.2 [4.3]	3.2 [4.3]	3.2 [4.3]
Max. pressure drop	bar [psi]	cont.	100 [1450]	100 [1450]	100 [1450]	100 [1450]	70 [1020]
		int. ¹⁾	140 [2030]	140 [2030]	140 [2030]	140 [2030]	140 [2030]
		peak ²⁾	200 [2900]	200 [2900]	200 [2900]	160 [2320]	160 [2320]
Max. oil flow	l/min [US gal/min]	cont.	16 [4.2]	20 [5.3]	20 [5.3]	20 [5.3]	20 [5.3]
		int. ¹⁾	20 [5.3]	25 [6.6]	25 [6.6]	25 [6.6]	25 [6.6]
Maximum starting pressure with unloaded shaft	bar [psi]		4 [60]	4 [60]	4 [60]	4 [60]	4 [60]
Minimum starting torque	Nm [lbf·in]	at max. press. drop cont.	7 [60]	12 [105]	21 [185]	34 [300]	41 [365]
		at max. press. drop int. ¹⁾	10 [90]	17 [150]	29 [255]	48 [425]	79 [700]
Frequency	[Hz]	max.	1071	1020	816	646	510
Permissible shaft load			Permissible radial shaft load must be reduced by 30% compared to motors without speed sensor. For max. radial loads see catalogue 520L0346				

²⁾ Peak load: the permissible values may occur for max. 1% of every minute.

¹⁾ Intermittent operation: the permissible values may occur for max. 10% of every minute.

Type		Max. inlet pressure
OMM EM 8 - 50	bar [psi] cont.	140 [2030]
	bar [psi] int. ¹⁾	175 [2540]
	bar [psi] peak ²⁾	225 [3260]

¹⁾ Intermittent operation: the permissible values may occur for max. 10% of every minute.

²⁾ Peak load: the permissible values may occur for max. 1% of every minute.

[For further technical specifications please see technical information for OML and OMM \(520L0346\)](#)

Technical Data OMM EM

Max. Permissible Shaft Seal Pressure

OMM EM with check valves and without use of drain connection:

The pressure on the shaft seal never exceeds the pressure in the return line.

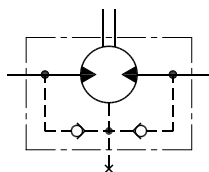

151-320.10

OMM EM with check valves and drain connection:

The shaft seal pressure equals the pressure on the drain line

Max. return pressure without drain line or max. pressure in drain line

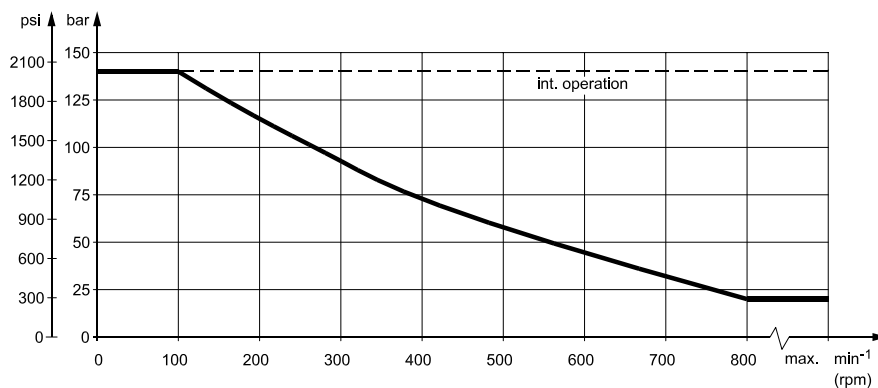

151-1671.10

Pressure Drop in Motor

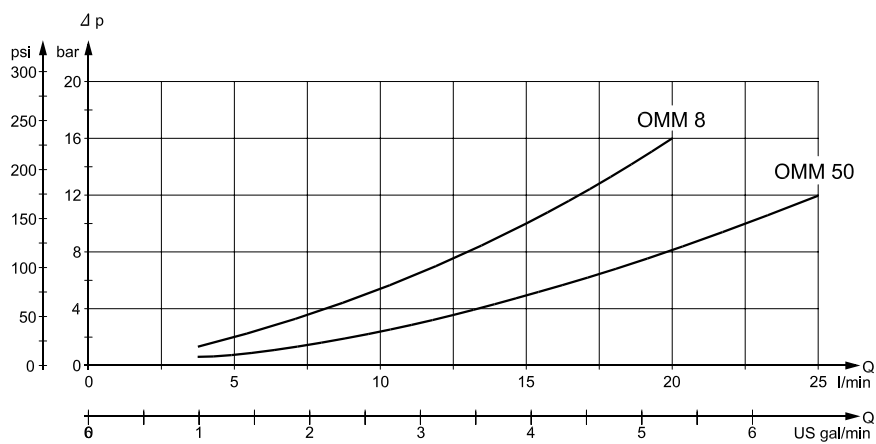

151-1367.10

The curve applies to an unloaded motor shaft and an oil viscosity of 35 mm²/s (165 SUS)

Technical Information Orbital Motors with Speed Sensor

Technical Data OMP EM

Technical Data for OMP EM

Type Motor size			OMP EM 40	OMP EM 50	OMP EM 80	OMP EM 100	OMP EM 160	OMP EM 200	OMP EM 250	OMP EM 315	OMP EM 400
Geometric displacements	cm ³ [in ³]		40 [2.45]	48.6 [2.97]	77.8 [4.76]	97.3 [5.95]	155.7 [9.53]	194.6 [11.91]	242.3 [14.83]	306.1 [18.73]	389.2 [23.82]
Max. speed	min ⁻¹ rpm	cont.	1500	1230	770	615	385	310	250	195	155
		int.	1750	1540	960	770	480	385	310	245	190
Max torque	Nm [lbf·in]	cont.	52 [460]	93 [820]	150 [1330]	190 [1680]	300 [2660]	300 [2660]	300 [2660]	300 [2660]	300 [2660]
		int.	74 [669]	120 [1060]	190 [1680]	230 [2040]	370 [3280]	380 [3360]	410 [3630]	390 [3450]	420 [3720]
		peak ²⁾	107 [950]	140 [1240]	220 [1950]	270 [2390]	430 [3810]	540 [4780]	550 [4870]	600 [5310]	600 [5310]
Max. output	kW [hp]	cont.	7.0 [9.4]	10.0 [13.4]	10.0 [13.4]	11.0 [14.8]	10.0 [13.4]	8.0 [10.7]	6.0 [8.1]	5.0 [6.7]	4.0 [5.4]
		int. ¹⁾	10.6 [14.2]	12.0 [16.1]	12.0 [16.1]	13.0 [17.4]	12.0 [16.1]	11.0 [14.8]	9.0 [12.1]	7.0 [9.4]	6.0 [8.1]
Max. pressure drop	bar [psi]	cont.	100 [1450]	140 [2030]	140 [2030]	140 [2030]	140 [2030]	115 [1670]	90 [1310]	75 [1090]	60 [870]
		int. ¹⁾	140 [2030]	175 [2540]	175 [2540]	175 [2540]	175 [2540]	150 [2180]	125 [1810]	100 [1410]	80 [1160]
		peak ²⁾	225 [3260]	225 [3260]	225 [3260]	225 [3260]	225 [3260]	225 [3260]	180 [2610]	160 [2320]	130 [1890]
Max. oil flow	l/min [US gal/min]	cont.	60 [15.9]	60 [15.9]	60 [15.9]	60 [15.9]	60 [15.9]	60 [15.9]	60 [15.9]	60 [15.9]	60 [15.9]
		int. ¹⁾	70 [18.5]	75 [19.8]	75 [19.8]	75 [19.8]	75 [19.8]	75 [19.8]	75 [19.8]	75 [19.8]	75 [19.8]
Max. starting pressure with unloaded shaft	bar [psi]		10 [145]	10 [145]	10 [145]	10 [145]	7 [100]	5 [75]	5 [75]	5 [75]	5 [75]
Min starting torque	Nm [lbf·in]	at max. press. drop cont.	45 [400]	80 [710]	135 [1200]	170 [1510]	280 [2480]	270 [2390]	280 [2480]	280 [2480]	280 [2480]
		at max. press. drop int. ¹⁾	63 [560]	100 [890]	170 [1510]	210 [1860]	350 [3100]	360 [3190]	390 [3450]	370 [3280]	400 [3540]
Frequency	[Hz]	max.	1021	898	560	449	280	225	181	143	111

²⁾ Peak load: the permissible values may occur for max. 1% of every minute.

¹⁾ Intermittent operation: the permissible values may occur for max. 10% of every minute.

Type		Max. inlet pressure	Max. return pressure with drain line
OMP EM 25 - 400	bar [psi] cont.	175 [2040]	175 [2040]
	bar [psi] int. ¹⁾	200 [2900]	200 [2900]
	bar [psi] peak ²⁾	225 [3260]	225 [3260]

¹⁾ Intermittent operation: the permissible values may occur for max. 10% of every minute.

²⁾ Peak load: the permissible values may occur for max. 1% of every minute.

[For further technical specifications please see technical information for OMP, OMR, OMH and OMEW \(520L0262\)](#)

Technical Data OMP EM

OMP EM with Standard Shaft Seal

OMP EM with standard shaft seal, check valves and without use of drain connection:

The pressure on the shaft seal never exceeds the pressure in the return line.

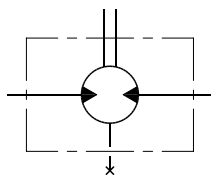

151-1855.10

OMP EM with standard shaft seal, check valves and with drain connection:

The shaft seal pressure equals the pressure on the drain line

Max. return pressure without drain line or max. pressure in drain line

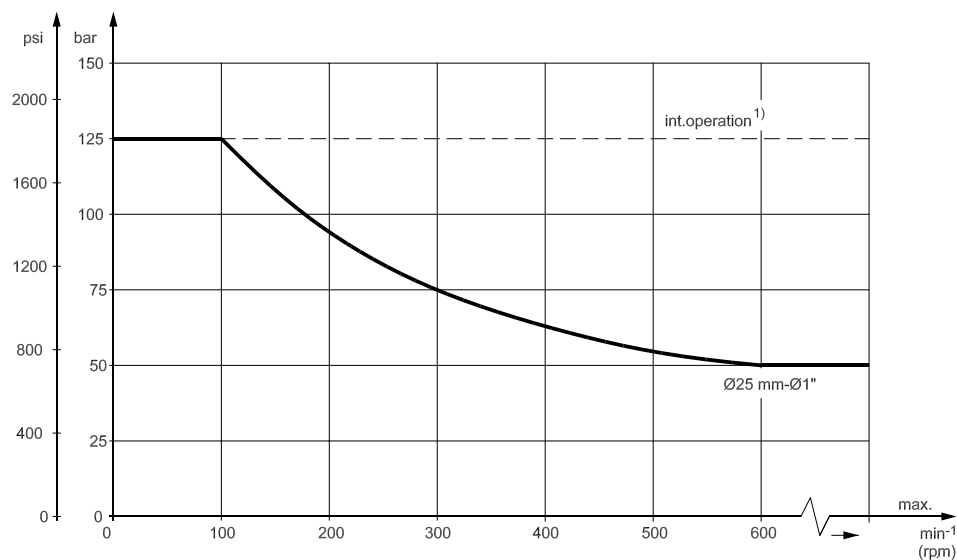

151-2074.10

Technical Information Orbital Motors with Speed Sensor

Technical Data OMP EM

Pressure Drop in Motor

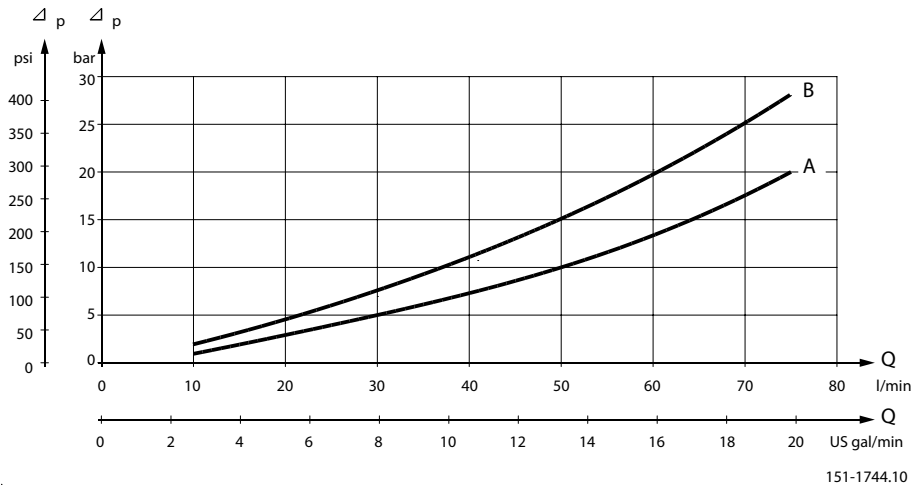

A OMP 50 - 400

B OMP 32 - 40

The curve applies to an unloaded motor shaft and an oil viscosity of 35 mm²/s (165 SUS).

Technical Information Orbital Motors with Speed Sensor

Technical Data OMR EM

Technical data for OMR EM

Type Motor size			OMR EM 50	OMR EM 80	OMR EM 100	OMR EM 125	OMR EM 160	OMR EM 200	OMR EM 250	OMR EM 315	OMR EM 375
Geometric displacements	cm ³ [in ³]		51.6 [3.16]	80.3 [4.91]	99.8 [6.11]	125.7 [7.69]	159.6 [9.77]	199.8 [12.23]	249.3 [15.26]	315.7 [19.32]	372.6 [22.80]
Max. speed	min ⁻¹ rpm	cont.	775	750	600	475	375	300	240	190	160
		int.	970	940	750	600	470	375	300	240	200
Max torque	Nm [lbf·in]	cont.	100 [890]	195 [1730]	240 [2120]	300 [2660]	300 [2660]	300 [2660]	300 [2660]	300 [2660]	300 [2660]
		int.	130 [1150]	220 [1957]	280 [2480]	340 [3010]	390 [3450]	390 [3450]	380 [3360]	420 [3720]	430 [3810]
		peak ²⁾	170 [1510]	270 [2390]	320 [2830]	370 [3280]	460 [4070]	560 [4960]	600 [5310]	610 [5400]	600 [5310]
Max. output	kW [hp]	cont.	7.0 [9.4]	12.5 [16.8]	13.0 [17.4]	12.5 [16.8]	10.0 [13.4]	8.0 [10.7]	6.0 [8.1]	5.0 [6.7]	4.0 [5.4]
		int. ¹⁾	8.5 [11.4]	15.0 [20.1]	15.0 [20.1]	14.5 [19.4]	12.5 [16.8]	10.0 [13.4]	8.0 [10.7]	6.5 [8.7]	6.0 [8.1]
Max. pressure drop	bar [psi]	cont.	140 [2030]	175 [2540]	175 [2540]	175 [2540]	130 [1890]	110 [1600]	80 [1160]	70 [1020]	55 [800]
		int. ¹⁾	175 [2540]	200 [2900]	200 [2900]	200 [2900]	175 [2540]	140 [2030]	110 [1600]	100 [1410]	85 [1230]
		peak ²⁾	225 [3260]	225 [3260]	225 [3260]	225 [3260]	225 [3260]	225 [3260]	200 [2900]	150 [2180]	130 [1890]
Max. oil flow	l/min [US gal/min]	cont.	40 [10.6]	60 [15.9]	60 [15.9]	60 [15.9]	60 [15.9]	60 [15.9]	60 [15.9]	60 [15.9]	60 [15.9]
		int. ¹⁾	50 [13.2]	75 [19.8]	75 [19.8]	75 [19.8]	75 [19.8]	75 [19.8]	75 [19.8]	75 [19.8]	75 [19.8]
Max. starting pressure with unloaded shaft	bar [psi]		10 [145]	10 [145]	10 [145]	9 [130]	7 [100]	5 [75]	5 [75]	5 [75]	5 [75]
Min starting torque	Nm [lbf·in]	at max. press. drop cont.	80 [710]	150 [1330]	200 [1770]	250 [2210]	240 [2120]	260 [2390]	240 [2120]	260 [2300]	240 [2120]
		at max. press. drop int. ¹⁾	100 [890]	170 [1500]	230 [2040]	280 [2480]	320 [2830]	330 [2920]	310 [2740]	350 [3100]	380 [3360]
Frequency	[Hz]	max.	566	548	438	350	274	219	175	140	117

²⁾ Peak load: the permissible values may occur for max. 1% of every minute.

¹⁾ Intermittent operation: the permissible values may occur for max. 10% of every minute.

Type		Max. inlet pressure	Max. return pressure with drain line
OMR EM 50 - 375	bar [psi] cont	175 [2540]	175 [2540]
	bar [psi] int. ¹⁾	200 [2900]	200 [2900]
	bar [psi] peak	225 [3260]	225 [3260]

¹⁾ Intermittent operation: the permissible values may occur for max. 10% of every minute.

For further technical specifications please see technical information for OMP, OMR, OMH and OMEW (520L0262)

Technical Data OMR EM

OMR EM with Standard Shaft Seal

OMR EM with standard shaft seal, check valves and without use of drain connection:

The pressure on the shaft seal never exceeds the pressure in the return line.

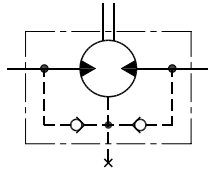

151-320.10

OMR EM with standard shaft seal, check valves and with drain connection:

The shaft seal pressure equals the pressure on the drain line

Max. return pressure without drain line or max. pressure in drain line

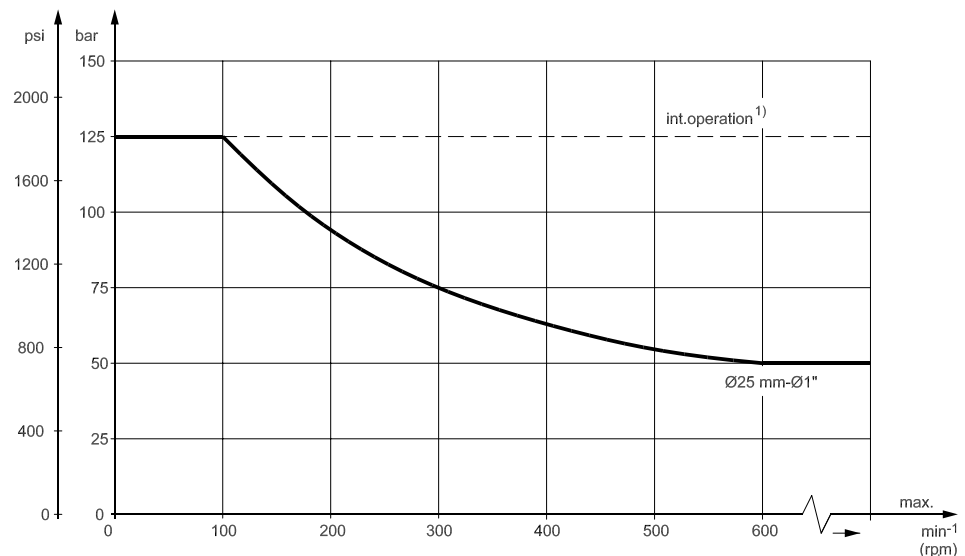

151-2074.10

1) Intermittent operation: the permissible values may occur for max. 10% of every minute.

Technical Data OMR EM

Pressure Drop in Motor

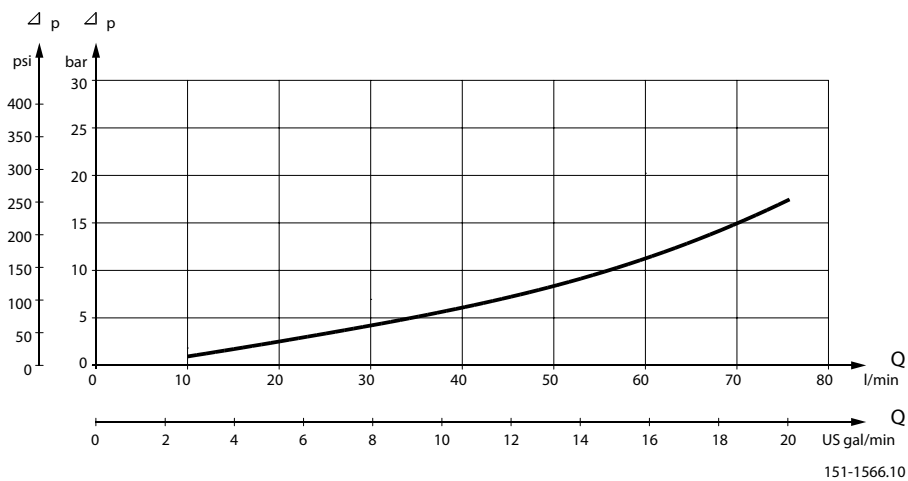

The curve applies to an unloaded motor shaft and an oil viscosity of 35 mm²/s (165 SUS)

Technical Information Orbital Motors with Speed Sensor

Technical Data OMS EM and OMSW EM

Technical data for OMS EM and OMSW EM

Type Motor size			OMS OMSW EM 80	OMS OMSW EM 100	OMS OMSW EM 125	OMS OMSW EM 160	OMS OMSW EM 200	OMS OMSW EM 250	OMS OMSW EM 315	OMS OMSW EM 400	OMS OMSW EM 500
Geometric displacements	cm ³ [in ³]		80.5 [4.91]	100 [6.10]	125.7 [7.67]	159.7 [9.75]	200 [12.20]	250 [15.26]	314.9 [19.22]	393.0 [23.98]	488 [29.78]
Max. speed	min ⁻¹ rpm	cont.	810	750	600	470	375	300	240	190	155
		int.	1000	900	720	560	450	360	285	230	185
Max torque	Nm [lbf·in]	cont.	240 [2120]	305 [2700]	375 [3320]	490 [4340]	610 [5400]	720 [6370]	825 [7300]	865 [7660]	850 [7520]
		int.	310 [2740]	390 [3450]	490 [4340]	600 [5310]	720 [6370]	870 [7700]	1000 [8850]	990 [8760]	990 [8760]
Max. output	kW [hp]	cont.	15.5 [20.8]	18.0 [24.1]	18.0 [24.1]	16.5 [22.1]	16.5 [22.1]	14.5 [19.4]	15.0 [20.1]	11.0 [14.8]	9.0 [12.1]
		int. ¹⁾	19.5 [26.2]	22.5 [30.2]	22.5 [30.2]	23.0 [30.8]	22.0 [29.5]	18.0 [24.1]	17.0 [22.8]	12.5 [16.8]	10.5 [14.1]
Max. pressure drop	bar [psi]	cont.	210 [3050]	210 [3050]	210 [3050]	210 [3050]	210 [3050]	200 [2900]	200 [2900]	160 [2320]	120 [1740]
		int. ¹⁾	275 [3990]	275 [3990]	275 [3990]	260 [3770]	250 [3630]	250 [3630]	240 [3480]	190 [2760]	140 [2030]
		peak ²⁾	295 [4280]	295 [4280]	295 [4280]	280 [4060]	270 [3920]	270 [3920]	260 [3770]	210 [3050]	160 [2320]
Max. oil flow	l/min [US gal/min]	cont.	65 [17.2]	75 [19.8]	75 [19.8]	75 [19.8]	75 [19.8]	75 [19.8]	75 [19.8]	75 [19.8]	75 [19.8]
		int. ¹⁾	80 [21.1]	90 [23.8]	90 [23.8]	90 [23.8]	90 [23.8]	90 [23.8]	90 [23.8]	90 [23.8]	90 [23.8]
Max. starting pressure with unloaded shaft	bar [psi]		12 [175]	10 [145]	10 [145]	8 [115]	8 [115]	8 [115]	8 [115]	8 [115]	8 [115]
Min starting torque	Nm [lbf·in]	at max press. drop cont.	180 [1590]	230 [2040]	290 [2570]	370 [3270]	470 [4160]	560 [4960]	710 [6280]	710 [6280]	660 [5840]
		at max. press. drop int. ¹⁾	235 [2080]	300 [2669]	380 [3360]	460 [4070]	560 [4960]	700 [6200]	850 [7520]	840 [7430]	770 [6820]
Frequency	[Hz]	max.	917	825	660	513	413	330	285	211	170

¹⁾ Intermittent operation: the permissible values may occur for max. 10% of every minute.

²⁾ Peak load: the permissible values may occur for max. 1% of every minute.

Type		Max. inlet pressure	Max. return pressure with drain line
OMS EM and OMSW EM	bar [psi] cont.	230 [3340]	140 [2030]
	bar [psi] int. ¹⁾	295 [4280]	175 [2540]
	bar [psi] peak ²⁾	300 [4350]	210 [3050]

¹⁾ Intermittent operation: the permissible values may occur for max. 10% of every minute.

²⁾ Peak load: the permissible values may occur for max. 1% of every minute.

[For further technical specifications please see technical information for OMS, OMT and OMV \(520L0407\)](#)

Technical Data OMS EM

Max. Permissible Shaft Seal Pressure

OMS EM with standard shaft seal, check valves and without use of drain connection:

The pressure on the shaft seal never exceeds the pressure in the return line.

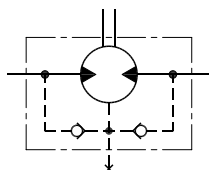

151-320.10

OMS EM with standard shaft seal, check valves and with drain connection:

The shaft seal pressure equals the pressure on the drain line

Max. return pressure without drain line or max. pressure in drain line

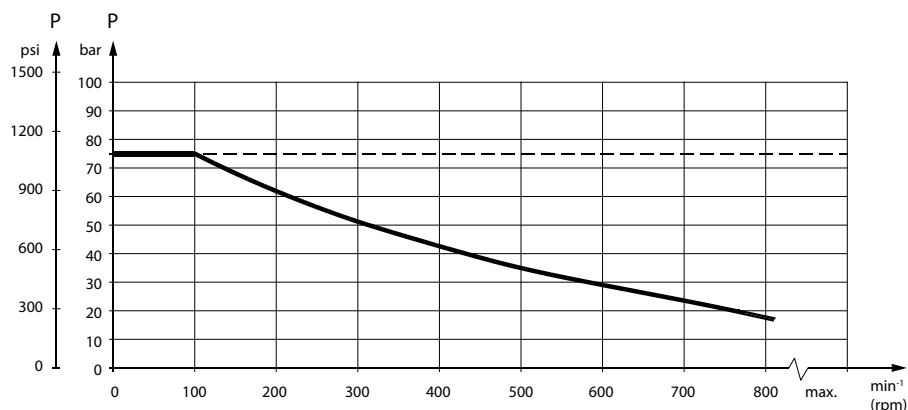

151-1674.10

--- Intermittent operation: the permissible values may occur for max. 10% of every minute.

___ Continuous operation

Technical Data OMS EM

Pressure Drop in Motor

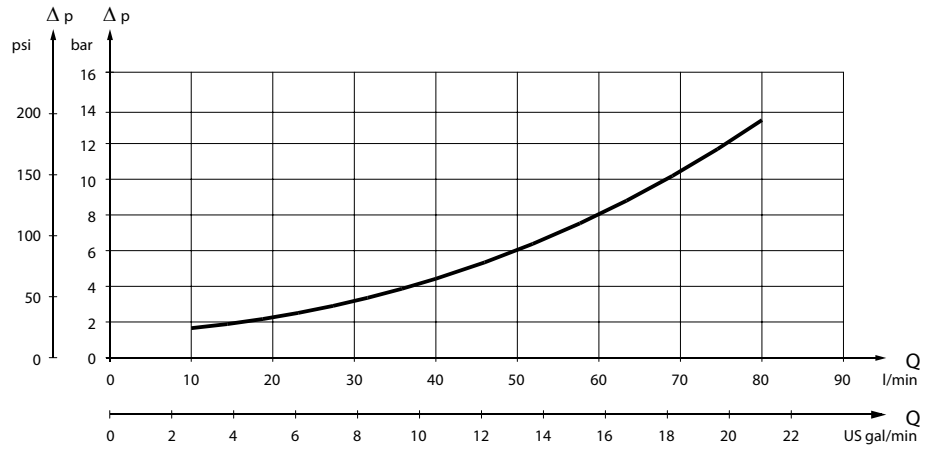

151-1408.10

The curve applies to an unloaded motor shaft and an oil viscosity of 35 mm²/s (165 SUS)

Technical Information Orbital Motors with Speed Sensor

Technical Data OMT EM

Technical data for OMT EM

Type Motor size			OMT EM 160	OMT EM 200	OMT EM 250	OMT EM 315	OMT EM 400	OMT EM 500
Geometric displacements	cm ³ [in ³]		161.1 [9.83]	201.4 [12.29]	251.8 [15.37]	326.3 [19.91]	410.9 [25.07]	523.6 [31.95]
Max. speed	min ⁻¹ rpm	cont.	625	625	500	380	305	240
		int.	780	750	600	460	365	285
Max torque	Nm [lbf·in]	cont.	470 [4160]	590 [5220]	730 [6460]	950 [8410]	1080 [9560]	1220 [10800]
		int.	560 [4960]	710 [6280]	880 [7790]	1140 [10090]	1260 [11150]	1370 [12130]
Max. output	kW [hp]	cont.	26.5 [35.5]	33.5 [44.9]	33.5 [44.9]	33.5 [44.9]	30.0 [40.2]	26.5 [35.5]
		int. ¹⁾	32.0 [42.9]	40.0 [53.6]	40.0 [53.6]	40.0 [53.6]	35.0 [46.9]	30.0 [40.2]
Max. pressure drop	bar [psi]	cont.	200 [2900]	200 [2900]	200 [2900]	200 [2900]	180 [2610]	160 [2320]
		int. ¹⁾	240 [3480]	240 [3480]	240 [3480]	240 [3480]	210 [3050]	180 [2610]
		peak ²⁾	280 [4060]	280 [4060]	280 [4060]	280 [4060]	240 [3480]	210 [3050]
Max. oil flow	l/min [US gal/min]	cont.	100 [26.4]	125 [33.0]	125 [33.0]	125 [33.0]	125 [33.0]	125 [33.0]
		int. ¹⁾	125 [33.0]	150 [39.6]	150 [39.6]	150 [39.6]	150 [39.6]	150 [39.6]
Max. starting pressure with unloaded shaft	bar [psi]		10 [145]	10 [145]	10 [145]	10 [145]	10 [145]	10 [145]
Min starting torque	Nm [lbf·in]	at max. press. drop cont.	340 [3010]	430 [3810]	530 [4690]	740 [6550]	840 [7430]	950 [8410]
		at max. press. drop int. ¹⁾	410 [3630]	520 [4600]	630 [5580]	890 [7880]	970 [8590]	1060 [9380]
Frequency	[Hz]	max.	1014	975	780	598	475	371

¹⁾ Intermittent operation: the permissible values may occur for max. 10% of every minute.

²⁾ Peak load: the permissible values may occur for max. 1% of every minute.

Type		Max. inlet pressure	Max. return pressure with drain line
OMT EM	bar [psi] cont.	210 [3050]	140 [2030]
	bar [psi] int. ¹⁾	250 [3630]	175 [2540]
	bar [psi] peak ²⁾	300 [4350]	210 [3050]

¹⁾ Intermittent operation: the permissible values may occur for max. 10% of every minute.

²⁾ Peak load: the permissible values may occur for max. 1% of every minute.

[For further technical specifications please see technical information for OMS, OMT and OMV \(520L0407\)](#)

Technical Data OMT EM

Max. Permissible Shaft Seal Pressure

OMT EM with check valves and without use of drain connection:

The pressure on the shaft seal never exceeds the pressure in the return line.

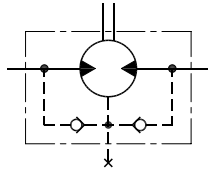

151-320.10

OMT EM with check valves and with drain connection:

The shaft seal pressure equals the pressure on the drain line

Max. return pressure without drain line or max. pressure in drain line

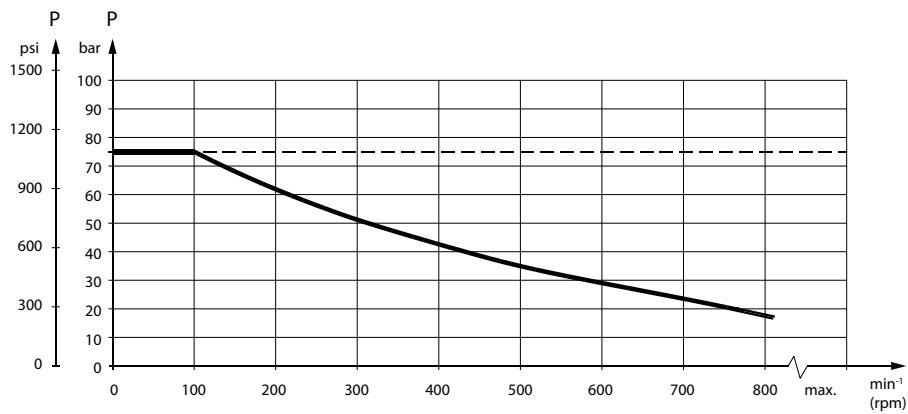

151-1674.10

--- Intermittent operation: the permissible values may occur for max. 10% of every minute.

___ Continuous operation

Technical Data OMT EM

Pressure Drop in Motor

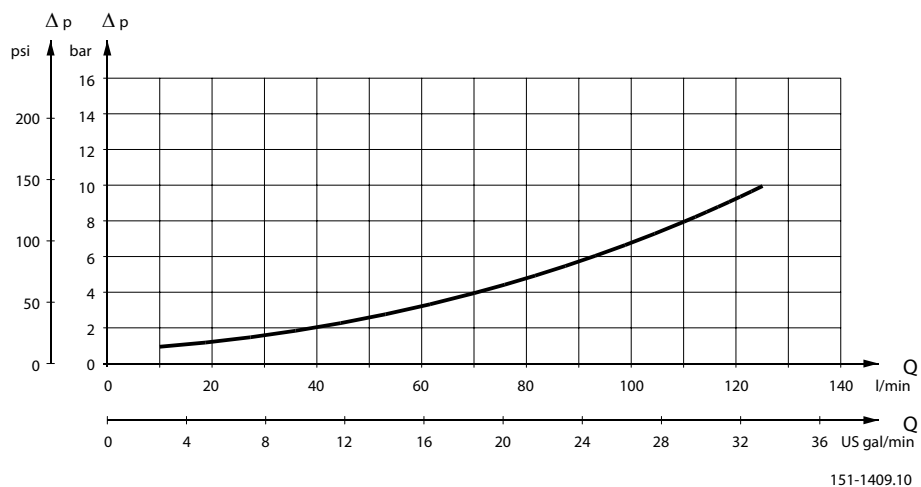

The curve applies to an unloaded motor shaft and an oil viscosity of 35 mm²/s (165 SUS)

Technical Information Orbital Motors with Speed Sensor

Technical Data OMV EM

Technical data for OMV EM

Type Motorsize			OMV EM 315	OMV EM 400	OMV EM 500	OMV EM 630	OMV EM 800
Geometric displacements	cm ³ [in ³]		314.5 [19.19]	400.9 [24.46]	499.6 [30.49]	629.1 [38.39]	801.8 [48.93]
Max. speed	min ⁻¹ rpm	cont.	510	500	400	315	250
		int.	630	600	480	380	300
Max torque	Nm [lbf·in]	cont.	920 [8140]	1180 [10440]	1460 [12920]	1660 [14690]	1880 [16640]
		int.	1110 [9820]	1410 [12480]	1760 [15580]	1940 [17170]	2110 [18680]
Max. output	kW [hp]	cont.	42.5 [57.0]	53.5 [71.7]	53.5 [71.7]	48.0 [64.4]	42.5 [57.0]
		int. ¹⁾	51.0 [68.4]	64.0 85.8]	64.0 [85.8]	56.0 [75.1]	48.0 [64.4]
Max. pressure drop	bar [psi]	cont.	200 [2900]	200 [2900]	200 [2900]	180 [2610]	160 [2320]
		int. ¹⁾	240 [3480]	240 [3480]	240 [3480]	210 [3050]	180 [2610]
		peak ²⁾	280 [4060]	280 [4060]	280 [4060]	240 [3480]	210 [3050]
Max. oil flow	l/min [US gal/min]	cont.	160 [42.3]	200 [52.8]	200 [52.8]	200 [52.8]	200 [52.8]
		int. ¹⁾	200 [52.8]	240 [63.4]	240 [63.4]	240 [63.4]	240 [63.4]
Max. starting pressure with unloaded shaft	bar [psi]		8 [116]	8 [116]	8 [116]	8 [116]	8 [116]
Min starting torque	Nm [lbf·in]	at max. press drop cont.	710 [6280]	910 [8050]	1130 [10000]	1330 [11770]	1510 [13360]
		at max. press.drop int. ¹⁾	850 [7520]	1090 [9650]	1360 [12040]	1550 [13720]	1700 [15050]
Frequency	[Hz]	max.	1071	1020	816	646	510

¹⁾ Intermittent operation: the permissible values may occur for max. 10% of every minute.

²⁾ Peak load: the permissible values may occur for max. 1% of every minute.

Type		Max. inlet pressure	Max. return pressure with drain line
OMV EM	bar [psi] cont.	210 [3050]	140 [2030]
	bar [psi] int. ¹⁾	250 [3630]	175 [2540]
	bar [psi] peak ²⁾	300 [4350]	210 [3050]

¹⁾ Intermittent operation: the permissible values may occur for max. 10% of every minute.

²⁾ Peak load: the permissible values may occur for max. 1% of every minute.

[For further technical specifications please see technical information for OMS, OMT and OMV \(520L0407\)](#)

Technical Data OMV EM

Max. Permissible Shaft Seal Pressure

OMV EM with check valves and without use of drain connection:

The pressure on the shaft seal never exceeds the pressure in the return line.

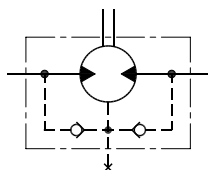

151-320.10

OMV EM with check valves and with drain connection:

The shaft seal pressure equals the pressure on the drain line

Max. return pressure without drain line or max. pressure in drain line

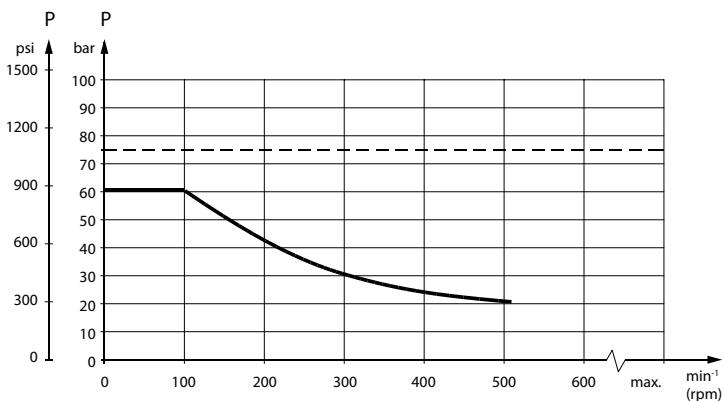

151-1673.10

--- Intermittent operation: the permissible values may occur for max. 10% of every minute.

___ Continuous operation

Pressure drop in motor

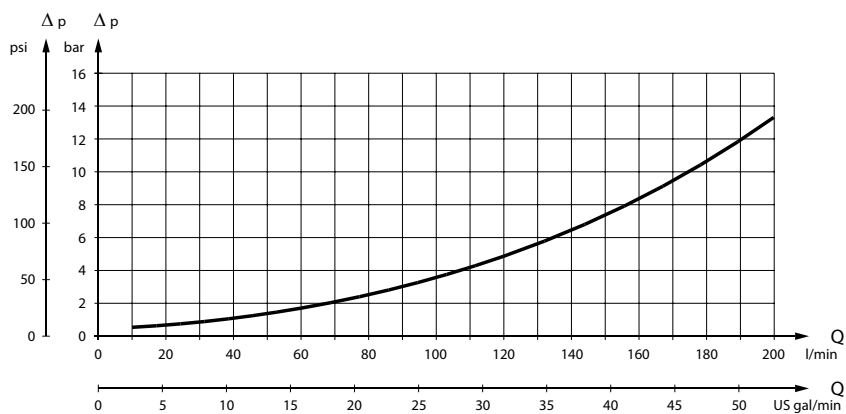

151-1410.10

The curve applies to an unloaded motor shaft and an oil viscosity of 35 mm²/s (165 SUS)

Technical Data Speed Sensor

Technical Data Speed Sensor

Mechanical data:

Temperatur range: -30°C to +90°C

Enclosure acc. to IEC 529: IP 67

Electrical data

Principle: Hall

Supply voltage: 11 - 30V

Load max.: $I_{high} = I_{low} \pm 50 \text{ mA}$

No load current, max.: 20 mA

Output signal:

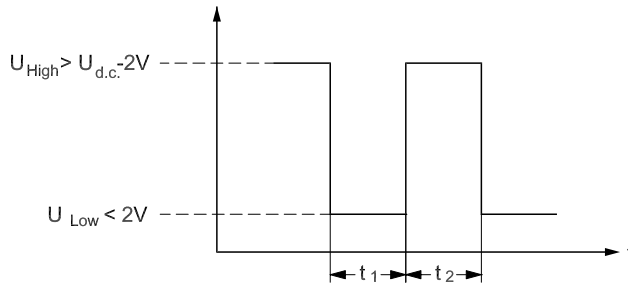

$$t_1 = t_2 \pm 10\%$$

159G33.11

Connection type			
	Binder Series 713	Molded in cable	Connection
Terminal no.:	1	brown	UDC (+supply)
	2	White	No connection
	3	Blue	UDC (-supply)
	4	Black	Output signal
Protection: Protected against short circuit and incorrect polarization.			

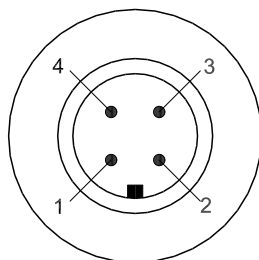

159G82.10

Technical Data Speed Sensor

Revolution:

Pulses per revolution (PPR)	OMM EM	OMP EM	OMR EM	OMS EM	OMSW EM	OMT EM	OMV EM
	22	35	35	55	55	84	102

Calculation of frequency:

$$f_r = \frac{\text{RPM} \cdot \text{PPR}}{60} \text{ [Hz]}$$

Wiring Diagram

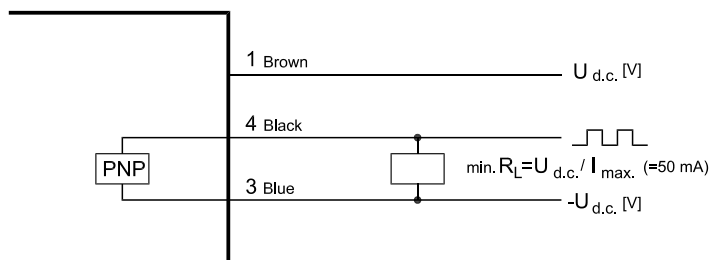

159G34.10

Speed Sensor with Plug Connection Dimensions

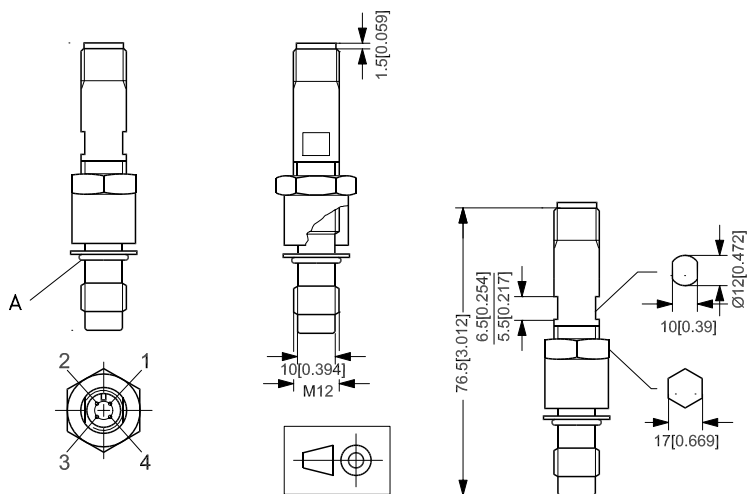

159G83.10

159G84.12

Technical Data Speed Sensor

Speed Sensor with Molded in Cable Dimensions

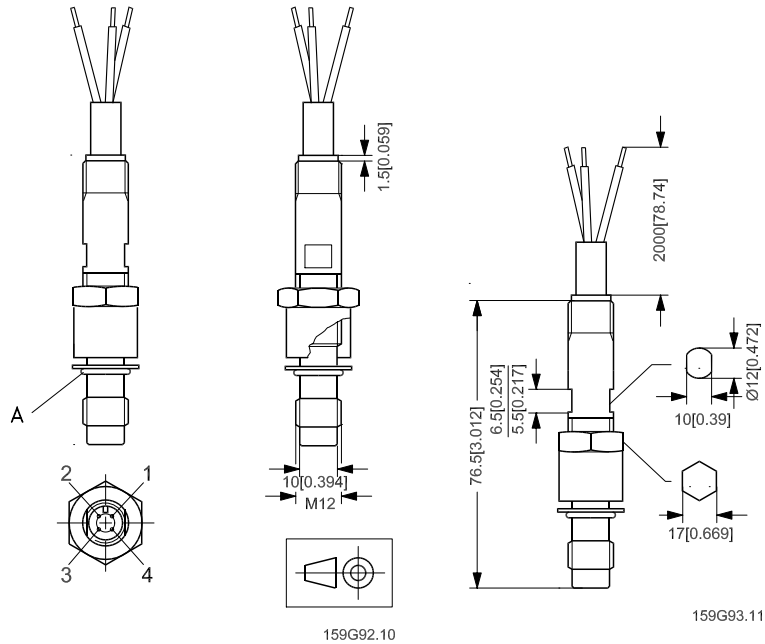

Spare Parts

Speed sensor

Code numbers

Type	Code no.
Sensor with plug (PNP output)	151-5662
Sensor with 2 m [6.56 ft] molded in cable (PNP output)	151-5663
Sensor with 5.5 m [18.04 ft] moulded in cable (PNP output)	151-5667
Sensor with plug (NPN output)	151-5833

Accessories

Cable with plug

Code numbers

Cable length 5 m [16.4 ft]	984F0101
----------------------------	----------

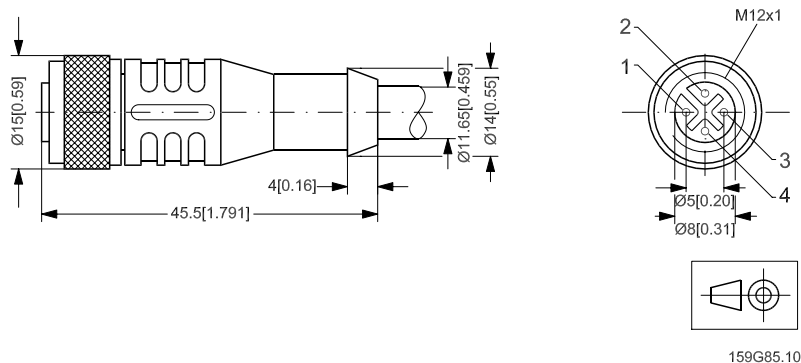
Technical Data Speed Sensor

Wire (shield)

Core: Cu, 4 • 0.34 mm²

Sheath: PUR/PVC, colour: grey

Plug

Type: Binder, Series 713

Cable no:	1	brown
	2	white
	3	blue
	4	black

Temperature range: -30 °C to +80 °C

Enclosure acc. to IEC 529: IP 67

Shaft Versions

Shaft Versions

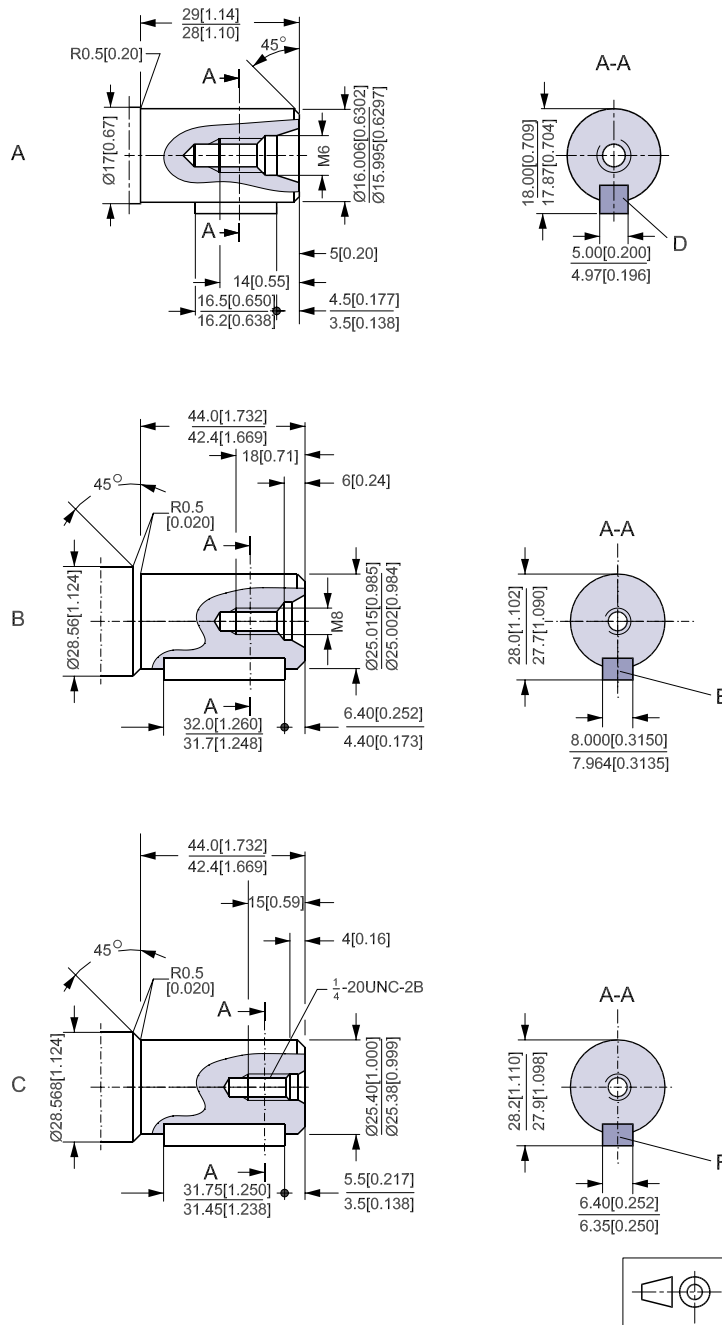

151-2069.10

OMM
 A: Cylindrical shaft
 16 mm
 D: Parallel key
 A5 • 5 • 16
 DIN 6885

OMP/OMR
 A: Cylindrical shaft
 25 mm
 D: Parallel key
 A8 • 7 • 32
 DIN 6885

OMR US Version
 C: Cylindrical shaft
 1 in
 F: Parallel key
 1/4 1/4 1 1/4 in
 B.S. 46

Shaft Versions

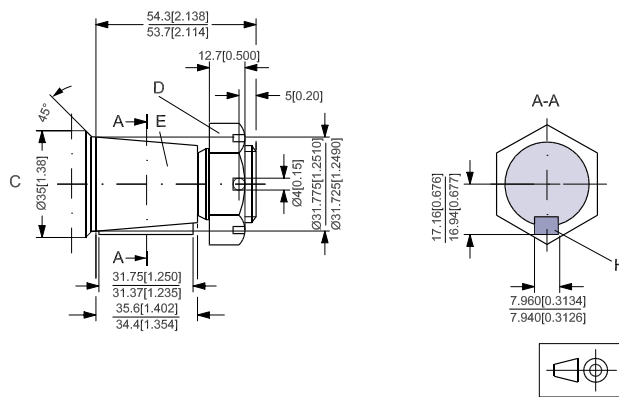
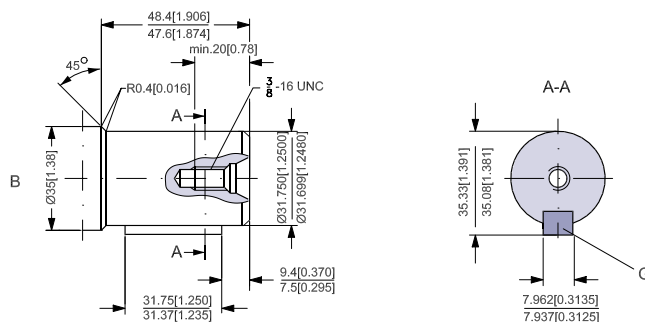
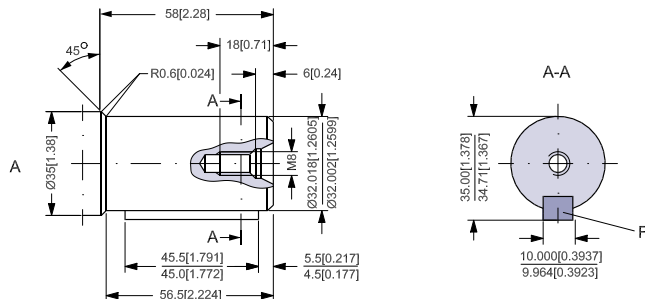

151-2070.10

OMS

A: Cylindrical shaft
32 mm
D: Parallel key
A10 • 8 • 45
DIN 6885

OMS US Version

B: Cylindrical shaft
1.25 in shaft
E: Parallel key
5/16 × 5/16 × 11/4 in
SAE J744

OMSW US Version

I: Tapered 1 1/4 in shaft
N: Cone 1:8
SAE J501
M: 1 - 20 UNEF
Across flats 1 7/16 in
Tightening torque:
200 ± 10 Nm (1770 ± 85 lbf-in)
O: Parallel key
5/16 × 5/16 × 1 1/4
SAE J501

Shaft Versions

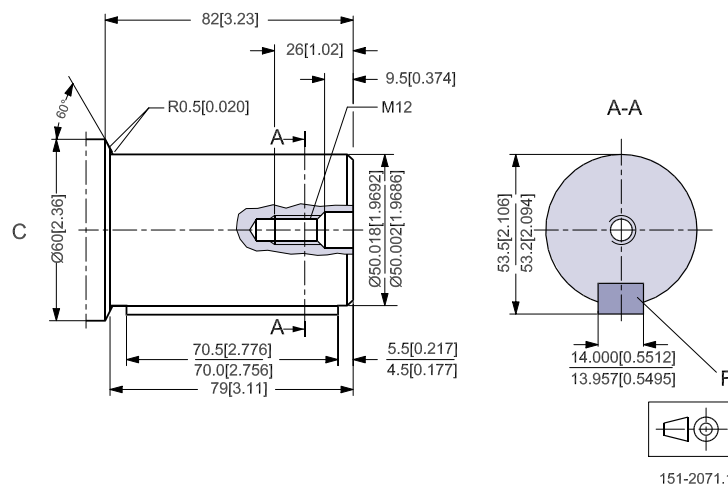
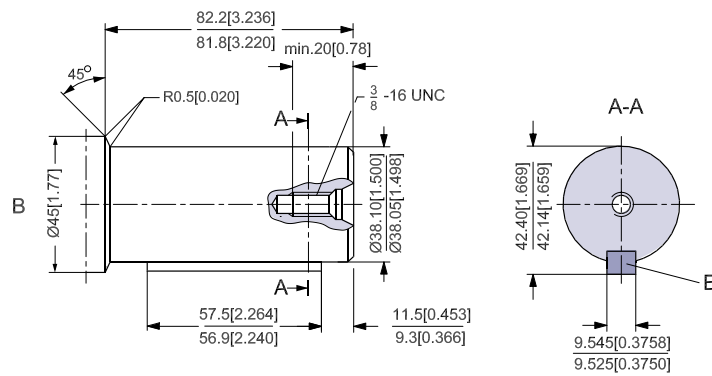
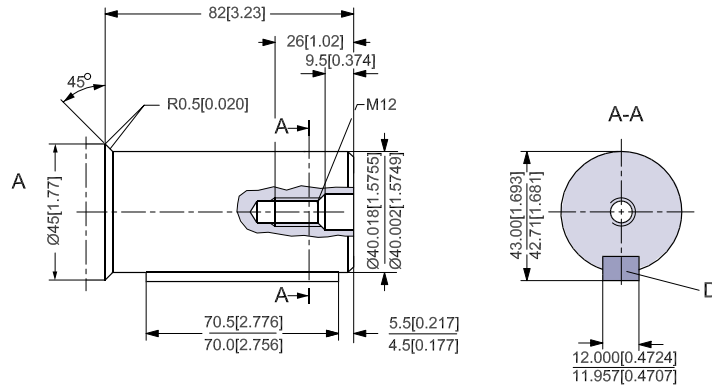

OMT
 A: Cylindrical shaft; 40 mm
 C: Parallel key
 A12 • 8 • 70; DIN 6885

OMT US Version
 B: Cylindrical 1.5 in shaft
 D: Parallel key
 3/8 x 3/8 x 21/4 in; B.S.46

OMV
 A: Cylindrical shaft; 50 mm
 C: Parallel key
 A14 • 9 • 70; DIN 6885

Port Thread Versions

Port Thread Versions

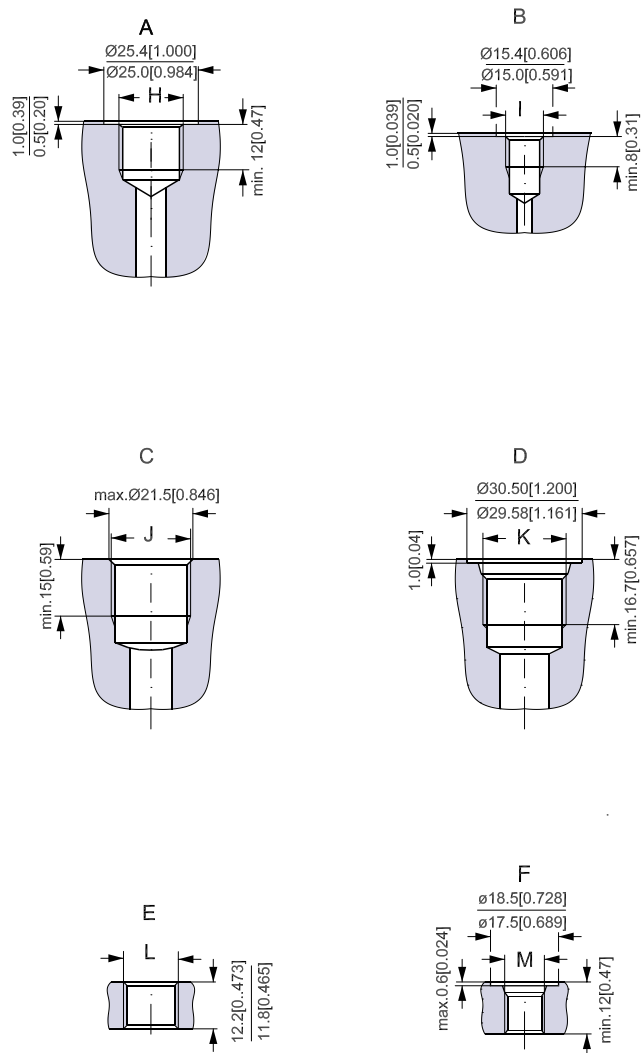

151-2072.10

OMM

A: G main ports B: UNF main ports
H: ISO 228/1 - G3/8 I: ISO 228/1 - G1/8

OMP/OMR

C: G main ports D: UNF main ports
J: ISO 228/1 - G1/2 K: 7/8 - 14 UNF, O-ring boss port
E: G drain port F: UNF drain port
L: ISO 228/1 - G1/4 M: 7/16 - 20 UNF, O-ring boss port

Port Thread Versions

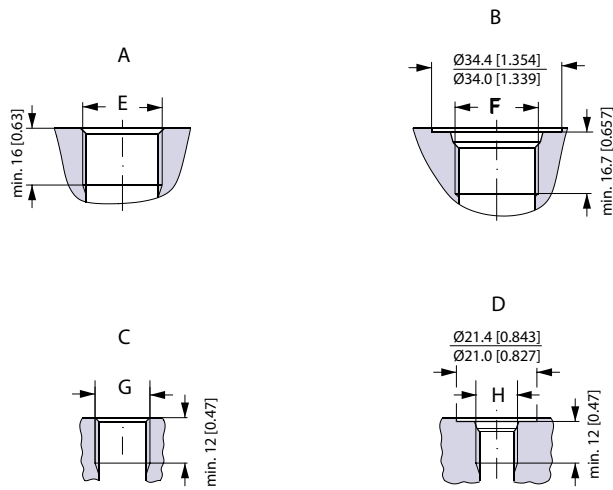

151-1971.11

OMS/OMSW

- A: G main ports B: UNF main ports
- E: ISO 228/1 - G1/2 F: 7/8 - 14 UNF, O-ring boss port
- C: G drain port D: UNF drain port
- G: ISO 228/1 - G1/4 H: 7/16 - 20 UNF, O-ring boss port

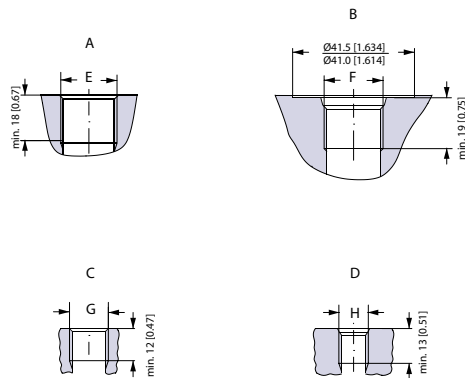

151-1977.11

OMT

- A: G main ports B: UN main ports
- E: ISO 228/1 - G3/4 F: 1 1/16 - 12 UN, O-ring boss port
- C: G drain port D: UNF drain port
- G: ISO 228/1 - G1/4 H: 9/16 - 20 UNF, O-ring boss port

Port Thread Versions

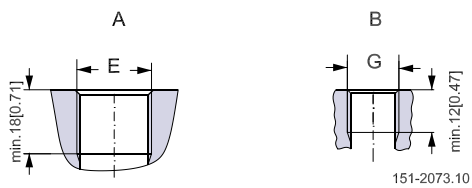

OMV

A: G Main port B : G drain port

E: ISO 228/1 - G1 G: ISO 228/1 - G1/4

Dimensions - European Version

	Lmax mm [in]	L1 mm [in]
OMM 8 EM	109 [4.29]	3.5 [0.14]
OMM 12.5 EM	111 [4.37]	5.5 [0.22]
OMM 20 EM	114 [4.49]	8.5 [0.33]
OMM 32 EM	119 [4.68]	13.5 [0.53]
OMM 50 EM	127 [5.00]	21.5 [0.85]

Dimensions - European Version

OMM EM End Port Version

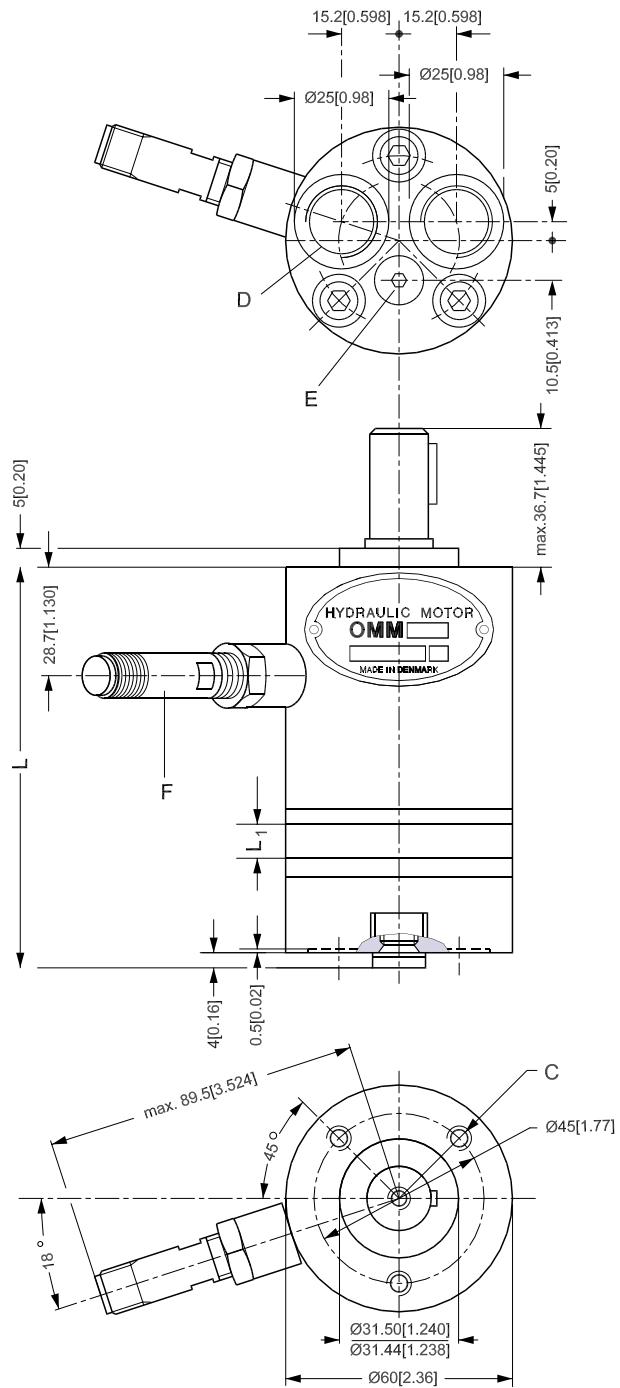

159G13.10

- C : M6; 10 mm deep
- D : G3/8 ; 12 mm deep
- E : Drain connection G1/8 ; 8 mm deep
- F : Plug connection: Binder Series 713

Dimensions - European Version

	Lmax mm [in]	L1 mm [in]
OMP 50 EM	131.4 [5.17]	9.0 [0.35]
OMP 80 EM	135.3 [5.33]	14.0 [0.55]
OMP 100 EM	137.9 [5.43]	17.4 [0.68]
OMP 160 EM	145.7 [5.74]	21.8 [0.86]
OMP 200 EM	150.9 [5.94]	27.8 [1.09]
OMP 250 EM	157.4 [6.20]	34.8 [1.37]
OMP 315 EM	165.8 [6.53]	43.5 [1.71]
OMP 400 EM	176.9 [6.96]	54.8 [2.16]

Dimensions - US Version

OMP EM Side Port Version with 2 Hole Oval Mounting Flange (A2-flange) with Drain Connection

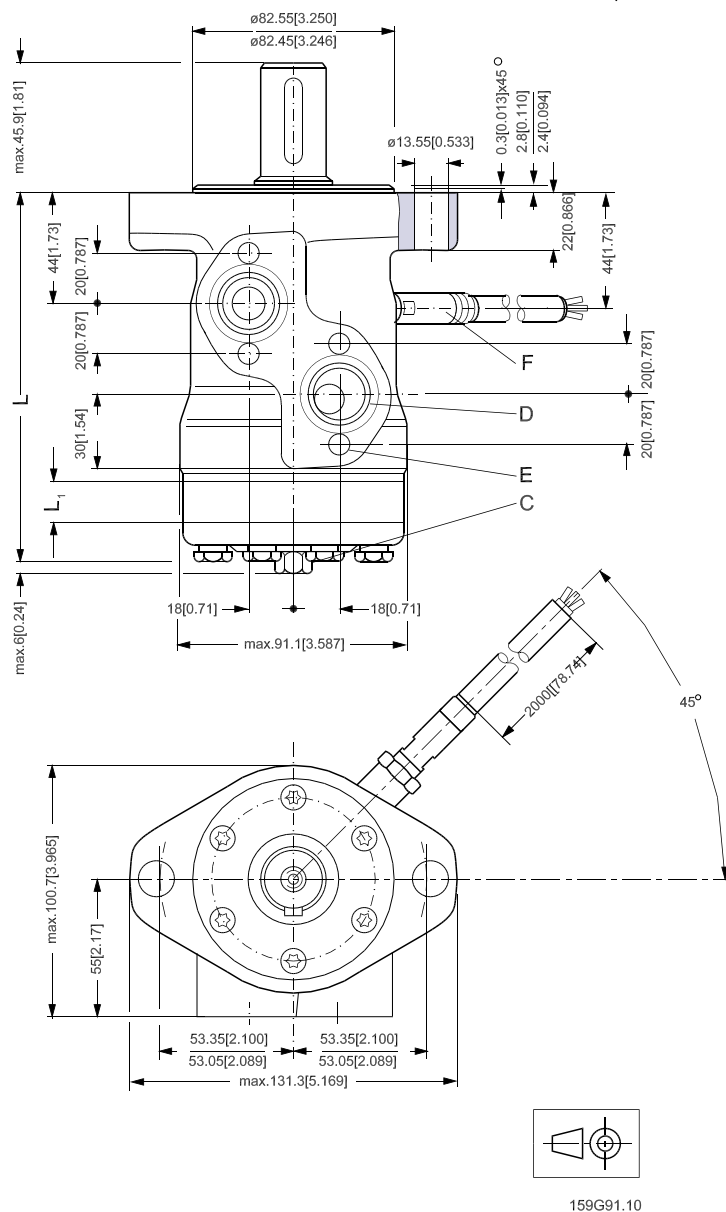

C : Drain connection 7/16 - 20 UNF; 12 mm [0.47 in] deep

D : 7/8 - 14 UNF; 16.7 mm [0.66 in] deep or 1/2 - 14 NPTF

E : M8; 13 mm [0.51 in] deep (4 off)

F : Plug connection: 2 m [6.56 ft] molded in cable

	Lmax mm [in]	L1 mm [in]
OMP 50 EM	131.4 [5.17]	9.0 [0.35]
OMP 80 EM	135.3 [5.33]	14.0 [0.55]
OMP 100 EM	137.9 [5.43]	17.4 [0.68]

Technical Information Orbital Motors with Speed Sensor

Dimensions - US Version

	Lmax mm [in]	L1 mm [in]
OMP 160 EM	145.7 [5.74]	21.8 [0.86]
OMP 200 EM	150.9 [5.94]	27.8 [1.09]
OMP 250 EM	157.4 [6.20]	34.8 [1.37]
OMP 315 EM	165.8 [6.53]	43.5 [1.71]
OMP 400 EM	176.9 [6.96]	54.8 [2.16]

Dimensions - European Version

	Lmax mm [in]	L1 mm [in]
OMR 50 EM	136.1 [5.36]	9.0 [0.35]
OMR 80 EM	141.1 [5.55]	14.0 [0.55]
OMR 100 EM	144.5 [5.69]	17.4 [0.68]
OMR 125 EM	148.9 [5.86]	21.8 [0.86]
OMR 160 EM	154.9 [6.10]	27.8 [1.09]
OMR 200 EM	161.9 [6.37]	34.8 [1.37]
OMR 250 EM	170.6 [6.72]	43.5 [1.71]
OMR 315 EM	181.9 [7.16]	54.8 [2.16]
OMR 375 EM	192.1 [7.56]	65.0 [2.56]

Dimensions - US Version

OMR EM Side Port Version with 2 Hole Oval Mounting Flange (A2-flange) with Drain Connection

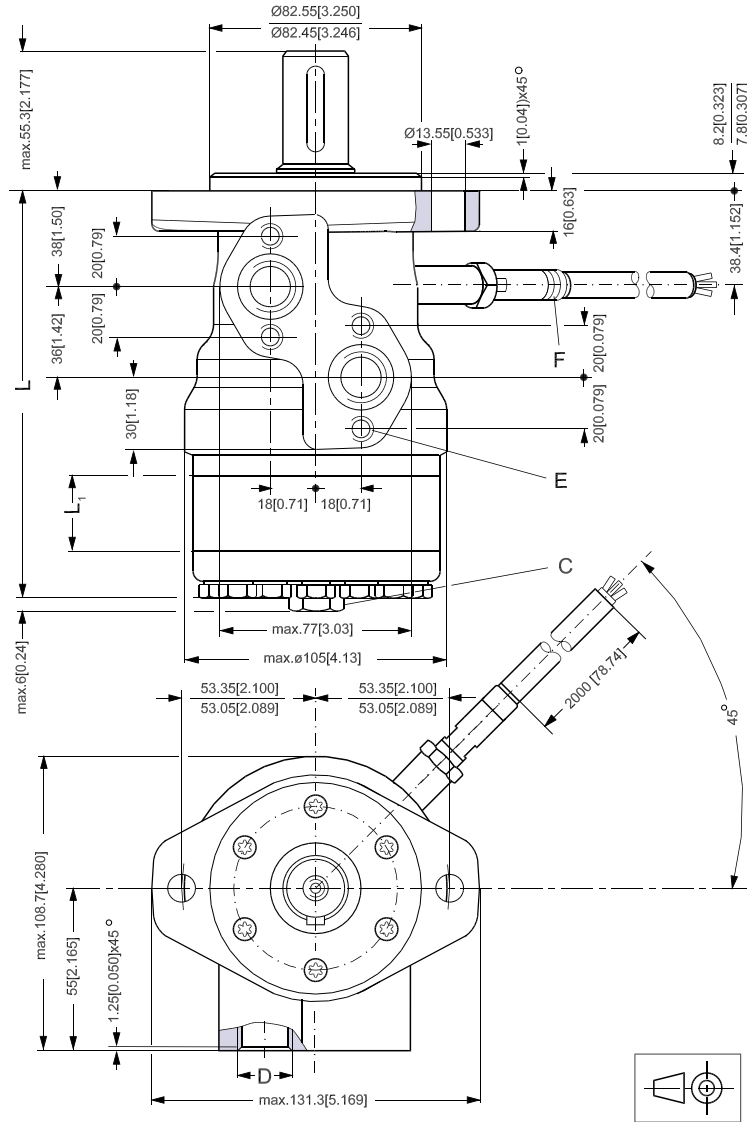

159G90.11

C : Drain connection 7/16 - 20 UNF; 12 mm [0.47 in] deep

D : 7/8 - 14 UNF; 16.7 mm [0.66 in] deep or 1/2 - 14 NPTF

E : M8; 13 mm [0.51 in] deep (4 off)

F : Plug connection: 2 m [6.56 ft] molded in cable

Type	Lmax mm [in]	L1 mm [in]
OMR 50 EM	136.1 [5.36]	9.0 [0.35]
OMR 80 EM	141.1 [5.55]	14.0 [0.55]
OMR 100 EM	144.5 [5.69]	17.4 [0.68]
OMR 125 EM	148.9 [5.86]	21.8 [0.86]
OMR 160 EM	154.9 [6.10]	27.8 [1.09]

Technical Information Orbital Motors with Speed Sensor

Dimensions - US Version

Type	Lmax mm [in]	L1 mm [in]
OMR 200 EM	161.9 [6.37]	34.8 [1.37]
OMR 250 EM	170.6 [6.72]	43.5 [1.71]
OMR 315 EM	181.9 [7.16]	54.8 [2.16]
OMR 375 EM	192.1 [7.56]	65.0 [2.56]

Dimensions - European Version

OMS EM

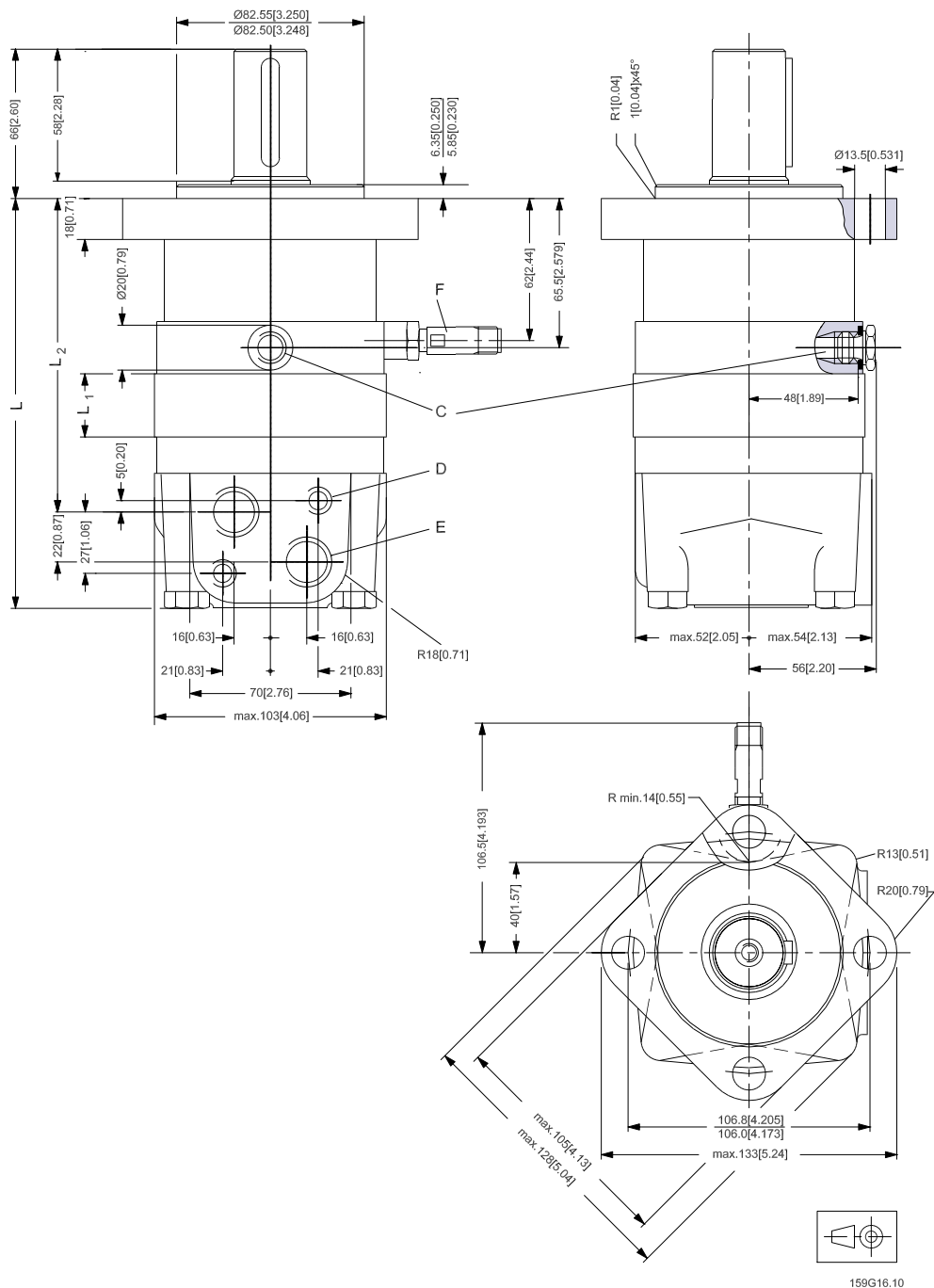

C: Drain connection G 1/4 ; 12 mm [0.47 in] deep

D: M10; 13 mm [0.51 in] deep

E: G 1/2 ; 15 mm [0.59 in] deep

F : Plug connection: Binder Series 713

Dimensions - European Version

Type	Lmax mm [in]	L1 mm [in]	L2 mm [in]
OMS 80 EM	167 [6.57]	14.0 [0.551]	124 [4.88]
OMS 100 EM	170 [6.69]	17.4 [0.685]	127 [5.00]
OMS 125 EM	175 [6.89]	21.8 [0.858]	132 [5.20]
OMS 160 EM	181 [7.13]	27.8 [1.094]	138 [5.43]
OMS 200 EM	188 [7.40]	34.8 [1.370]	145 [5.71]
OMS 250 EM	196 [7.72]	43.5 [1.713]	153 [6.02]
OMS 315 EM	208 [8.19]	54.8 [2.157]	165 [6.50]
OMS 400 EM	221 [8.70]	68.4 [2.693]	178 [7.01]

Dimensions - US Version

OMS EM

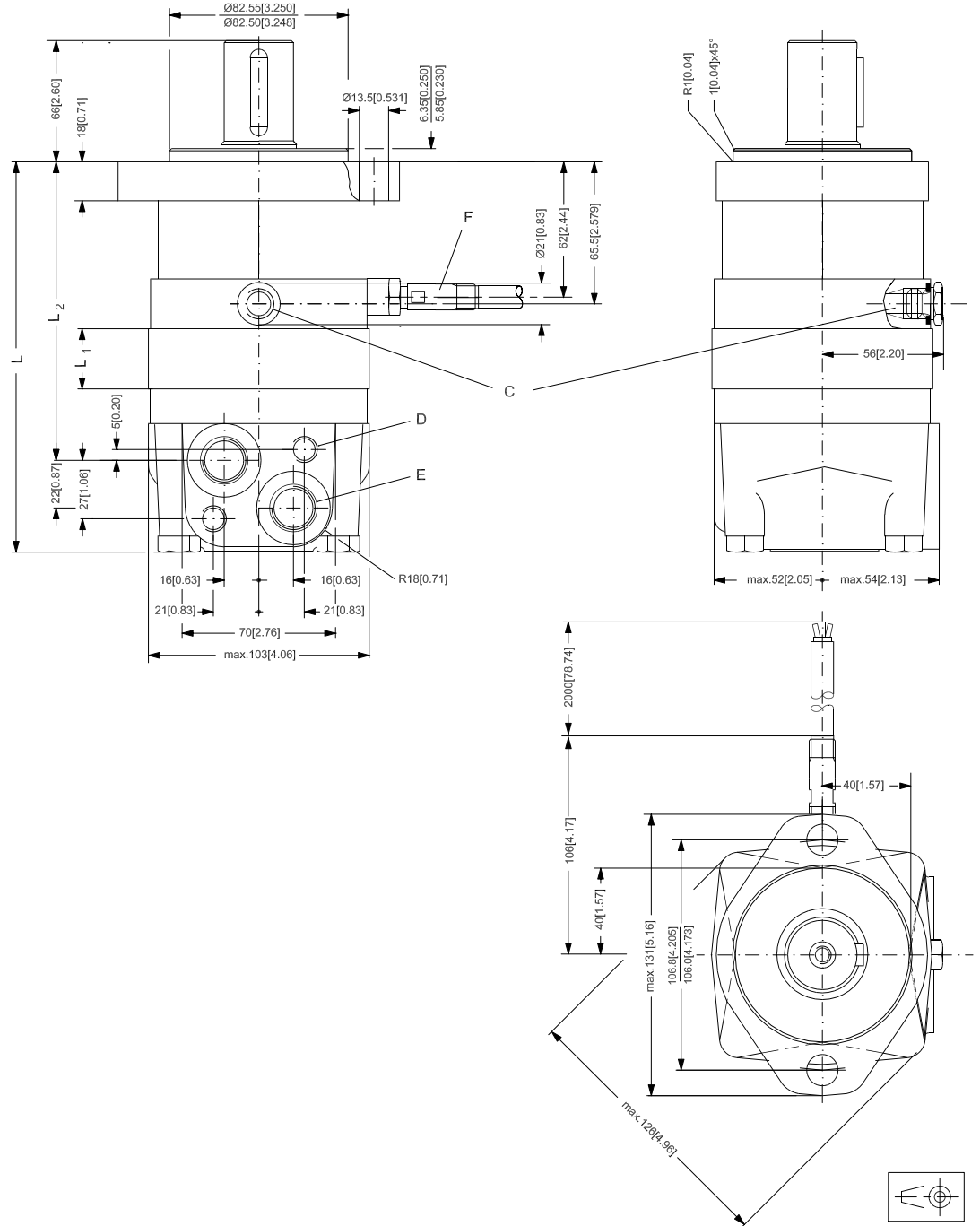

C: Drain connection 7/16 - 20 UNF; 12 mm [0.47 in] deep O-ring boss port

D: M10; 13 mm [0.51 in] deep

E: 7/8 - 14 UNF; 16.7 mm [0.657 in] deep O-ring boss port

F: Plug connection: 2 m [6.56 ft] molded in cable



159G89.11

Dimensions - US Version

Type	Lmax mm [in]	L1 mm [in]	L2 mm [in]
OMS 80 EM	167 [6.57]	14.0 [0.55]	124 [4.88]
OMS 100 EM	170 [6.69]	17.4 [0.68]	127 [5.00]
OMS 125 EM	175 [6.89]	21.8 [0.86]	132 [5.20]
OMS 160 EM	181 [7.13]	27.8 [1.09]	138 [5.43]
OMS 200 EM	188 [7.40]	34.8 [1.37]	145 [5.71]
OMS 250 EM	196 [7.72]	43.5 [1.71]	153 [6.02]
OMS 315 EM	208 [8.19]	54.8 [2.16]	165 [6.50]
OMS 400 EM	221 [8.70]	68.4 [2.69]	178 [7.01]
OMS 500 EM	221 [8.70]	68.4 [2.69]	178 [7.01]

Dimensions - US Version

OMSW EM

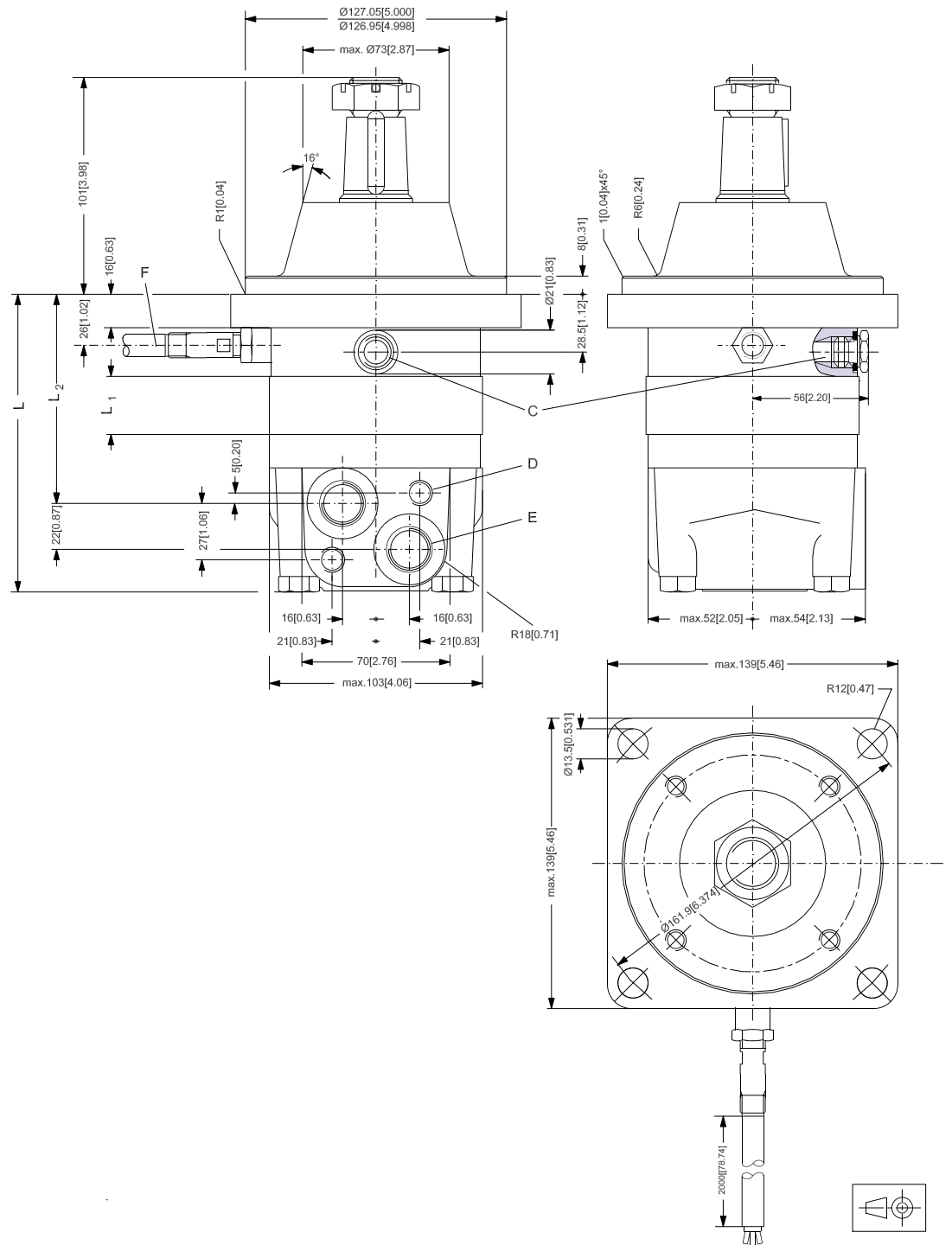

C: Drain connection 7/16 - 20 UNF; 12 mm [0.47 in] deep O-ring boss port

D: M10; 13 mm [0.51 in] deep

E: 7/8 - 14 UNF; 16.7 mm [0.657 in] deep O-ring boss port

F : Plug connection: 2 m [6.56 ft] molded in cable

Dimensions - US Version

Type	Lmax mm [in]	L1 mm [in]	L2 mm [in]
OMSW 80 EM	132 [5.20]	14.0 [0.55]	90 [3.54]
OMSW 100 EM	135 [5.31]	17.4 [0.68]	93 [3.66]
OMSW 125 EM	140 [5.51]	21.8 [0.86]	98 [3.86]
OMSW 160 EM	146 [5.75]	27.8 [1.09]	104 [4.09]
OMSW 200 EM	153 [6.02]	34.8 [1.37]	111 [4.37]
OMSW 250 EM	161 [6.34]	43.5 [1.71]	119 [4.69]
OMSW 315 EM	173 [6.81]	54.8 [2.16]	131 [5.16]
OMSW 400 EM	186 [7.32]	68.4 [2.69]	144 [5.67]
OMSW 500 EM	186 [7.32]	68.4 [2.69]	144 [5.67]

Dimensions - European Version

OMT EM

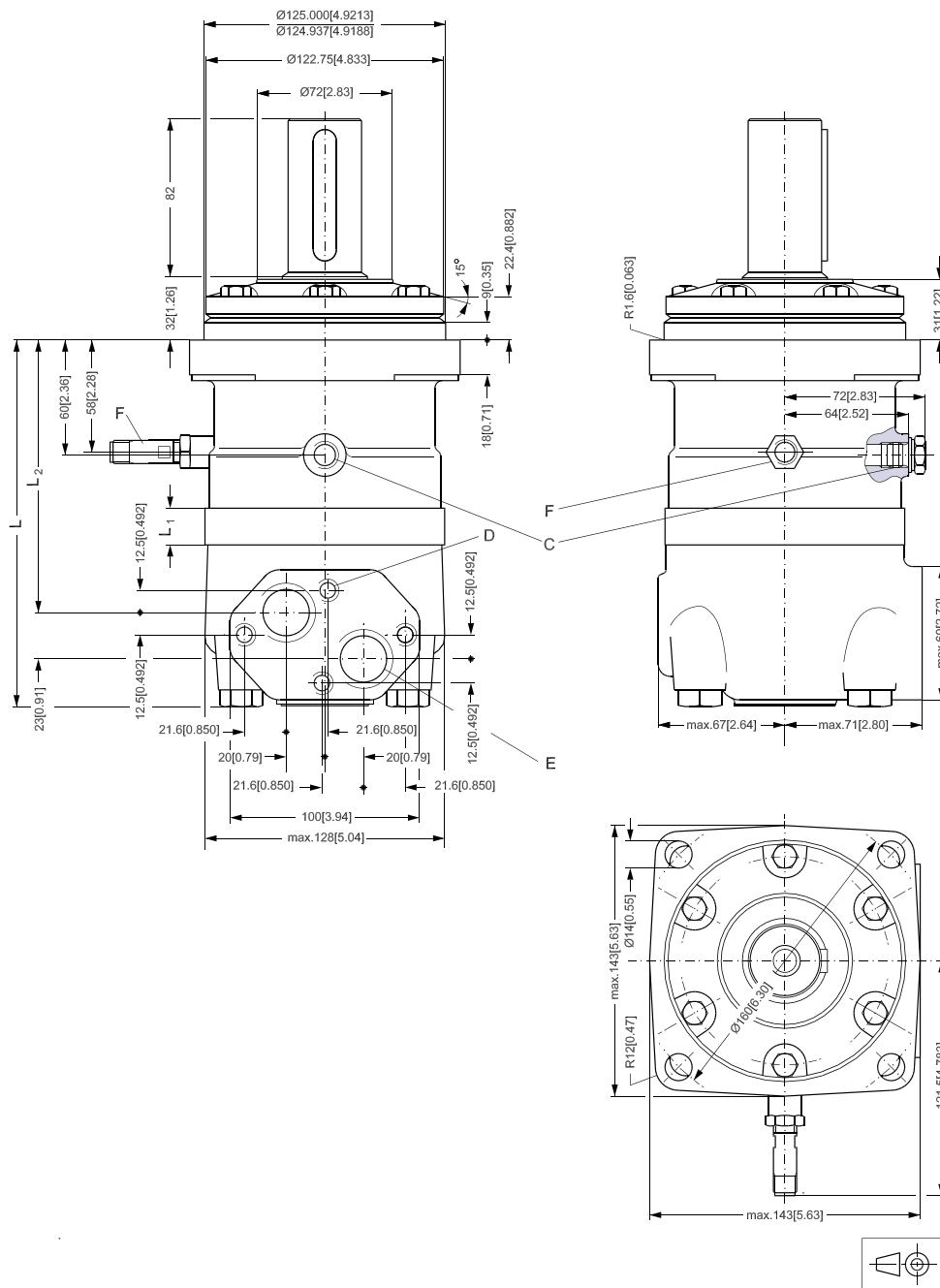

159G18.10

C: Drain connection G 1/4 ; 12 mm [0.47 in] deep

D: M10 ; 10 mm [0.39 in] deep

E: G 3/4 ; 17 mm [0.67 in] deep

F : Plug connection: Binder Series 713

Dimensions - European Version

Type	Lmax mm [in]	L1 mm [in]	L2 mm [in]
OMT 160 EM	190 [7.48]	16.5 [0.650]	140 [5.51]
OMT 200 EM	195 [7.68]	21.5 [0.846]	145 [5.71]
OMT 250 EM	201 [7.91]	27.8 [1.094]	151 [5.94]
OMT 315 EM	211 [8.31]	37.0 [1.457]	161 [6.34]
OMT 400 EM	221 [8.70]	47.5 [1.870]	171 [6.73]
OMT 500 EM	235 [9.25]	61.5 [2.421]	185 [7.28]

*) The gearwheel set is 3.5 mm [0.138 in] wider across the rollers than the L1 dimensions

Dimensions - US Version

OMT EM

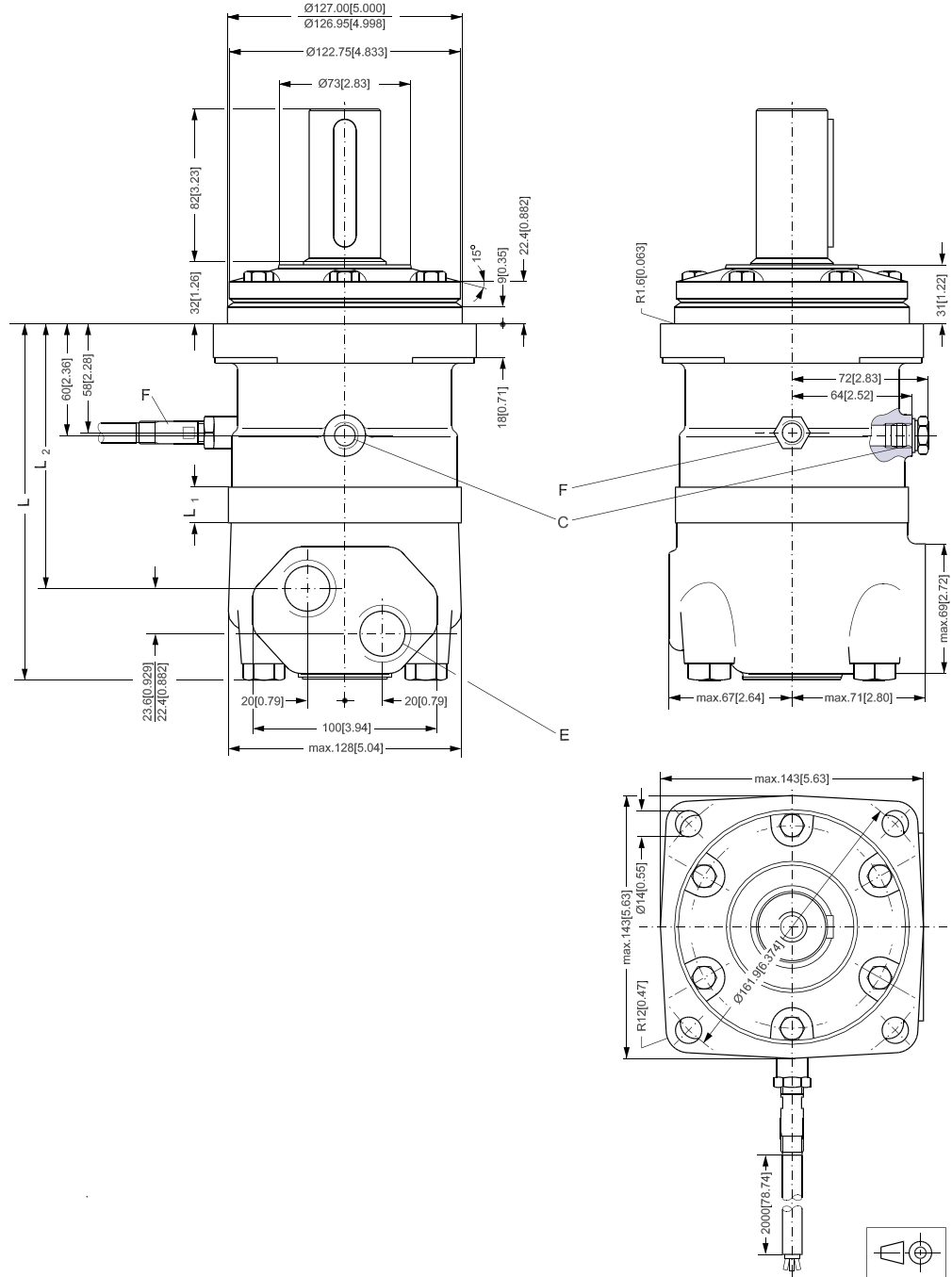

159G87.10

C: Drain connection 9/16 - 18 UNF; 13 mm [0.51 in] deep O-ring boss port

D: 1 1/16 - 12 UN; 19 mm [0.75 in] deep O-ring boss port

F: Plug connection: 2 m [6.56 ft] molded in cable

Dimensions - US Version

Type	Lmax mm [in]	L1 mm [in]	L2 mm [in]
OMT 160 EM	190 [7.48]	16.5 [0.650]	140 [5.51]
OMT 200 EM	195 [7.68]	21.5 [0.846]	145 [5.71]
OMT 250 EM	201 [7.91]	27.8 [1.094]	151 [5.94]
OMT 315 EM	211 [8.31]	37.0 [1.457]	161 [6.34]
OMT 400 EM	221 [8.70]	47.5 [1.870]	171 [6.73]
OMT 500 EM	235 [9.25]	61.5 [2.421]	185 [7.28]

*) The gearwheel set is 3.5 mm [0.138 in] wider across the rollers than the L1 dimensions

Dimensions - European Version

OMV EM

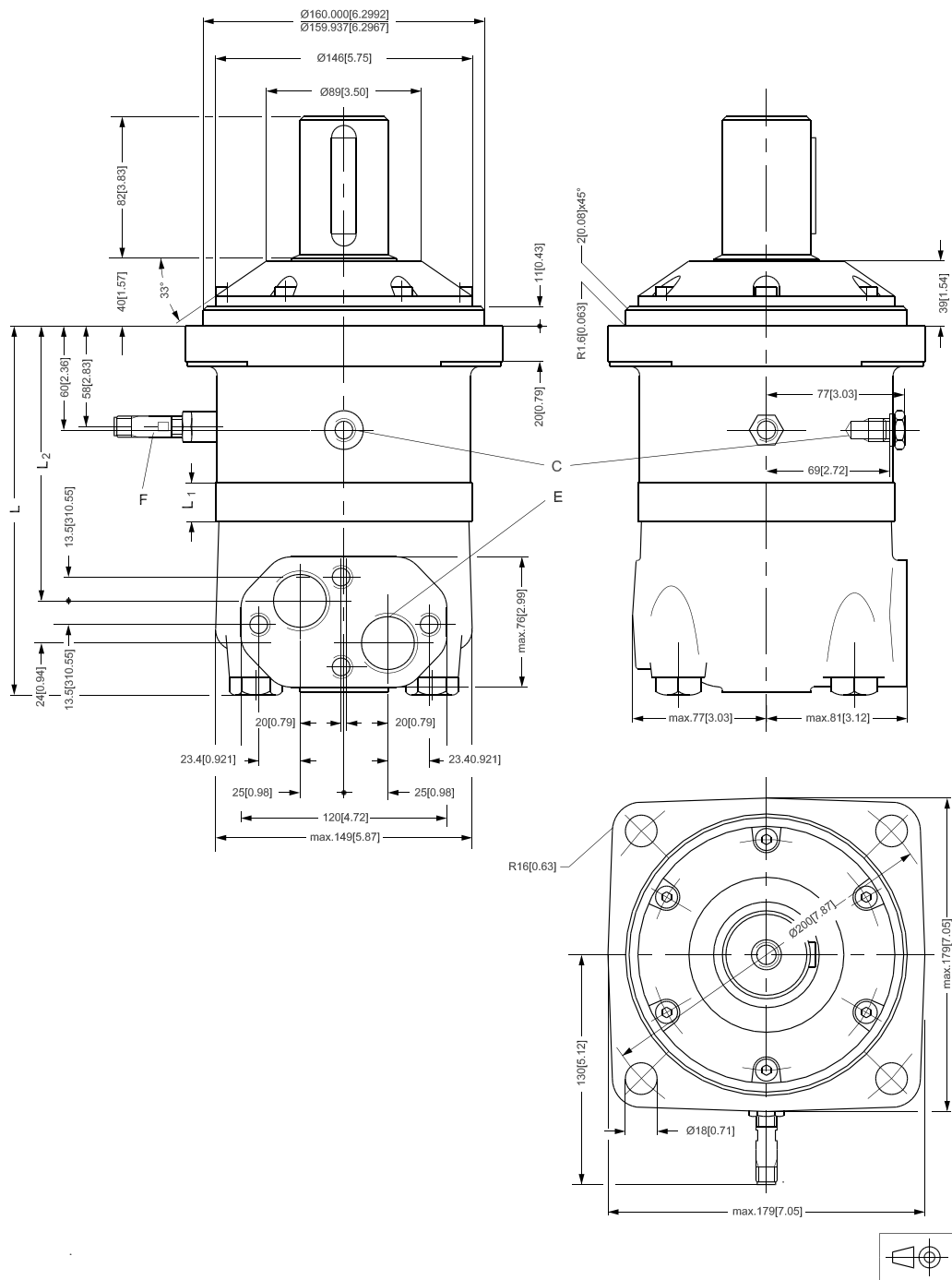

C: Drain connection G 1/4 ; 12 mm [0.47 in] deep

D: M12; 12 mm [0.47 in] deep

E: G 1; 18 mm [0.71 in] deep

F : Plug connection: Binder Series 713



159G19.10

Dimensions - European Version

Type	Lmax mm [in]	L1 mm [in]	L2 mm [in]
OMV 315 EM	215 [8.46]	22.0 [0.87]	160 [6.30]
OMV 400 EM	222 [8.74]	29.0[1.14]	167 [6.57]
OMV 500 EM	230 [9.05]	37.0 [1.46]	175 [6.89]
OMV 630 EM	240 [9.45]	47.5 [1.87]	186 [7.32]
OMV 800 EM	254 [10.00]	61.5 [2.42]	200 [7.87]

*) The gearwheel set is 3.5 mm [0.138 in] wider across the rollers than the L1 dimensions

Technical Information Orbital Motors with Speed Sensor

Weight of Motors
Weight of Motors OMM,OMP and OMR

Code no.	Weight	
	kg	[lb]
151-5390	5.7	[12.57]
151-5391	5.7	[12.57]
151-5392	5.8	[12.79]
151-5393	6.0	[13.23]
151-5395	6.3	[13.89]
151-5396	6.5	[14.33]
151-5397	6.7	[14.77]
151-5398	7.0	[15.43]
151-5399	7.5	[16.53]
151-6391	6.8	[14.99]
151-6392	7.0	[15.43]
151-6393	7.1	[15.65]
151-6394	7.3	[16.09]
151-6395	7.6	[16.75]
151-6396	8.1	[17.86]
151-6397	8.6	[18.96]
151-6398	9.1	[20.06]
151-6399	9.6	[21.16]
151-6873	6.1	[13.45]
151-6874	5.7	[12.57]
151-6878	5.8	[12.79]
151-6879	5.9	[13.01]
151-6880	6.4	[14.11]
151-6881	6.6	[14.55]
151-6882	6.8	[14.99]
151-6883	7.1	[15.65]
151-6884	7.6	[16.75]
151-6885	6.9	[15.21]
151-6886	7.1	[15.65]
151-6887	7.2	[15.87]
151-6888	7.4	[16.31]
151-6889	7.7	[16.97]
151-6890	8.7	[19.18]
151-6891	9.2	[20.28]
151-6892	9.7	[21.38]
151-6896	8.2	[18.08]

Technical Information Orbital Motors with Speed Sensor

Weight of Motors

Code no.	Weight	
	kg	[lb]
151G5040	2.0	[4.41]
151G5041	2.1	[4.63]
151G5042	2.2	[4.85]
151G5043	2.3	[5.07]
151G5044	2.5	[5.51]
151G5045	2.0	[4.41]
151G5046	2.1	[4.63]
151G5047	2.2	[4.85]
151G5048	2.3	[5.07]
151G5049	2.5	[5.51]

Weight of Motors OMS, OMT and OMV

Code no.	Weight	
	kg	[lb]
151F3020	9.9	[21.82]
151F3021	10.1	[22.27]
151F3022	10.4	[22.93]
151F3023	10.7	[23.59]
151F3024	11.1	[24.47]
151F3025	11.7	[25.79]
151F3026	12.4	[27.34]
151F3027	13.2	[29.10]
151F3051	10.0	[22.05]
151F3052	10.2	[22.49]
151F3053	10.5	[23.15]
151F3054	10.8	[23.81]
151F3055	11.2	[24.69]
151F3056	11.8	[26.01]
151F3057	12.5	[27.56]
151F3058	13.3	[29.32]
151F3059	13.3	[29.32]
151F3064	10.5	[23.15]
151F3065	10.7	[23.59]
151F3066	11.0	[24.25]
151F3067	11.4	[25.13]
151F3068	11.8	[26.01]
151F3069	12.3	[27.12]
151F3070	13.0	[28.66]
151F3071	13.8	[30.42]
151F3072	13.8	[30.42]
151B3260	20.1	[44.31]

Weight of Motors

Code no.	Weight	
	kg	[lb]
151B3262	21.1	[44.31]
151B3263	22.1	[40.72]
151B3264	23.1	[50.93]
151B3265	24.1	[53.13]
151B3266	31.9	[70.33]
151B3260	32.7	[72.09]
151B3261	20.6	[45.42]
151B3268	33.6	[74.07]
151B3269	35.0	[77.16]
151B3270	36.6	[80.69]
151B3700	20.2	[44.53]
151B3701	20.7	[45.64]
151B3702	21.2	[46.74]
151B3703	22.2	[48.94]
151B3704	23.2	[51.15]
151B3705	24.2	[53.35]



Products we offer:

- Bent Axis Motors
- Closed Circuit Axial Piston Pumps and Motors
- Displays
- Electrohydraulic Power Steering
- Electrohydraulics
- Hydraulic Power Steering
- Integrated Systems
- Joysticks and Control Handles
- Microcontrollers and Software
- Open Circuit Axial Piston Pumps
- Orbital Motors
- PLUS+1® GUIDE
- Proportional Valves
- Sensors
- Steering
- Transit Mixer Drives

Danfoss Power Solutions is a global manufacturer and supplier of high-quality hydraulic and electronic components. We specialize in providing state-of-the-art technology and solutions that excel in the harsh operating conditions of the mobile off-highway market. Building on our extensive applications expertise, we work closely with our customers to ensure exceptional performance for a broad range of off-highway vehicles.

We help OEMs around the world speed up system development, reduce costs and bring vehicles to market faster.

Danfoss – Your Strongest Partner in Mobile Hydraulics.

Go to www.powersolutions.danfoss.com for further product information.

Wherever off-highway vehicles are at work, so is Danfoss. We offer expert worldwide support for our customers, ensuring the best possible solutions for outstanding performance. And with an extensive network of Global Service Partners, we also provide comprehensive global service for all of our components.

Please contact the Danfoss Power Solution representative nearest you.

Comatrol

www.comatrol.com

Schwarzmueller-Inverter

www.schwarzmueller-inverter.com

Turolla

www.turollaocg.com

Hydro-Gear

www.hydro-gear.com

Daikin-Sauer-Danfoss

www.daikin-sauer-danfoss.com

Local address:

Danfoss Power Solutions (US) Company
2800 East 13th Street
Ames, IA 50010, USA
Phone: +1 515 239 6000

Danfoss Power Solutions GmbH & Co. OHG
Krokamp 35
D-24539 Neumünster, Germany
Phone: +49 4321 871 0

Danfoss Power Solutions ApS
Nordborgvej 81
DK-6430 Nordborg, Denmark
Phone: +45 7488 2222

Danfoss Power Solutions Trading (Shanghai) Co., Ltd.
Building #22, No. 1000 Jin Hai Rd
Jin Qiao, Pudong New District
Shanghai, China 201206
Phone: +86 21 3418 5200

Danfoss can accept no responsibility for possible errors in catalogues, brochures and other printed material. Danfoss reserves the right to alter its products without notice. This also applies to products already on order provided that such alterations can be made without changes being necessary in specifications already agreed. All trademarks in this material are property of the respective companies. Danfoss and the Danfoss logotype are trademarks of Danfoss A/S. All rights reserved.