

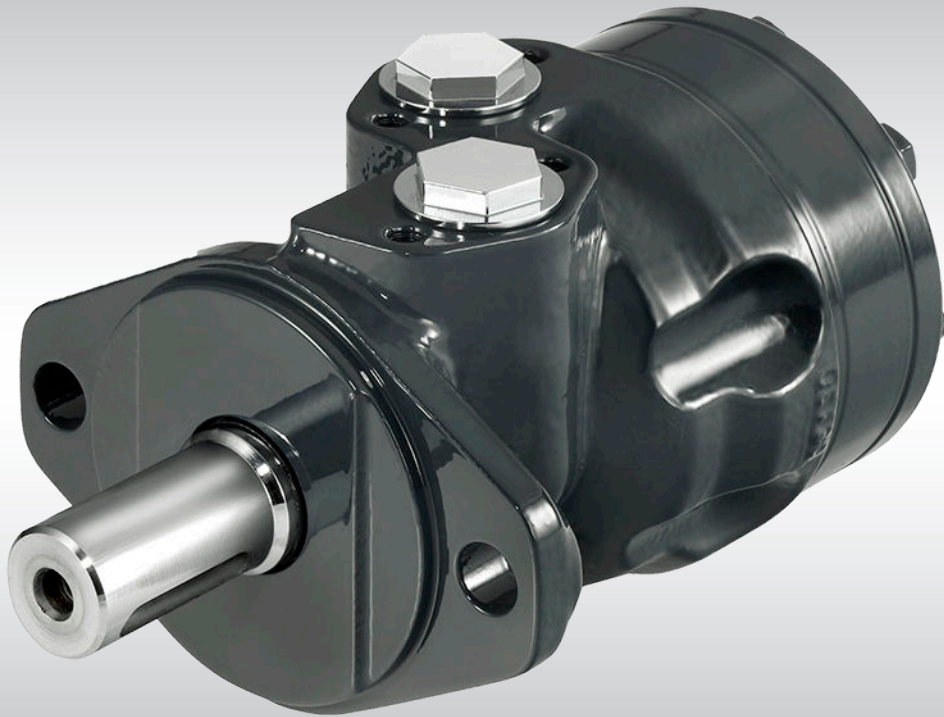

Technical Information
Orbital Motor
VMR Series 2



Revision history*Table of revisions*

Date	Changed	Rev
January 2016	Technical data corrected	0304
May 2014	Code number changed	CC
Mar 2014	Minor updates	CB
Feb 2014	Dimensions drawings updated	CA
Feb 2014	Dimensions drawings updated	BA
Feb 2014	First version - DITA CMS	AA

Contents
A wide range of Orbital Motors

Characteristic, features and application areas of Orbital Motors.....	4
Characteristic features of Danfoss Orbital Motors.....	4
Technical features of Danfoss Orbital Motor.....	4
The Danfoss Orbital Motors are used in the following application areas:.....	5
Survey of literature with technical data on Danfoss Orbital Motors.....	5

Data survey

Introduction.....	6
VMR features.....	6

Speed, torque and output

Speed, torque and output.....	7
-------------------------------	---

Versions

Versions and code numbers.....	8
--------------------------------	---

Technical data

Technical data for VMR.....	9
-----------------------------	---

Shaft seal

VMR with High Pressure Shaft Seal (HPS).....	10
--	----

Pressure drop

Pressure drop in motor.....	11
-----------------------------	----

Oil flow

Oil flow in drain line.....	12
Direction of shaft rotation.....	12

Shaft load

Permissible shaft load.....	13
-----------------------------	----

Shaft

Shaft version.....	14
--------------------	----

Port

Port thread versions.....	16
Manifold mount VMR.....	16

Dimensions, VMR European version, cyl. 25 mm shaft, A2 flange and side ports

VMR European version, cyl. 25 mm shaft, A2 flange.....	17
--	----

Dimensions, VMR, cyl. 1 inch version, A2 flange and side ports

VMR, cyl. 1 inch version, A2 flange.....	19
--	----

Dimensions, VMR SAE version, 1 inch splined shaft, A2 flange and side ports

VMR SAE version, 1 inch splined shaft, A2 flange.....	21
---	----

Dimensions, VMR SAE version, cyl. 1 inch shaft, Woodruff key, A2 flange and side ports

VMR SAE version, cyl. 1 inch shaft, Woodruff key, A2 flange.....	23
--	----

Dimensions, VMR SAE version, 1 inch splined shaft, C flange and side ports

VMR SAE version, 1 inch splined shaft, C flange.....	25
--	----

Dimensions, VMR SAE version, cyl. 1 inch shaft, Woodruff key, C flange and side ports

VMR SAE version, cyl. 1 inch shaft, Woodruff key, C flange.....	27
---	----

A wide range of Orbital Motors

Characteristic, features and application areas of Orbital Motors

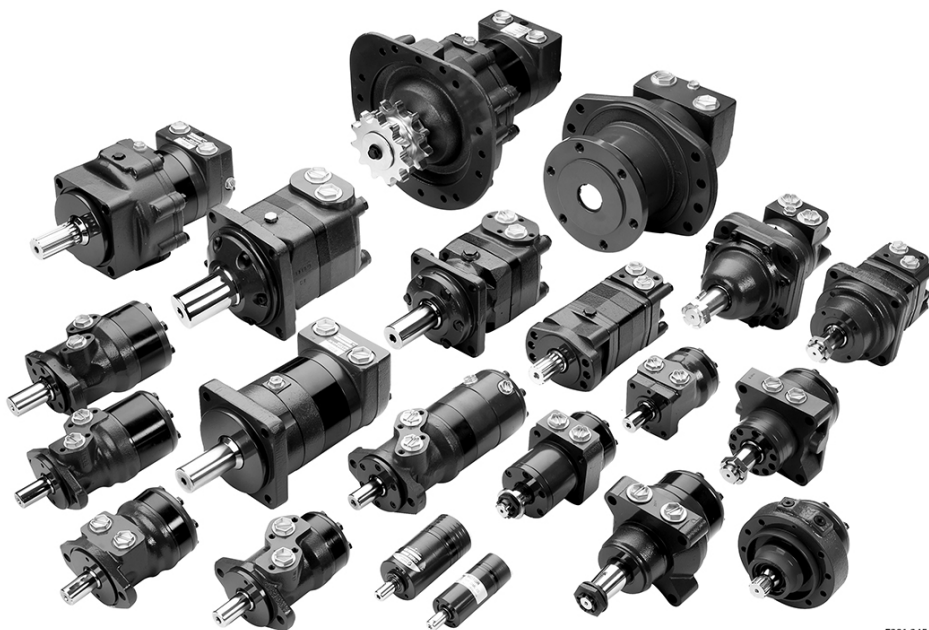

Danfoss is a world leader within production of low speed orbital motors with high torque. We can offer more than 3,000 different orbital motors, categorised in types, variants and sizes (including different shaft versions).

The motors vary in size (rated displacement) from 8 cm³ [0.50 in³] to 800 cm³ [48.9 in³] per revolution.

Speeds range up to approximate 2,500 min⁻¹ (rpm) for the smallest type and up to approximate 600 min⁻¹ (rpm) for the largest type.

Maximum operating torques vary from 13 N·m [115 lbf·in] to 2,700 N·m [24,000 lbf·in] (peak) and maximum outputs are from 2.0 kW [2.7 hp] to 70 kW [95 hp].

Characteristic features of Danfoss Orbital Motors

- Smooth running over the entire speed range
- Constant operating torque over a wide speed range
- High starting torque
- High return pressure without the use of drain line (High pressure shaft seal)
- High efficiency
- Long life under extreme operating conditions
- Robust and compact design
- High radial and axial bearing capacity
- For applications in both open and closed loop hydraulic systems
- Suitable for a wide variety of hydraulics fluids

Technical features of Danfoss Orbital Motor

The programme is characterised by technical features appealing to a large number of applications and a part of the programme is characterised by motors that can be adapted to a given application. Adaptions comprise the following variants among others:

A wide range of Orbital Motors

- Motors with corrosion resistant parts
- Wheel motors with recessed mounting flange
- OMP, OMR- motors with needle bearing
- OMR motor in low leakage version
- OMR motors in a super low leakage version
- Short motors without bearings
- Ultra short motors
- Motors with integrated positive holding brake
- Motors with integrated negative holding brake
- Motors with integrated flushing valve
- Motors with speed sensor
- Motors with tacho connection
- All motors are available with black finish paint

The Danfoss Orbital Motors are used in the following application areas:

- Construction equipment
- Agricultural equipment
- Material handling & Lifting equipment
- Forestry equipment
- Lawn and turf equipment
- Special purpose
- Machine tools and stationary equipment
- Marine equipment

Survey of literature with technical data on Danfoss Orbital Motors

Detailed data on all Danfoss Orbital Motors can be found in our motor catalogue, which is divided into more individual subcatalogues:

- General information on Danfoss Orbital Motors: function, use, selection of orbital motor, hydraulic systems, etc.
- Technical data on small motors: OML and OMM
- Technical data on medium sized motors: OMP, OMR, OMH
- Technical data on medium sized motors: DH and DS
- Technical data on medium sized motors: OMEW
- Technical data on medium sized motors: VMP
- Technical data on medium sized motors: VMR
- Technical data on large motors: OMS, OMT and OMV
- Technical data on large motors: TMK
- Technical data on large motors: TMT
- Technical data on large motors: TMTHW
- Technical data on large motors: TMVW

A general survey brochure on Danfoss Orbital Motors gives a quick motor reference based on power, torque, speed and capabilities.

Data survey

Introduction

By introducing the VMR, Danfoss is introducing an Orbital Motor in the new V-Series. In order to meet the demands for motors that have the right duty cycle and efficiency capabilities for a given function, Danfoss now has 3 Orbital Motor Series:

T-Series – The Highest Torque

Leading performance with a long lifetime makes light work of the heaviest duties. Offering pressure capability up to 350 bar [5076 psi] and high starting torque, the T-Series is the energy-efficient choice for the toughest working environments.

O-Series – The Flexible Choice

The O-Series is flexible beyond compare. Delivering premium power across the board, these motors cover small to large, medium to heavy-duty needs with pressure capability up to 275 bar [3990 psi]. Robust, reliable and designed to fulfill the latest emissions standards.

V-Series – The Core Solution

The V-Series is your quality benchmark in the medium duty market. Based on proven technology, these reliable motors will reduce your overall system costs while adding value to your machine. Perfect for many tasks.

VMR features

- High pressure shaft seal
- Proven orbital motor design
- 3-chamber motor design
- Suitable for medium and low duty

Speed, torque and output

Speed, torque and output

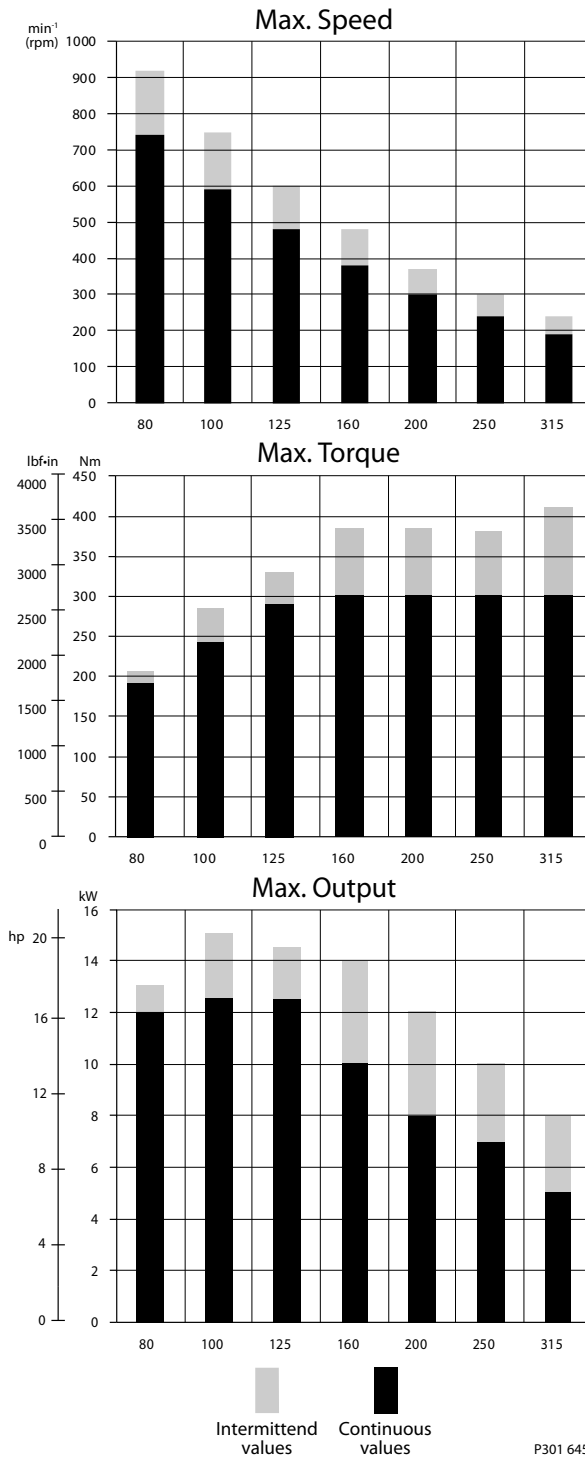

Technical Information VMR Series 2 Orbital Motor
Versions
Versions and code numbers
Versions

Mounting flange	2 hole oval flange (A2 - flange)						Square flange (C-flange)		
Spigot diameter	Ø82.5 mm [3.25 in]						Ø44.4 mm [1.75 in]		
Bolt circle diameter (BC)	Ø106.4 mm [4.20 in]						Ø82.5 mm [3.25 in]		
Shaft	Cyl 25 mm, Parallel key DIN 6885		Cyl. 1 in, Parallel key BS 46		Splined, 1 in, SAE 6B	Cyl. 1 in, woodruff key		Splined 1 in, SAE 6B	Cyl. 1 in, woodruff key
Thread in shaft	M8 18 [0.71] deep		M8 18 [0.71] deep		1/4-20 UNC 14 [0.55] deep	1/4-20 UNC 14 [0.55] deep		1/4-20 UNC 14 [0.55] deep	1/4-20 UNC 14 [0.55] deep
Port size	G1/2		7/8-14 UNF		7/8-14 UNF	7/8-14 UNF		7/8-14 UNF	7/8-14 UNF
Drain port	G1/4	G1/4	7/16-20 UNF	7/16-20 UNF	7/16-20 UNF	7/16-20 UNF		7/16-20 UNF	7/16-20 UNF
European version	x	x							
US version			x	x	x	x		x	x
Check valve	x	x	x	x	x	x		x	x
Painted Black		x		x					
Code numbers									
VMR 80	11174302	11174273	11174314	11174321	11174329	11174445	11174471	11174344	
VMR 100	11174303	11174274	11174315	11174322	11174330	11174446	11174472	11174345	
VMR 125	11174304	11174275	11174316	11174323	11174331	11174447	11174473	11174346	
VMR 160	11174305	11174276	11174317	11174324	11174332	11174448	11174474	11174347	
VMR 200	11174306	11174277	11174318	11174325	11174333	11174449	11174475	11174348	
VMR 250	11174307	11174278	11174319	11174326	11174334	11174469	11174476	11174349	
VMR 315	11174309	11174279	11174320	11174327	11174335	11174470	11174477	11174350	

Technical Information VMR Series 2 Orbital Motor

Technical data

Technical data for VMR

Technical data for VMR with 25 mm, 1 in cylindrical and 1 in splined shaft

Type Motorsize			VMR 80	VMR 100	VMR 125	VMR 160	VMR 200	VMR 250	VMR 315
Geometric displacement	cm ³ [in ³]		80.3 [4.9]	99.8 [6.1]	124.1 [7.6]	155.4 [9.5]	198.2 [12.1]	248.1 [15.1]	310.1 [18.9]
Max. speed	min ⁻¹ [rpm]	cont.	740	590	480	380	300	240	190
		int. ¹⁾	920	750	600	480	370	300	240
Max. torque	Nm [lbf·in]	cont.	190 [1680]	240 [2125]	290 [2565]	300 [2655]	300 [2655]	300 [2655]	300 [2655]
		int. ¹⁾	205 [1815]	280 [2480]	330 [2920]	385 [3410]	385 [3410]	380 [3365]	410 [3630]
Max. output	kW [hp]	cont.	12 [16]	12.5 [16.8]	12.5 [16.8]	10 [13.4]	8 [10.7]	7 [9.4]	5 [6.7]
		int. ¹⁾	13 [17.4]	15 [20]	14.5 [19.4]	14 [18.8]	12 [16.1]	10 [13.4]	8 [10.7]
Max. pressure drop New VMR	bar [psi]	cont.	175 [2540]	175 [2540]	175 [2540]	140 [2030]	110 [1595]	120 [1740]	70 [1020]
		int. ¹⁾	200 [2900]	200 [2900]	200 [2900]	175 [2395]	140 [2030]	120 [1740]	100 [1450]
Max. oil flow	l/min [US gal/min]	cont.	60 [15.9]	60 [15.9]	60 [15.9]	60 [15.9]	60 [15.9]	60 [15.9]	60 [15.9]
		int. ¹⁾	75 [19.8]	75 [19.8]	75 [19.8]	75 [19.8]	75 [19.8]	75 [19.8]	75 [19.8]
Max. starting pressure with unloaded shaft	bar [psi]		10 [145]	10 [145]	10 [145]	10 [145]	10 [145]	7 [100]	7 [100]
Min starting torque	at max. Press-drop Nm [lbf·in]	cont.	145 [1285]	195 [1725]	245 [2170]	255 [2255]	295 [2610]	320 [2830]	360 [2830]
		int. ¹⁾	165 [1460]	225 [1990]	275 [2435]	320 [2830]	365 [3230]	410 [3630]	425 [3760]

Type			Max inlet pressure	Max inlet pressure with drain line
VMR 80-315	bar [psi]	cont.	175 [2540]	175 [2540]
		int. ¹⁾	200 [2900]	200 [2900]

1) Intermittent operation: the permissible values may occur for max. 10% of every minute.

Recommendation:

To assure best motor performance, run motor for approximately one hour at 30% of rated pressure before running at full load.

Shaft seal

VMR with High Pressure Shaft Seal (HPS)

VMR with check valves and drain connection: The shaft seal pressure equals the pressure in the drain line.

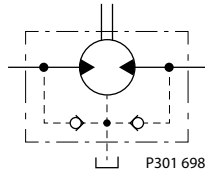

VMR with check valves and *without* drain connected: The shaft seal pressure equals the pressure in the return line + 10 bar [145 psi].

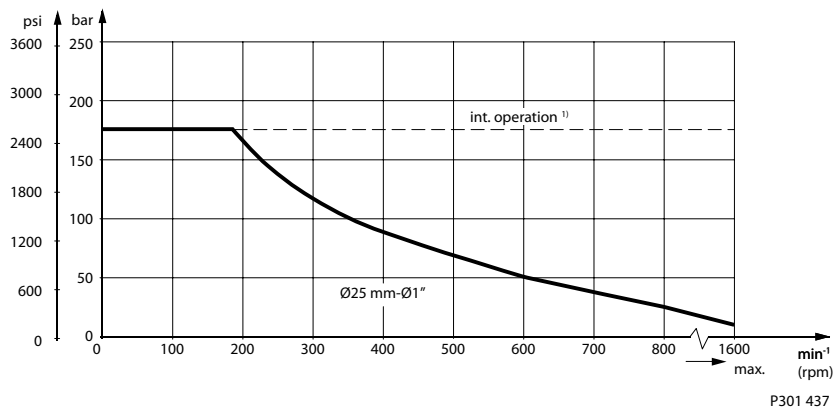
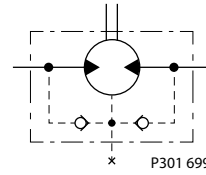

Please check motor pressure according to data under [Technical data for VMR](#).

Pressure drop

Pressure drop in motor

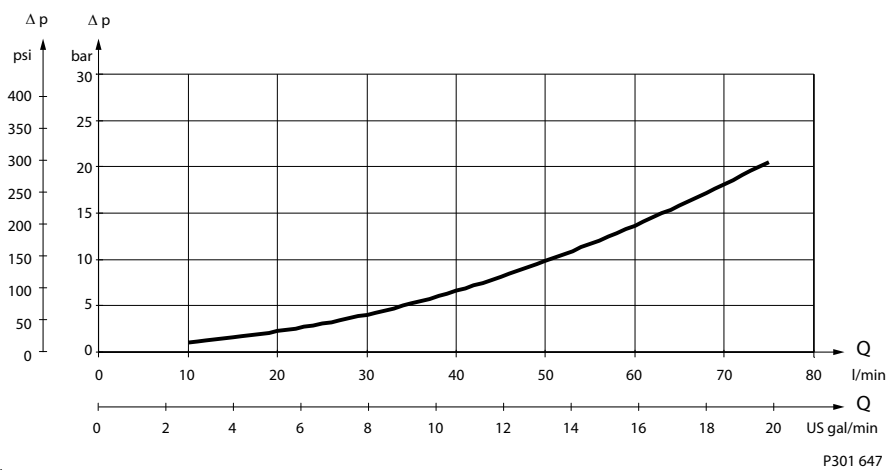

The curve applies to an unloaded motor shaft and an oil viscosity of 35 mm²/s [165 SUS]

Technical Information VMR Series 2 Orbital Motor

Oil flow
Oil flow in drain line

The table shows the max. oil flow in the drain line at a return pressure less than 5-10 bar [75-150 psi].

Pressure drop bar [psi]	Viscosity mm ² /s [SUS]	Oil flow in drain line l/min [US gal/min]
100 [1450]	20 [100]	2.5 [0.66]
	35 [165]	1.8 [0.78]
140 [2030]	20 [100]	3.5 [0.93]
	35 [165]	2.8 [0.74]

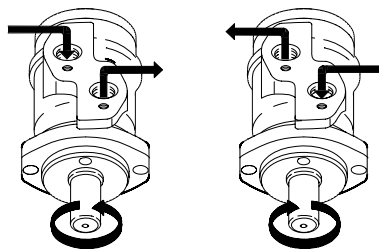
Direction of shaft rotation

151-1836.10 L

Shaft load
Permissible shaft load

The permissible radial shaft load (P_R) depends on

- n = Speed (min^{-1})
- L = Distance from the point of load to the mounting flange (mm, in)

	A2-flange	C-flange
Permissible shaft load (P_R) - L in mm	$\frac{800}{n} \cdot \frac{150000 \text{ N}^*}{100 + L}$	$\frac{800}{n} \cdot \frac{150000 \text{ N}^*}{103 + L}$
Permissible shaft load (P_R) - L in inch	$\frac{800}{n} \cdot \frac{1330 \text{ lbf}^*}{3.94 + L}$	$\frac{800}{n} \cdot \frac{1330 \text{ lbf}^*}{4.06 + L}$

* $n \geq 200 \text{ min}^{-1}$ [rpm]; $L \leq 55 \text{ mm}$ [2.2 in]

$n < 200 \text{ min}^{-1}$ [rpm]; $= > P_{R\text{max}} = 4615 \text{ N}$ [1037 lbf]

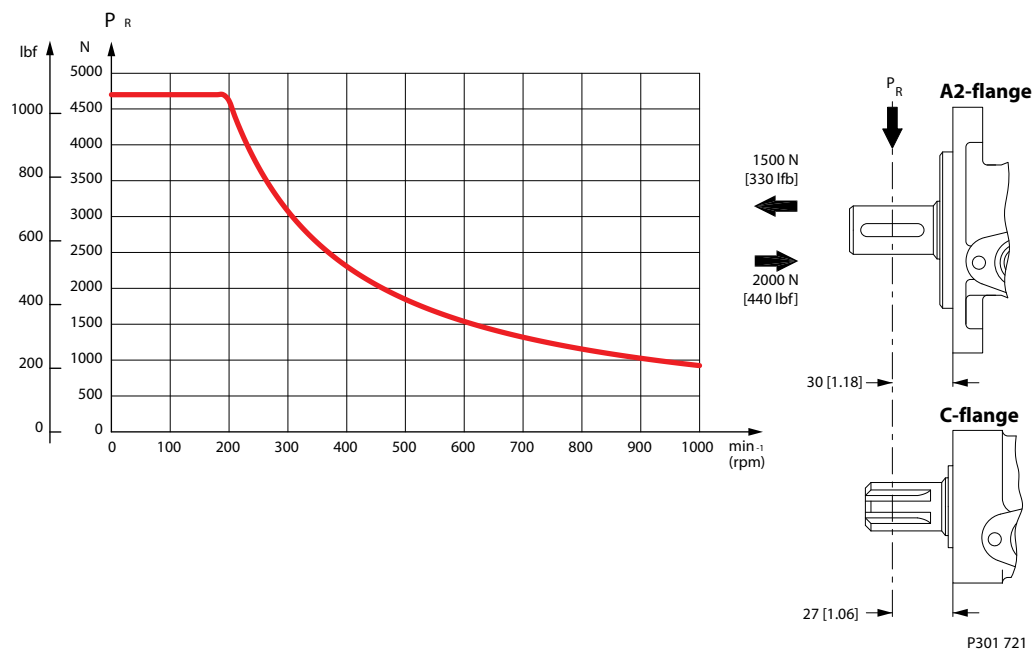

Shaft

Shaft version

EU version

A: Cylindrical shaft
25 mm
D: Parallel key
A 8 x 7 x 32
DIN 6885

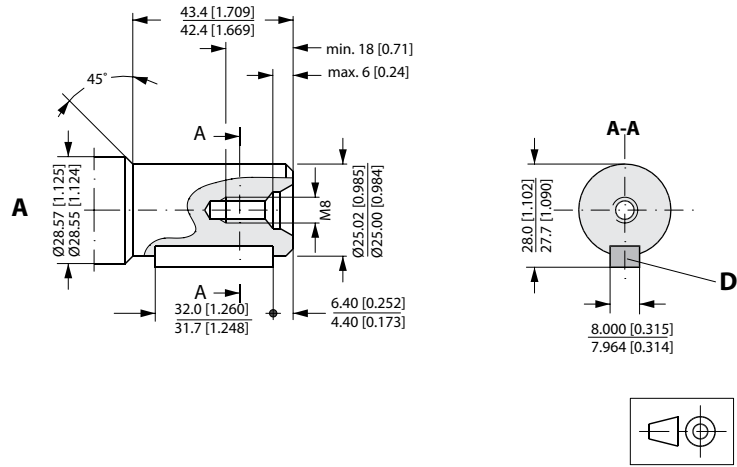

P301 667

EU version

B: Cylindrical shaft
1 in
E: Parallel key
1/4 x 1/4 x 1 1/4 in
B.S. 46

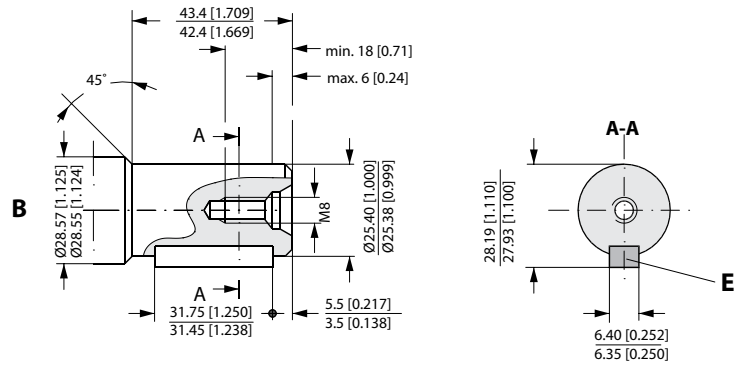

P301 668

US version

A: Cylindrical shaft
1 in
F: Woodruff key
1/4 x 1 in
SAE J502

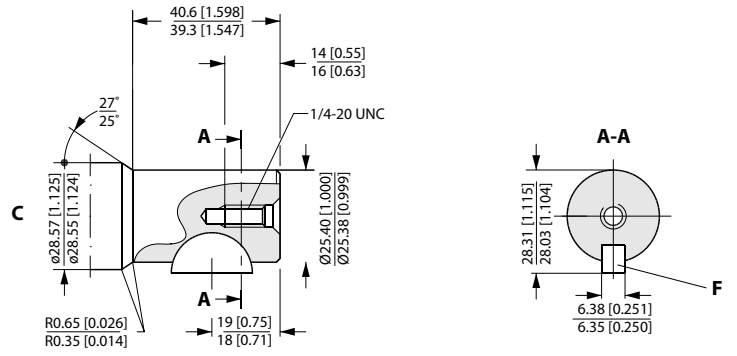

P301 669

Shaft

US version
 G: Splined shaft
 1 in
 SAE 6B
 * Deviates from B.S. 2059
 (SAE 6B)

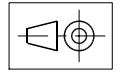
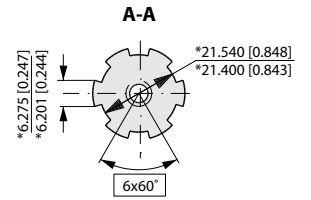
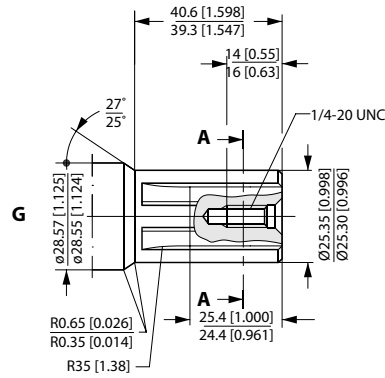

P301 670

Port

Port thread versions

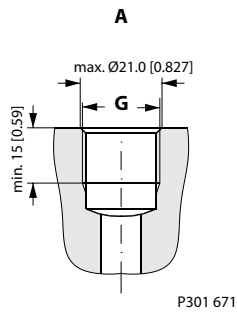

A: G main ports
G: ISO 228/1 - G1/2

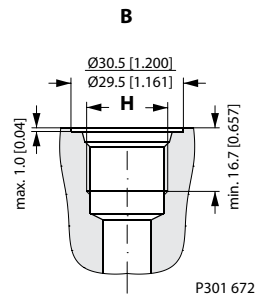

B: UNF main ports
H: 7/8 - 14 UNF O-ring boss port

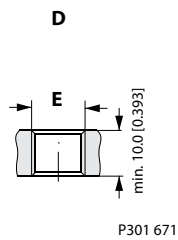

D: G drain port
E: ISO 228/1 - G1/4

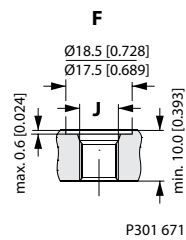

F: UNF drain port
J: 7/16 - 20 UNF O-ring boss port

Manifold mount VMR

European version

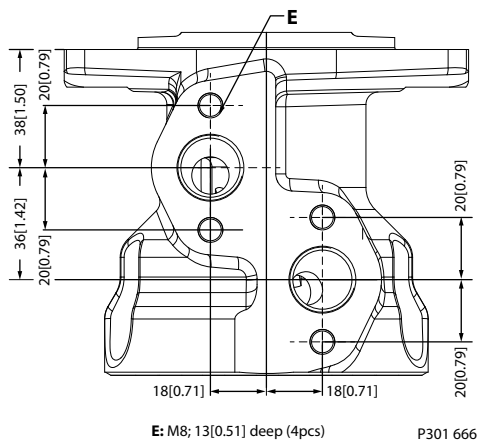

Dimensions, VMR European version, cyl. 25 mm shaft, A2 flange and side ports

VMR European version, cyl. 25 mm shaft, A2 flange

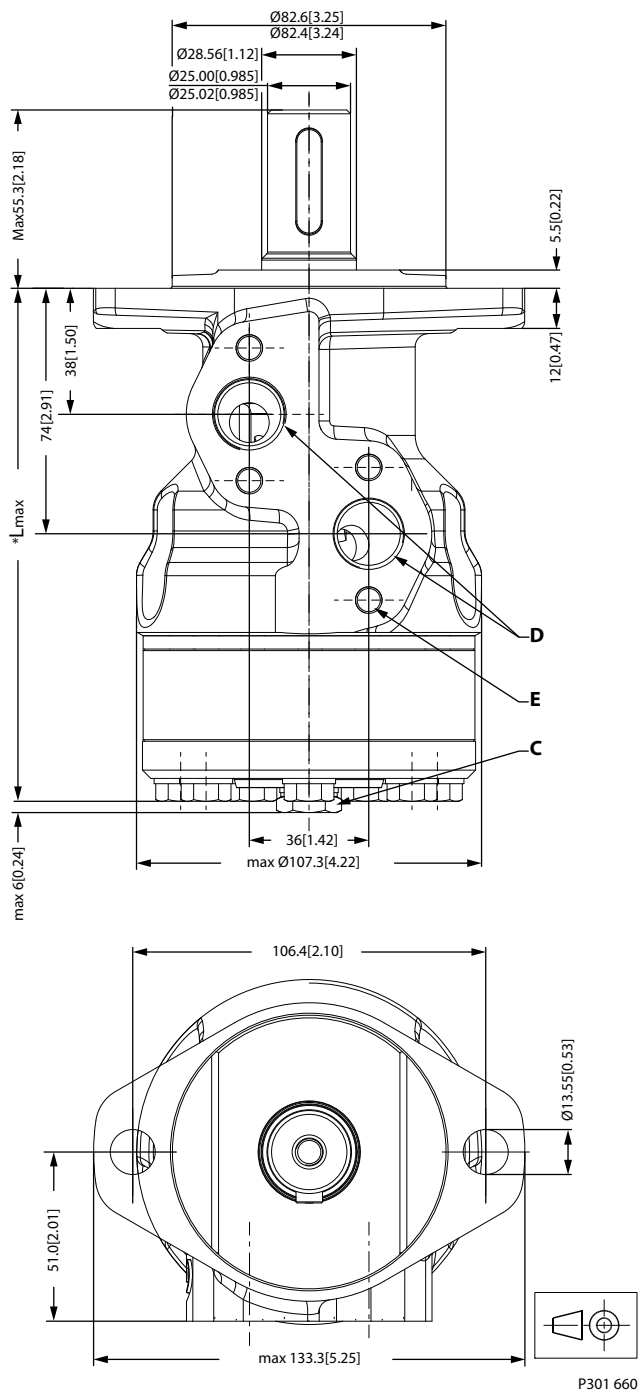

C: Drain connection G1/4; Min. 10 [0.39] deep

D: G1/2; Min 15 [0.59] deep

E: M8; 13 [0.51] deep (4 pcs)

Dimensions, VMR European version, cyl. 25 mm shaft, A2 flange and side ports**Weight and dimensions**

Type	*L _{max} mm [in]	Weight kg [lb]
VMR 80	max 143.1 [5.63]	6.3 [13.89]
VMR 100	max 143.1 [5.63]	6.3 [13.89]
VMR 125	max 146.7 [5.76]	6.4 [14.11]
VMR 160	max 150.9 [5.94]	6.7 [14.77]
VMR 200	max 156.9 [6.18]	6.9 [15.21]
VMR 250	max 163.9 [6.45]	7.3 [16.09]
VMR 315	max 172.6 [6.80]	7.7 [16.98]

Dimensions, VMR, cyl. 1 inch version, A2 flange and side ports

VMR, cyl. 1 inch version, A2 flange

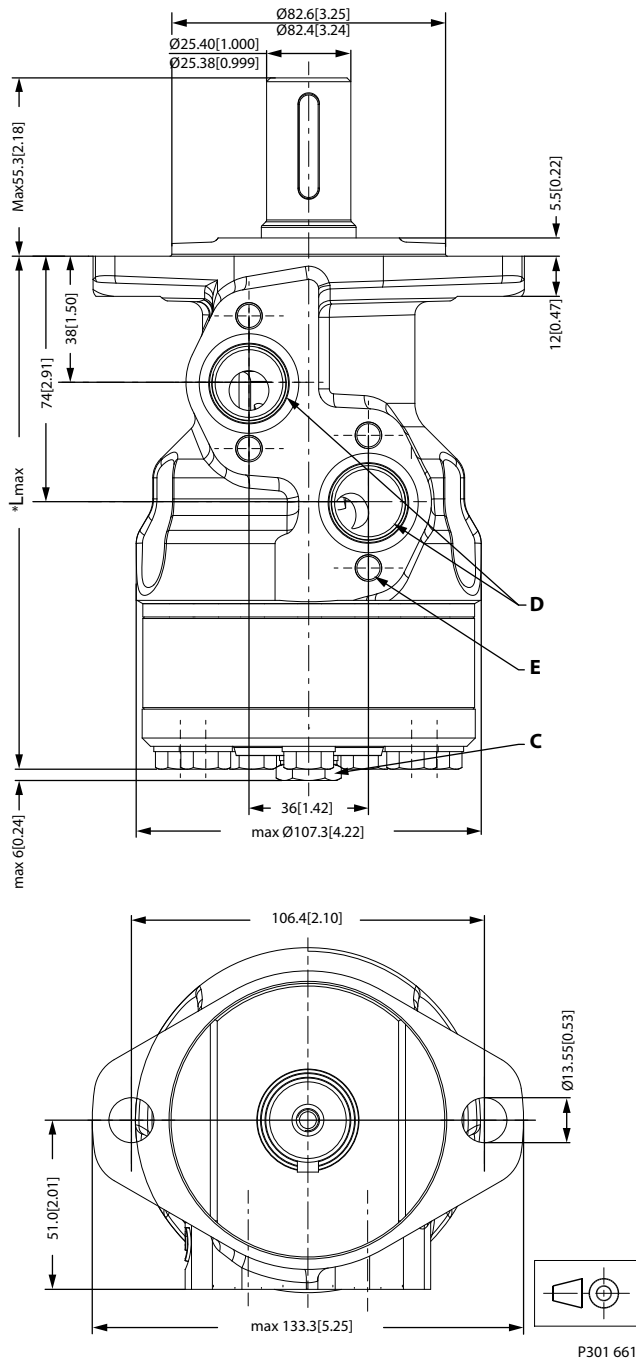

C: Drain connection 7/16-20 UNF; Min. 10 [0.39] deep

D: Port connection 7/8-14 UNF; 16.7 [0.66] deep

E: M8; 13 [0.51] deep (4 pcs)

Dimensions, VMR, cyl. 1 inch version, A2 flange and side ports**Weight and dimensions**

Type	*L _{max} mm [in]	Weight kg [lg]
VMR 80	max 143.1 [5.63]	6.3 [13.89]
VMR 100	max 143.1 [5.63]	6.3 [13.89]
VMR 125	max 146.7 [5.76]	6.4 [14.11]
VMR 160	max 150.9 [5.94]	6.7 [14.77]
VMR 200	max 156.9 [6.18]	6.9 [15.21]
VMR 250	max 163.9 [6.45]	7.3 [16.09]
VMR 315	max 172.6 [6.80]	7.7 [16.98]

Dimensions, VMR SAE version, 1 inch splined shaft, A2 flange and side ports

VMR SAE version, 1 inch splined shaft, A2 flange

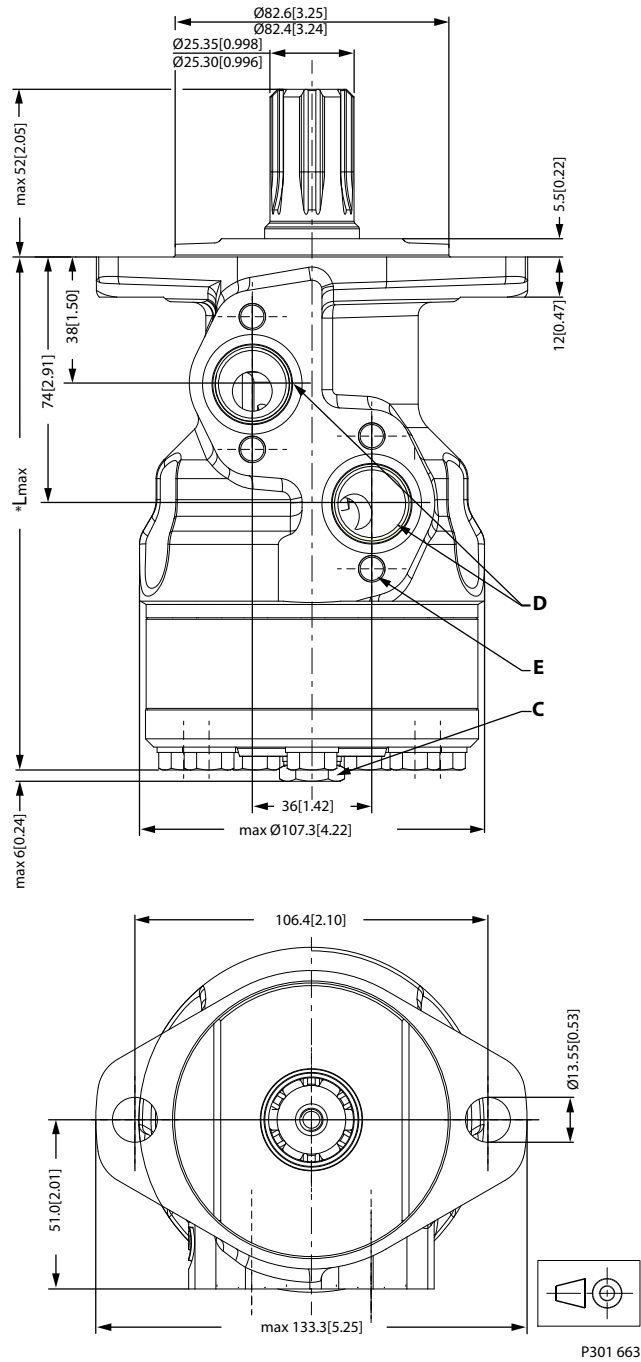

C: Drain connection 7/16-20 UNF; Min. 10 [0.39] deep

D: Port connection 7/8-14 UNF; 16.7 [0.66] deep

E: M8; 13 [0.51] deep (4 pcs)

Dimensions, VMR SAE version, 1 inch splined shaft, A2 flange and side ports**Weight and dimensions**

Type	*L _{max} mm [in]	Weight kg [lb]
VMR 80	max 143.1 [5.63]	6.3 [13.89]
VMR 100	max 143.1 [5.63]	6.3 [13.89]
VMR 125	max 146.7 [5.76]	6.4 [14.11]
VMR 160	max 150.9 [5.94]	6.7 [14.77]
VMR 200	max 156.9 [6.18]	6.9 [15.21]
VMR 250	max 163.9 [6.45]	7.3 [16.09]
VMR 315	max 172.6 [6.80]	7.7 [16.98]

Dimensions, VMR SAE version, cyl. 1 inch shaft, Woodruff key, A2 flange and side ports

VMR SAE version, cyl. 1 inch shaft, Woodruff key, A2 flange

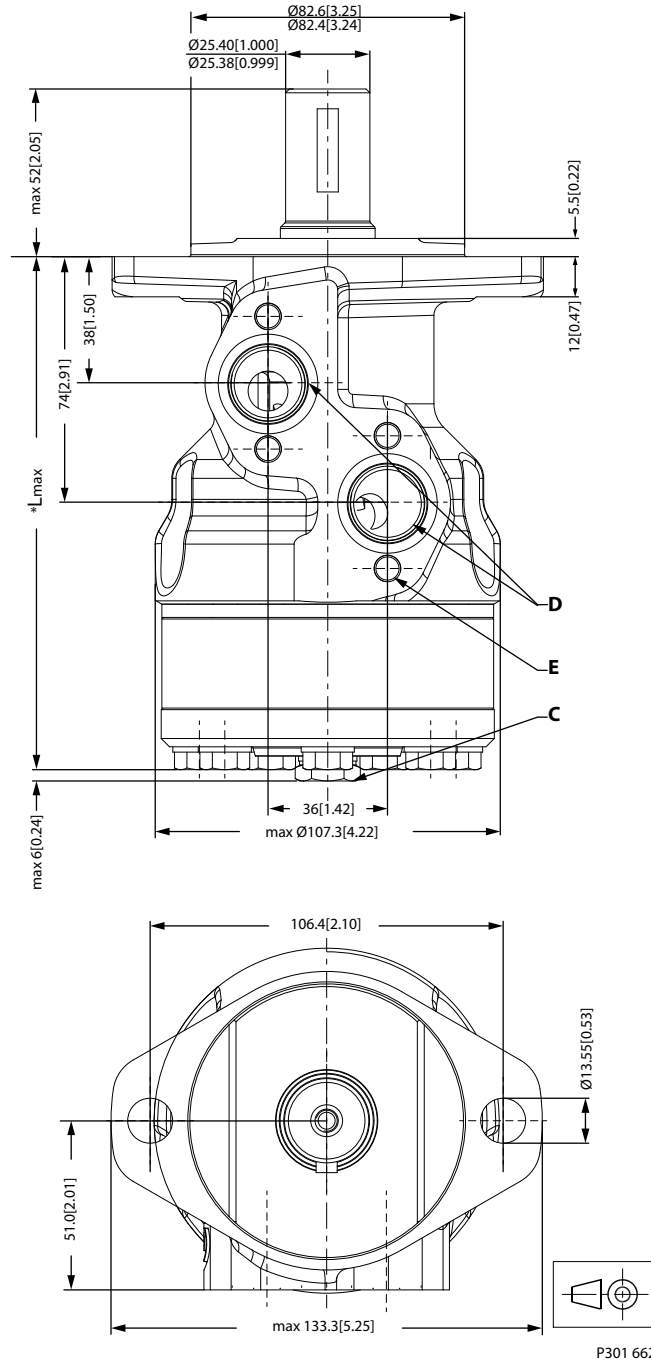

C: Drain connection 7/16-20 UNF; Min. 10 [0.39] deep

D: Port connection 7/8-14 UNF; 16.7 [0.66] deep

E: M8; 13 [0.51] deep (4 pcs)

Dimensions, VMR SAE version, cyl. 1 inch shaft, Woodruff key, A2 flange and side ports

Weight and dimensions

Type	*L _{max} mm [in]	Weight kg [lb]
VMR 80	max 143.1 [5.63]	6.3 [13.98]
VMR 100	max 143.1 [5.63]	6.3 [13.98]
VMR 125	max 146.7 [5.76]	6.4 [14.11]
VMR 160	max 150.9 [5.94]	6.7 [14.77]
VMR 200	max 156.9 [6.18]	6.9 [15.21]
VMR 250	max 163.9 [6.45]	7.3 [16.09]
VMR 315	max 172.6 [6.80]	7.7 [16.98]

Dimensions, VMR SAE version, 1 inch splined shaft, C flange and side ports

VMR SAE version, 1 inch splined shaft, C flange

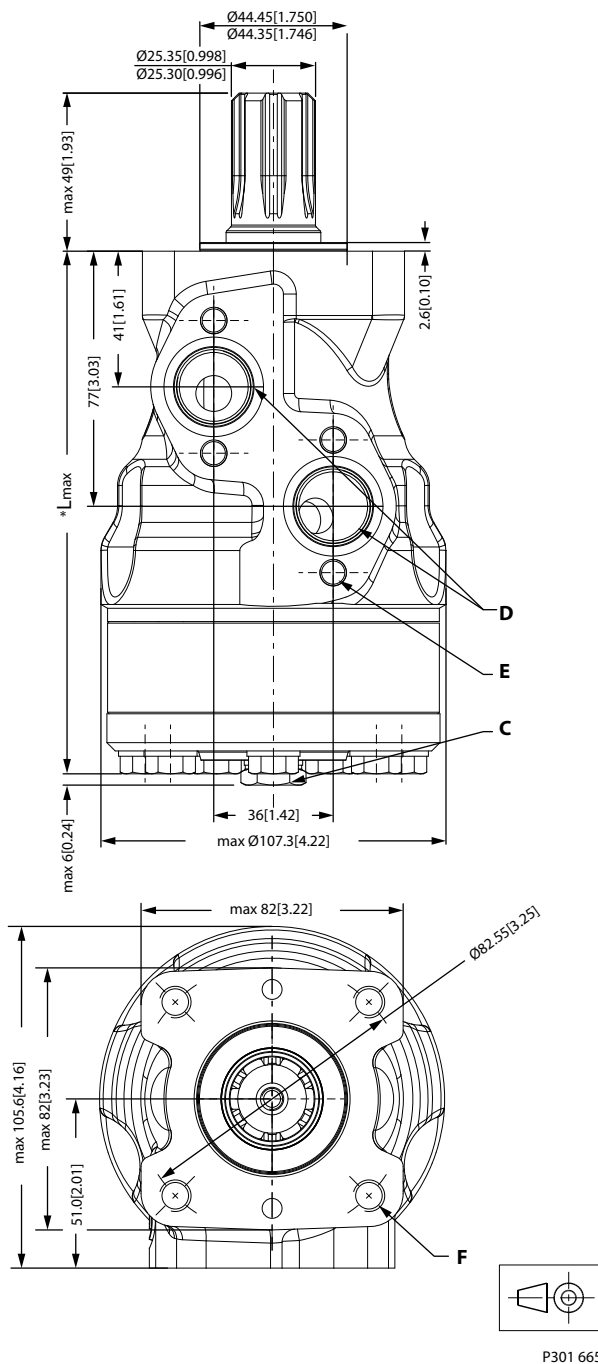

- C: Drain connection 7/16-20 UNF; Min. 10 [0.39] deep
- D: Port connection 7/8-14 UNF; 16.7 [0.66] deep
- E: M8; 13 [0.51] deep (4 pcs)
- F: 3/8-16 UNC 15 [0.59] deep (4 pcs)

Dimensions, VMR SAE version, 1 inch splined shaft, C flange and side ports**Weight and dimensions**

Type	*L _{max} mm [in]	Weight kg [lb]
VMR 80	max 145.6 [5.73]	6.3 [13.89]
VMR 100	max 145.6 [5.73]	6.3 [13.89]
VMR 125	max 149.0 [5.87]	6.4 [14.11]
VMR 160	max 153.4 [6.04]	6.7 [14.77]
VMR 200	max 159.4 [6.28]	6.9 [15.21]
VMR 250	max 166.4 [6.55]	7.3 [16.09]
VMR 315	max 175.1 [6.89]	7.7 [16.98]

Dimensions, VMR SAE version, cyl. 1 inch shaft, Woodruff key, C flange and side ports

VMR SAE version, cyl. 1 inch shaft, Woodruff key, C flange

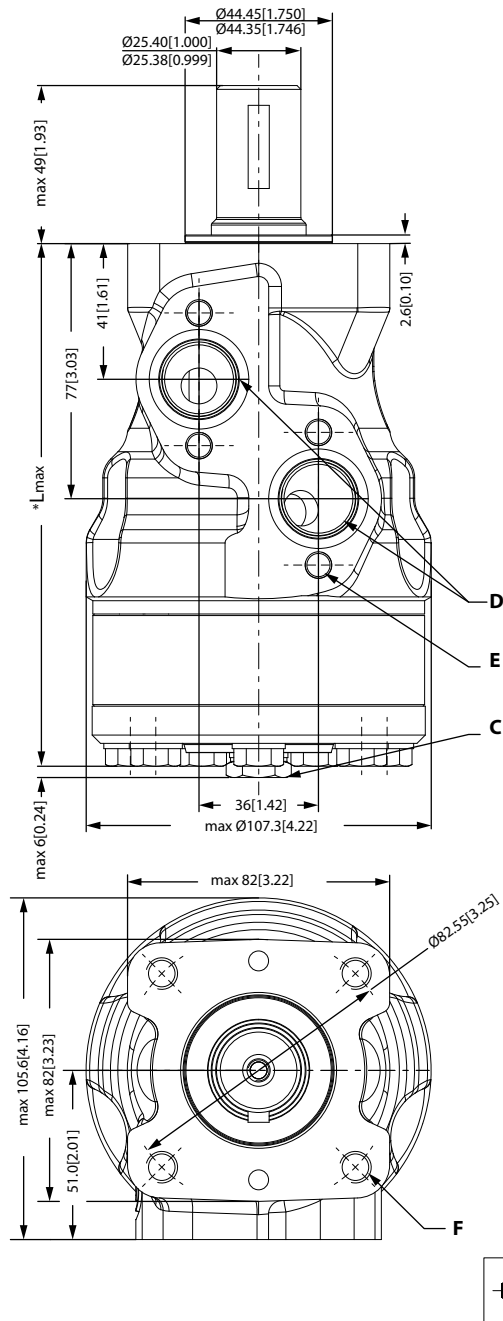

P301 664

- C: Drain connection 7/16-20 UNF; Min. 10 [0.39] deep
- D: Port connection 7/8-14 UNF; 16.7 [0.66] deep
- E: M8; 13 [0.51] deep (4 pcs)
- F: 3/8-16 UNC 15 [0.59] deep (4 pcs)

Dimensions, VMR SAE version, cyl. 1 inch shaft, Woodruff key, C flange and side ports**Weight and dimensions**

Type	*L _{max} mm [in]	Weight kg [lb]
VMR 80	max 145.6 [5.73]	6.3 [13.89]
VMR 100	max 145.6 [5.73]	6.3 [13.89]
VMR 125	max 149.0 [5.87]	6.4 [14.11]
VMR 160	max 153.4 [6.04]	6.7 [14.77]
VMR 200	max 159.4 [6.28]	6.9 [15.21]
VMR 250	max 166.4 [6.55]	7.3 [16.09]
VMR 315	max 175.1 [6.89]	7.7 [16.98]



Products we offer:

- Bent Axis Motors
- Closed Circuit Axial Piston Pumps and Motors
- Displays
- Electrohydraulic Power Steering
- Electrohydraulics
- Hydraulic Power Steering
- Integrated Systems
- Joysticks and Control Handles
- Microcontrollers and Software
- Open Circuit Axial Piston Pumps
- Orbital Motors
- PLUS+1® GUIDE
- Proportional Valves
- Sensors
- Steering
- Transit Mixer Drives

Danfoss Power Solutions is a global manufacturer and supplier of high-quality hydraulic and electronic components. We specialize in providing state-of-the-art technology and solutions that excel in the harsh operating conditions of the mobile off-highway market. Building on our extensive applications expertise, we work closely with our customers to ensure exceptional performance for a broad range of off-highway vehicles.

We help OEMs around the world speed up system development, reduce costs and bring vehicles to market faster.

Danfoss – Your Strongest Partner in Mobile Hydraulics.

Go to www.powersolutions.danfoss.com for further product information.

Wherever off-highway vehicles are at work, so is Danfoss. We offer expert worldwide support for our customers, ensuring the best possible solutions for outstanding performance. And with an extensive network of Global Service Partners, we also provide comprehensive global service for all of our components.

Please contact the Danfoss Power Solution representative nearest you.

Comatrol

www.comatrol.com

Schwarzmueller-Inverter

www.schwarzmueller-inverter.com

Turolla

www.turollaocg.com

Hydro-Gear

www.hydro-gear.com

Daikin-Sauer-Danfoss

www.daikin-sauer-danfoss.com

Local address:

Danfoss Power Solutions (US) Company
2800 East 13th Street
Ames, IA 50010, USA
Phone: +1 515 239 6000

Danfoss Power Solutions GmbH & Co. OHG
Krokamp 35
D-24539 Neumünster, Germany
Phone: +49 4321 871 0

Danfoss Power Solutions ApS
Nordborgvej 81
DK-6430 Nordborg, Denmark
Phone: +45 7488 2222

Danfoss Power Solutions Trading (Shanghai) Co., Ltd.
Building #22, No. 1000 Jin Hai Rd
Jin Qiao, Pudong New District
Shanghai, China 201206
Phone: +86 21 3418 5200

Danfoss can accept no responsibility for possible errors in catalogues, brochures and other printed material. Danfoss reserves the right to alter its products without notice. This also applies to products already on order provided that such alterations can be made without changes being necessary in specifications already agreed. All trademarks in this material are property of the respective companies. Danfoss and the Danfoss logotype are trademarks of Danfoss A/S. All rights reserved.