



PGP 620 Series **PGM 620 Series**

Single and Multiple Cast-Iron pumps and motors

Catalog HY09-620/US



The Parker Hannifin Gear Pump Division Assures:

- Consistent quality
- Technical innovation
- Premier customer service

Worldwide Sales and Service

Parker operates sales and service centers in major industrial areas worldwide. Call 1-800-C-PARKER for more information, or for a synopsis of the Gear Pump Division, contact a Parker representative.

The Gear Pump Division's ability to engineer specialty products for unique applications has kept us at the forefront of technology, and ensured our position as the industry leader. Our success has come from providing a quality product with excellent sales and service support.

We manufacture hydraulic components for a wide range of industries including:

- Construction
- Refuse/dump truck
- Material handling
- Forestry
- Agriculture
- Industrial
- Turf care



WARNING

FAILURE OR IMPROPER SELECTION OR IMPROPER USE OF THE PRODUCTS AND/OR SYSTEMS DESCRIBED HEREIN OR RELATED ITEMS CAN CAUSE DEATH, PERSONAL INJURY AND PROPERTY DAMAGE.

This document and other information from Parker Hannifin Corporation, its subsidiaries and authorized distributors provide product and/or system options for further investigation by users having technical expertise. It is important that you analyze all aspects of your application and review the information concerning the product or system in the current product catalog. Due to the variety of operating conditions and applications for these products or systems, the user, through its own analysis and testing, is solely responsible for making the final selection of the products and systems and assuring that all performance, safety and warning requirements of the application are met.

The products described herein, including without limitation, product features, specifications, designs, availability and pricing, are subject to change by Parker Hannifin Corporation and its subsidiaries at any time without notice.

Offer of Sale

The items described in this document are hereby offered for sale by Parker Hannifin Corporation, its subsidiaries or its authorized distributors. This offer and its acceptance are governed by the provisions stated in the "Offer of Sale".

© Copyright 2003, Parker Hannifin Corporation, All Rights Reserved.

Table of Contents

SERIES 620 CAST IRON:	
Description and Characteristics	3
PGP/PGM 620	
Features of PGP620/PGM620	4
Ordering Code	5
Specifications	6
Dimensions	7
Mounting Flange Options	8
Port Options	9
Drive Shaft Options	11
Performance Data	13
Valve Options For Pumps	14
Pressure Relief Valve	14
Solenoid Unloading Pressure Relief Valve	15
Unloading Relief Valve, Pressure Operated	15
Unloading Relief Valve, Solenoid Operated	16
Priority Flow Divider	16
Load Sense Priority Valve	17
Two-Stage Pump	17
Single Accumulator Charge Valve	18
Dual Accumulator Charge Valve	18
Steering and Accumulator Charge (STAC) Valve	19
Composite Priority and Accumulator Charge Valve	19
Valve Options For Motors	20
Single Pressure Relief Valve with Anti-Cavitation	20
Cross Port Pressure Relief Valve with Anti-Cavitation	20
Solenoid Unloading Pressure Relief Valve for Motors	21
Check Valve and Restrictor	21
Offer of Sale	22

Pump/Motor Products

PGP/PGM 620

- 41 gpm @ 3,000 rpm
- Pressures to 275 bar
- Speeds to 3500 RPM



PGP/PGM 620

Parker Hydraulics has supplied gear pumps and motors to worldwide mobile and industrial markets for many years, especially material handling, turf care, and construction equipment applications. Many Parker pumps and motors have been developed and tested for the specific needs of these industries.

Parker's defined strategy to provide engineered solutions, coupled with an award-winning flexible manufacturing system has resulted in a wide range of SAE/DIN/European and other special options being available as standard.

Features of PGP/PGM 620

- Patented, interlocking body design
- 12 tooth gears, bronze thrust plates
- Tandem, triple and cross-frame pumps available
- Common inlets available for tandem and triple pumps
- Continuous operating pressures up to 275 bar
- Production run-in available to suit OEM application conditions and to provide optimized volumetric efficiencies

PGP 620



- Pressure balanced design for high efficiency
- Reduced system noise levels compared to earlier models and competitors' pumps
- High power through-drive capability
- Wide range of integral valves for power steering, power brakes, fan drives and implement hydraulics
- Load sense and solenoid-operated unloading valves

Characteristics

Product Features	Description
Pump type	Heavy-duty, cast iron, external gear.
Mounting	SAE, Rectangular. Specials on request.
Ports	SAE and metric split flanges and others.
Shaft style	SAE splined, keyed, tapered, cylindrical. Specials on request.
Speed	500 - 3500 rpm, see tables.
Theor. displacem.	See tables
Drive	Drive direct with flexible coupling is recommended.
Inlet pressure	Operating range absolute pressure 0.8 to 2 bar. Absolute minimum inlet pressure 0.5 bar, short time without load. Consultation is recommended.
Outlet pressure	See tables
Axial / Radial load	Axial or Radial loading is not allowed.
Hydraulic fluids	Mineral oil Fire resistant fluids: - water-oil emulsions 60/40, HFB - water-glycol, HFC - phosphate-esters, HFD Engineering approval is recommended.
Fluid temperature	Range of operating temperature -15 to +80°C. Max. permissible operating pressure dependent on fluid temperature. Temperature for cold start -20 to -15°C at speed ≤ 1500 rpm. Max. permissible operating pressure dependent on fluid temperature.

Product Features	Description
Fluid viscosity	Range of operating viscosity 20 to 100 mm ² /s. Max. operating viscosity should not exceed 1000 mm ² /s. Recommended min. viscosity 8 mm ² /s.
Range of ambient temperature	-40°C - +70°C
Filtration	According to ISO 4406 Cl. 16/13
Flow velocity	See tables.
Direction of rotation	Clockwise, counter-clockwise or double.
Multiple pump assemblies	- Available in two or three section configurations. - Max. shaft loading must conform to the limitations shown in the Shaft Load Rating table in this catalog. - The max. load is determined by adding the torque values for each pumping section that will be simultaneously loaded.
Separate or common inlet capability	Separate Inlet configuration: - Each gear housing has individual inlet and outlet ports. Common Inlet configuration: - Two or more gear sets share a common inlet.

PGP/PGM 620 How to Specify

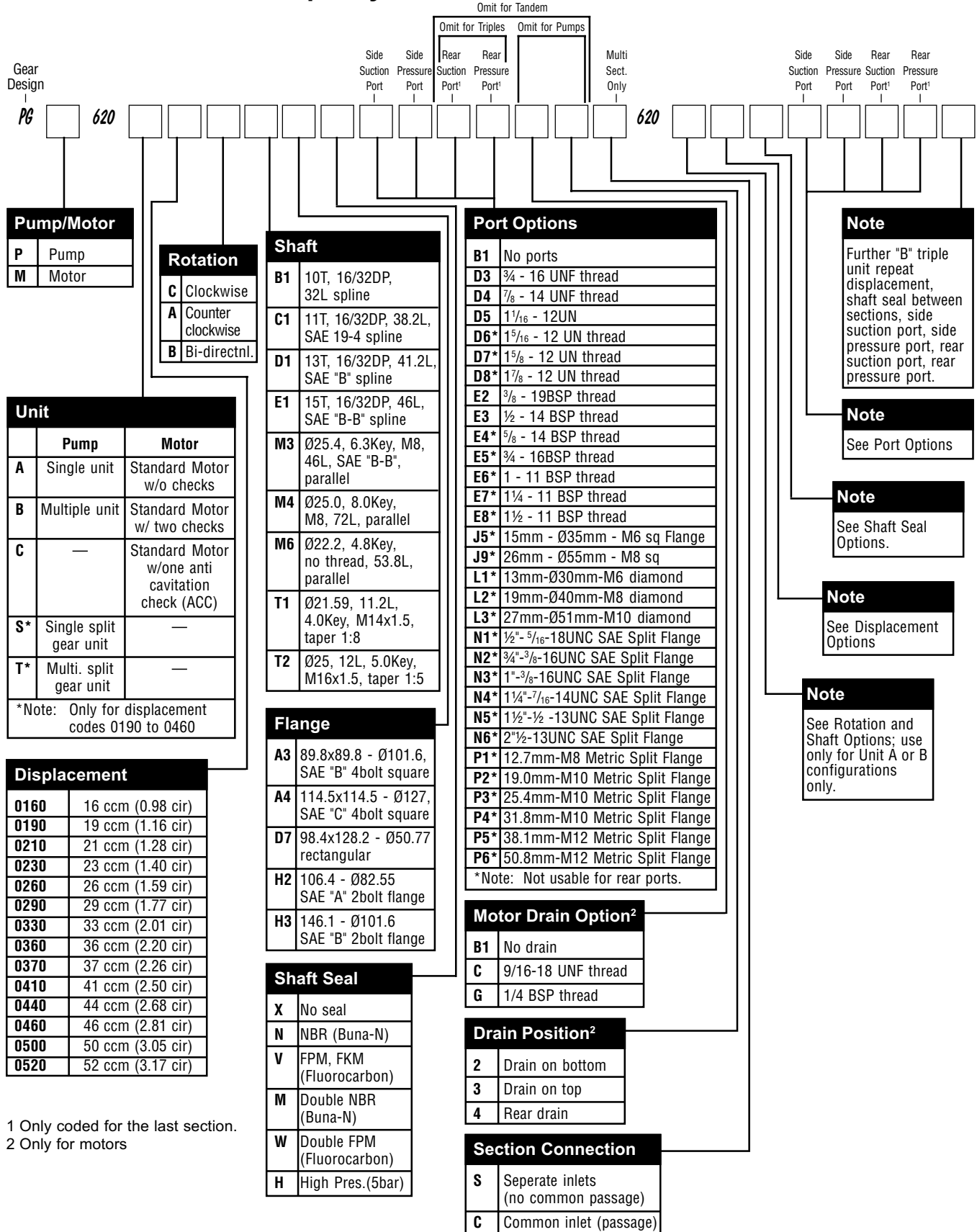

PGP/PGM 620 Dimensions

PGP/PGM 620 Specification - Standard Displacements - Single Unit

Pump Displacement	Code	0160	0190	0210	0230	0260	0290	0330	0360	0370	0410	0440	0460	0500	0520	
		cm ³ /rev	16.0	19.0	21.0	23.0	26.0	29.0	33.0	36.0	37.0	41.0	44.0	46.0	50.0	52.0
		in ³ /rev	.98	1.16	1.28	1.4	1.6	1.8	2.01	2.2	2.3	2.5	2.7	2.8	3.1	3.2
Continuous Press.	bar psi	275	275	275	275	275	275	275	250	250	220	210	210	210	210	210
Intermittent Press.	bar psi	300	300	300	300	300	300	300	275	275	245	230	220	210	210	210
Minimum Speed @ Max. outlet press.	rpm	500	500	500	500	500	500	500	500	500	500	500	500	500	500	500
Maximum Speed @ 0 Inlet & Max. outlet press.	rpm	3500	3500	3500	3500	3500	3500	3500	3500	3500	3500	3500	3500	3000	3000	3000
Dimension "X"	mm	79.2	82.5	84.7	86.9	90.2	93.5	97.9	101.2	102.3	106.7	110.0	112.2	116.6	118.8	
	in	3.1	3.2	3.3	3.4	3.6	3.7	3.9	4.0	4.0	4.2	4.3	4.4	4.6	4.7	
Dimension "Y"	mm	120.2	123.5	125.7	127.9	131.2	134.5	138.9	142.2	143.3	147.7	151.0	153.2	157.6	159.8	
	in	4.7	4.9	4.9	5.0	5.2	5.3	5.5	5.6	5.6	5.8	5.9	6.0	6.2	6.3	
Approx. Weight	kg	12.0	12.1	12.1	12.2	12.3	12.6	12.7	12.8	12.9	13.0	13.1	13.2	13.3	13.4	
	lb	26.4	26.6	26.6	26.8	27.1	27.7	27.9	28.1	28.4	28.6	28.8	29.04	29.3	29.5	

Single Unit PGP/PGM 620

Inch equivalents for millimeter dimensions are shown in (**).

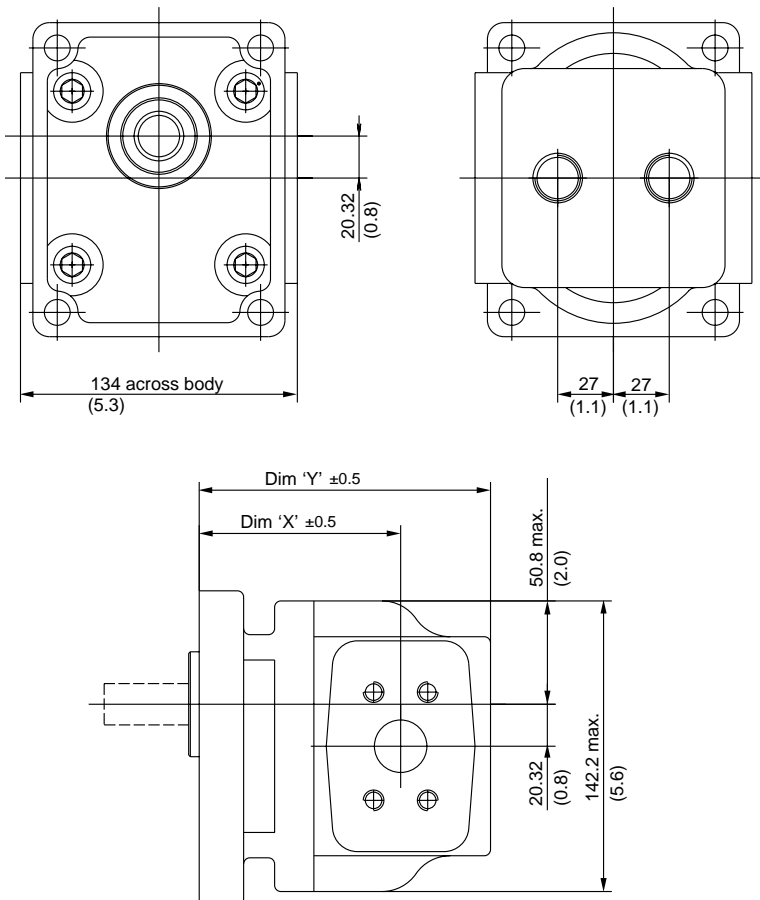

PGP/PGM 620 Dimensions

PGP/PGM 620 Specification - Standard Displacements - Tandem Unit

Pump Displacement	Code	0160	0190	0210	0230	0260	0290	0330	0360	0370	0410	0440	0460	0500	0520	
		cm ³ /rev	16.0	19.0	21.0	23.0	26.0	29.0	33.0	36.0	37.0	41.0	44.0	46.0	50.0	52.0
		in ³ /rev														
Dimension "X"	mm	79.2	82.5	84.7	86.9	90.2	93.5	97.9	101.2	102.3	106.7	110.0	112.2	116.6	118.8	
	in	3.1	3.2	3.3	3.4	3.5	3.7	3.9	4.0	4.0	4.2	4.3	4.4	4.6	4.7	
Dimension "Y1 "	mm	120.2	123.5	125.7	127.9	131.2	134.5	138.9	142.2	143.3	147.7	151.0	153.2	157.6	159.8	
	in	4.7	4.9	4.9	5.0	5.2	5.3	5.5	5.6	5.6	5.8	5.9	6.0	6.2	6.3	
Dimension "Y2" max.	mm	115.2	118.5	120.7	122.9	126.2	129.5	133.9	137.2	138.3	142.7	146.0	148.2	152.6	154.8	
	in	4.5	4.7	4.8	4.8	5.0	5.1	5.3	5.4	5.4	5.6	5.7	5.8	6.0	6.1	
Approximate Weight (front section)	kg	12.0	12.1	12.1	12.2	12.3	12.6	12.7	12.8	12.9	13.0	13.1	13.2	13.3	13.4	
	lb	26.4	26.62	26.62	26.84	27.06	27.72	27.94	28.16	28.38	28.6	28.82	29.04	29.26	29.48	
Approximate Weight (rear section)	kg	10.4	10.5	10.5	10.6	10.7	11.0	11.1	11.2	11.3	11.4	11.5	11.6	11.7	11.8	
	lb	22.88	23.10	23.10	23.32	23.54	24.2	24.42	24.64	24.86	25.08	25.3	25.52	25.74	25.96	

Tandem Unit PGP/PGM 620

Inch equivalents for millimeter dimensions are shown in (**).

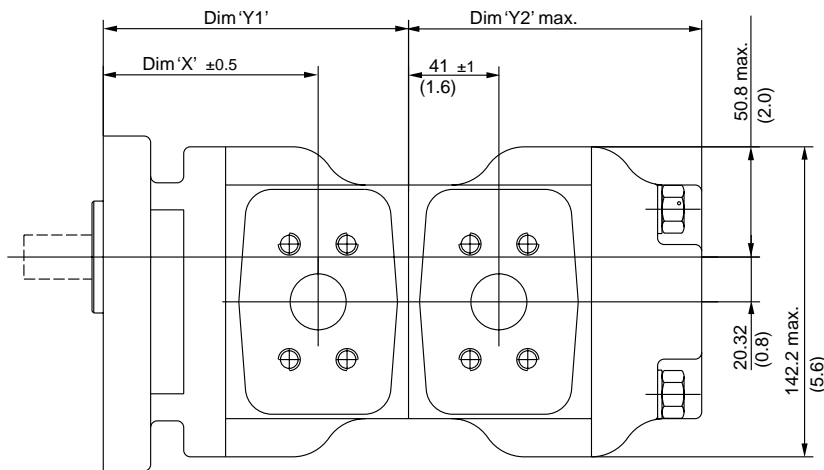
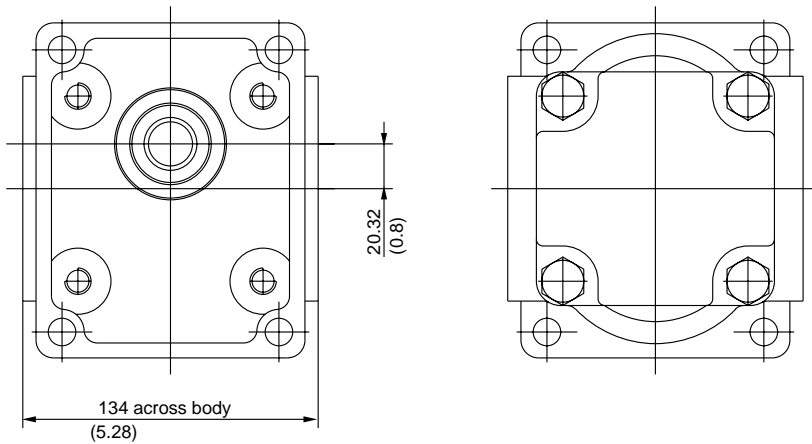

PGP/PGM 620 Mounting Flange

Inch equivalents for millimeter dimensions are shown in (**).

Code A3

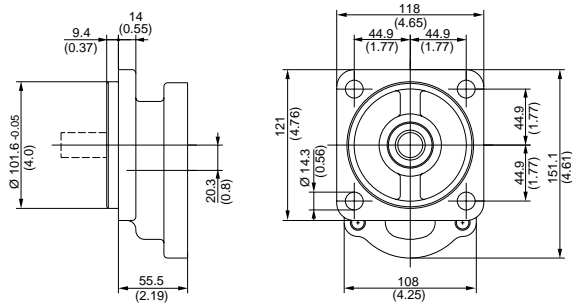

Code A4

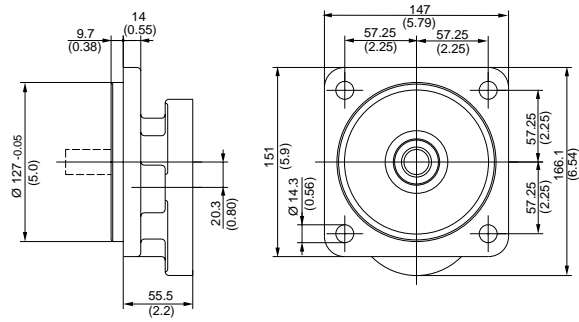

Code D7

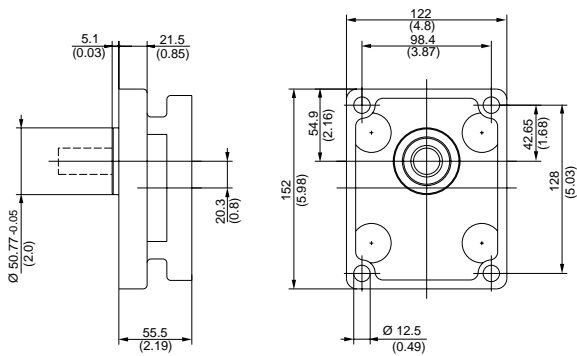

Code H2

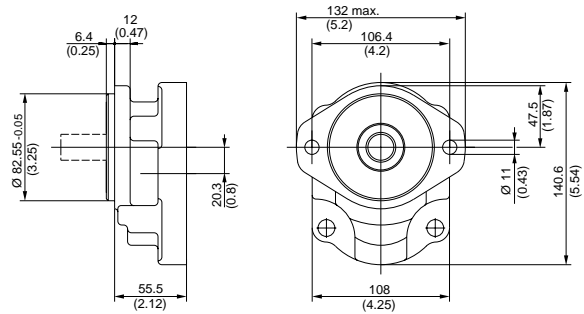

Code H3

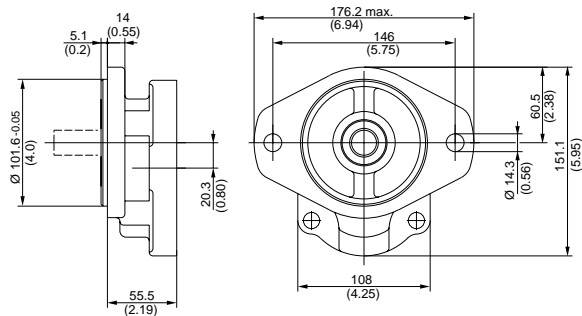

PGP/PGM 620 Porting

Inch equivalents for millimeter dimensions are shown in (**).

Code L
 4-Bolt flange

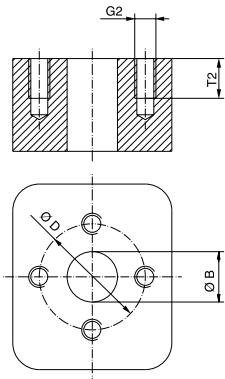

Code J
 European flange

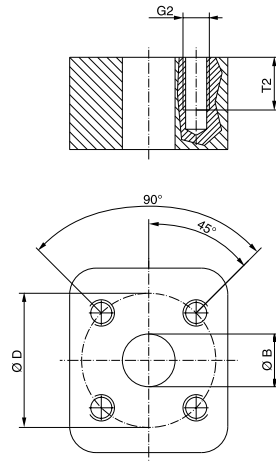

Code N
 SAE split flange

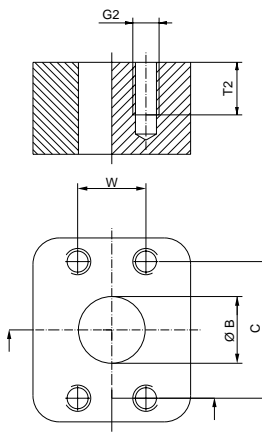

Code P
 SAE split flange metric thread

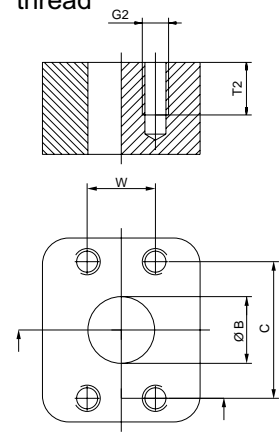

Code D
 SAE straight thread

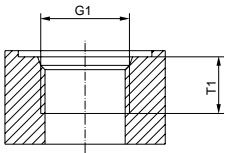

Code E
 BSP - thread

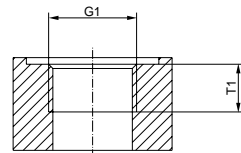

PGP/PGM 620

Code	G2	Ø B	Ø D	C	W	T2
	Thread					
J5	M6	15.0 (0.59)	35.0 (1.38)			12.5 (0.49)
J9	M8	26.0 (1.02)	55.0 (2.17)			15.0 (0.59)
L1	M6	13.0 (0.5)	30.0 (1.18)			13.0 (0.5)
L2	M8	19.0 (0.75)	40.0 (1.57)			15.0 (0.59)
L3	M10	27.0 (1.06)	51.0 (2.01)			18.0 (0.71)
N1	5/16-18 UNC	12.7 (0.5)		38.10 (1.5)	17.48 (0.69)	15.0 (0.59)
N2	3/8-16 UNC	19.0 (0.75)		47.63 (1.88)	22.23 (0.88)	14.0 (0.55)
N3	3/8-16 UNC	25.4 (1.0)		52.37 (2.06)	26.19 (1.03)	20.6 (0.81)
N4	7/16-14 UNC	31.8 (1.25)		58.72 (2.31)	30.17 (1.19)	20.6 (0.81)
N5	1/2-13 UNC	38.1 (1.5)		69.82 (2.75)	35.71 (1.4)	20.6 (0.81)
N6	1/2-13 UNC	50.8 (2.0)		77.77 (3.06)	42.88 (1.69)	20.6 (0.81)
P1	M8	12.7 (0.5)		38.10 (1.5)	17.48 (0.69)	15.0 (0.59)
P2	M10	19.0 (0.75)		47.63 (1.88)	22.23 (0.88)	20.6 (0.81)
P3	M10	25.4 (1.0)		52.37 (2.06)	26.19 (1.03)	21.4 (0.84)
P4	M10	31.8 (1.25)		58.72 (2.31)	30.17 (1.19)	20.6 (0.81)
P5	M12	38.1 (1.5)		69.82 (2.75)	35.71 (1.41)	20.6 (0.81)
P6	M12	50.8 (2)		77.77 (3.06)	42.88 (1.69)	20.6 (0.81)

PGP/PGM 620

Code	G1	T1
	Thread	Dimensions
D3	3/4-16 UNF	14.3 (0.56)
D4	7/8-14 UNF	16.7 (0.68)
D5	1 1/16-12 UN	19.0 (0.75)
D6	1 5/16-12 UN	19.0 (0.75)
D7	1 5/8-12 UN	19.0 (0.75)
D8	1 7/8-12 UN	19.0 (0.75)
E2	3/8-19 BSP	12.0 (0.47)
E3	1/2-14 BSP	14.0 (0.55)
E4	5/8-14 BSP	16.3 (0.64)
E5	3/4-16 BSP	16.0 (0.63)
E6	1-11 BSP	18.0 (0.71)
E7	1 1/4-11 BSP	20.0 (0.79)
E8	1 1/2-11 BSP	22.0 (0.87)

Inch equivalents for millimeter dimensions are shown in (**).

PGP/PGM 620 Drive Shaft

Inch equivalents for millimeter dimensions are shown in (**).

Code B1

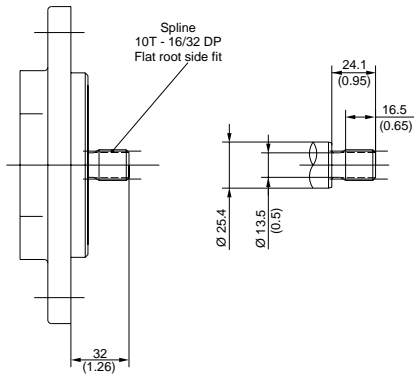

Code C1

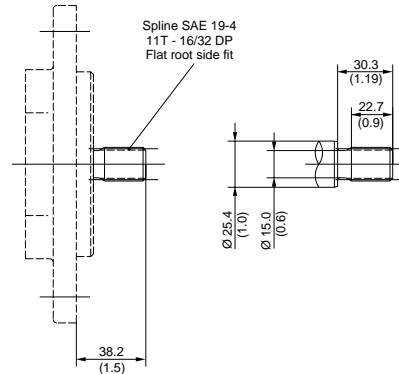

Code D1

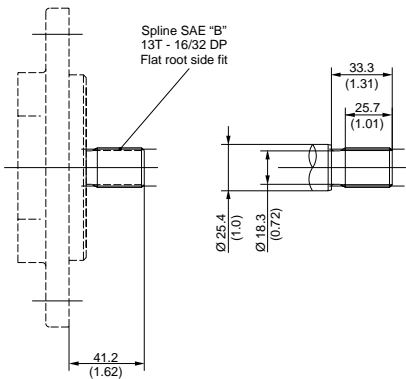

Code E1

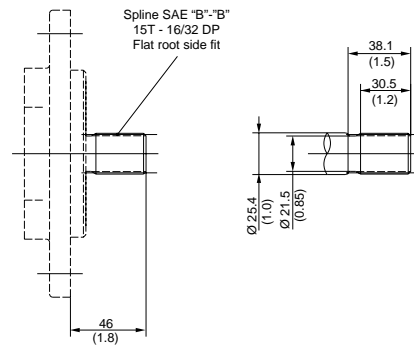

Code M3

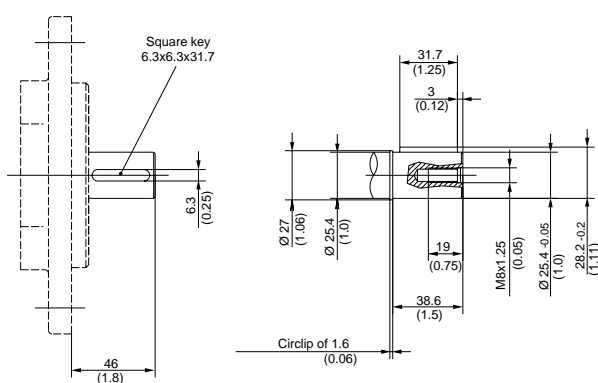

Code M4

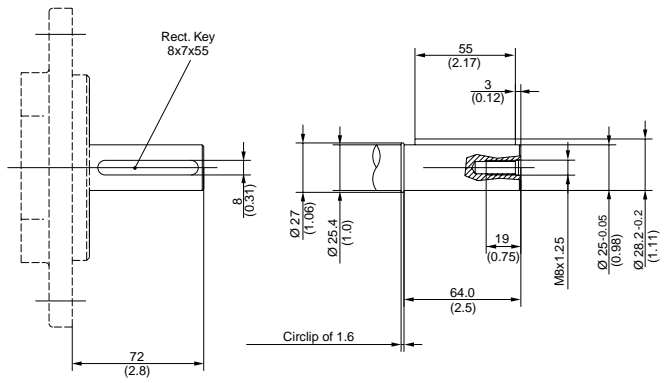

PGP/PGM 620 Drive Shaft

Inch equivalents for millimeter dimensions are shown in (**).

Code M6

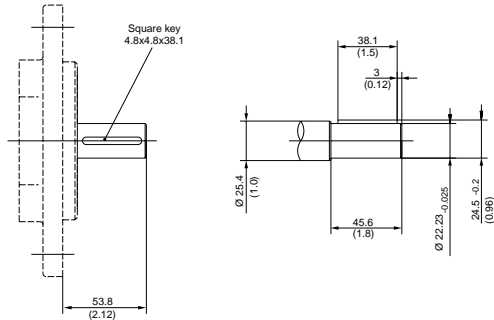

Code T1

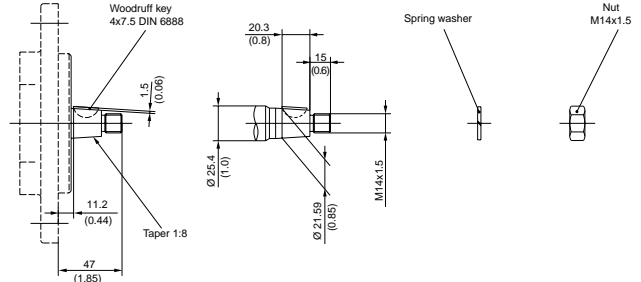

Code T2

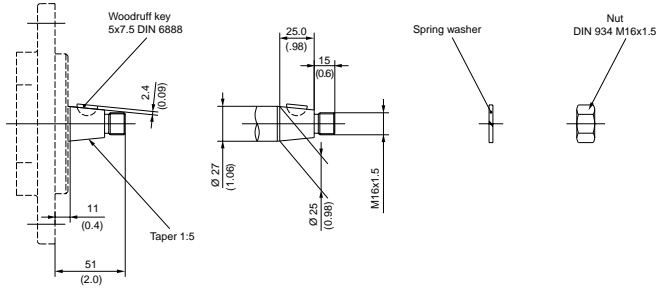

PGP/PGM 620- Shaft Load Capacity

Code	Description	Torque Rating [Nm]
B1 10T,16/32 DP, 32L	spline	124
C1 11T,16/32 DP, 38.2L, SAE 19-4	spline	144
D1 13T,16/32 DP, 41.2L, SAE "B"	spline	272
E1 15T,16/32 DP, 46L, SAE "B-B"	spline	460
M3 Ø25.4,6.3 KEY, M8, 46L, SAE "B-B"	keyed	325
M4 Ø25.0,8.0 KEY, M8, 72L	keyed	325
M6 Ø22.2,4.8 KEY, no thread, 53.8L	keyed	218
T1 Ø21.59,11.2L, 4.0 KEY, M14x1.5	taper 1:8	218
T2 Ø25.0,12.0L, 5.0 KEY, M16x1.5	taper 1:5	301

$$\text{Torque [Nm]} = \frac{\text{Displacement [cm}^3\text{/rev]} \times \text{Pressure [bar]}}{57.2}$$

PGP 620 - 16.0 CC

Fluid Temperature
 Viscosity
 Inlet Pressure

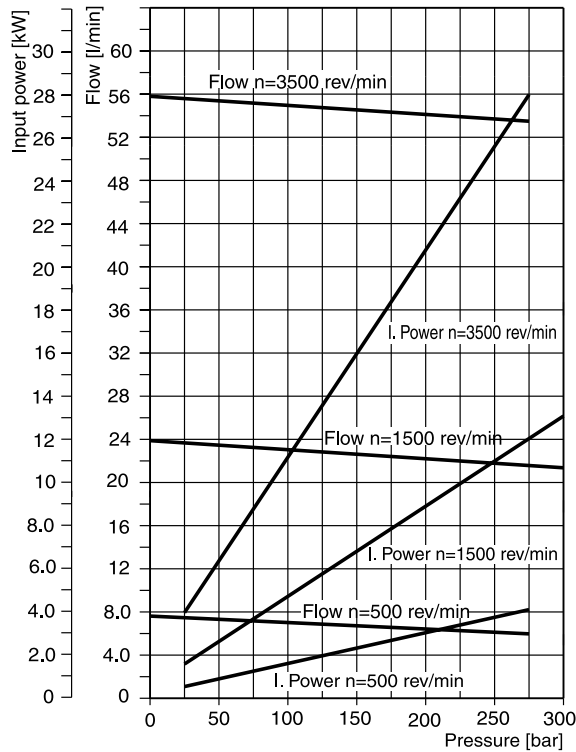

PGP 620 - 26.0 CC

= 45 ± 2°C
 = 36mm²/s
 = 0.9 + 0.1 bar absolute

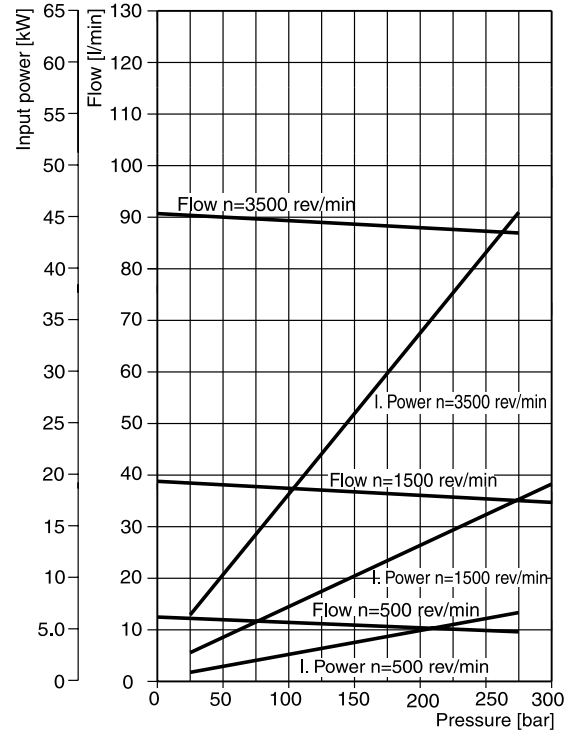

PGP 620 - 41.0 CC

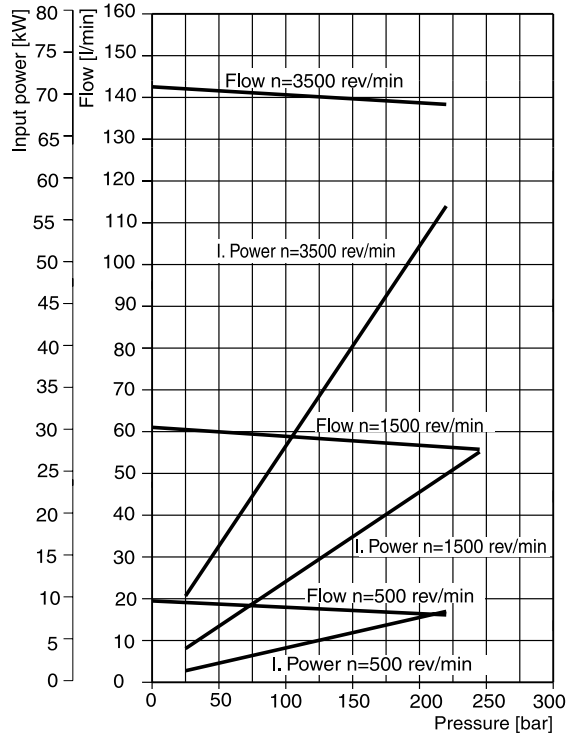

PGP 620 - 52.0 CC

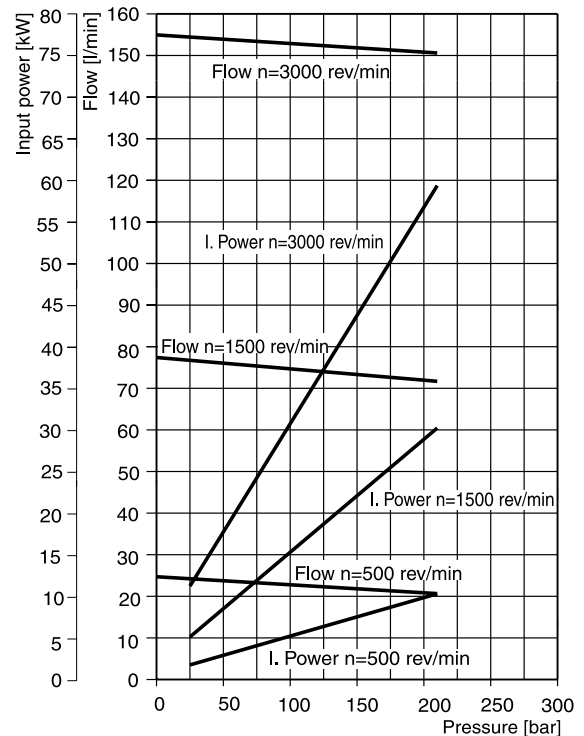

Valve Options

VALVE TYPE	PGP
	620
Pressure Relief Valve	X
Load Sensing Pressure Relief Valve	X
Solenoid Unloading Pressure Relief Valve	X
Pressure Unloading Relief Valve (Port Mounted)	X
Solenoid Unloading Relief Valve (Port Mounted)	X
Priority Flow Divider	X
Priority Flow Divider (Port Mounted)	X
Load Sensing Priority Valve	X
Load Sensing Priority Valve (Port Mounted)	X
Two - Stage Pump	X
Single Accumulator Charge Valve	X
Dual Accumulator Charge Valve	X
Steering and Accumulator Charge Valve (STAC)	X
Composite Priority and Accumulator Charge Valve	X

Pressure Relief Valve

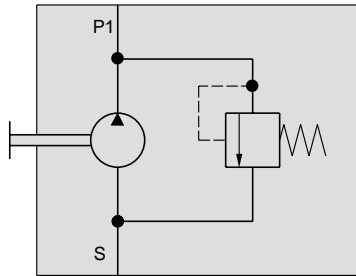

non adjustable, internal vent

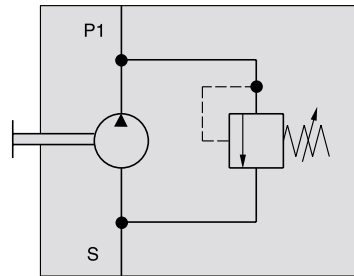

adjustable, internal vent

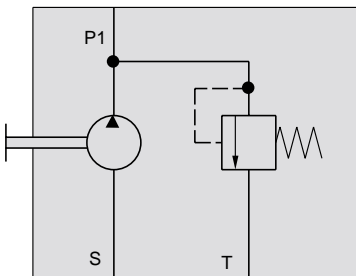

non adjustable, external tank port

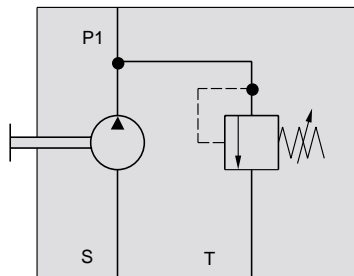

adjustable, external tank port

- Variations:** For PGP620
 Non adjustable, internal vent
 Non adjustable, external tank port
 Adjustable, internal vent
 Adjustable, external tank port

Solenoid Unloading Pressure Relief Valve

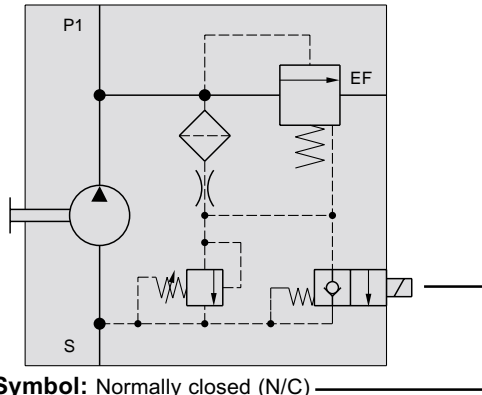

Detailed Symbol: Normally closed (N/C)

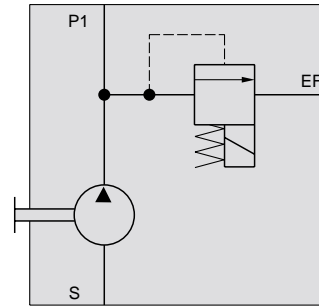

Simplified Symbol

Detailed Symbol  Normally opened (N/O)

- Variations:** For PGP620
 Specify voltage and whether N/O or N/C
- Press. Range:** Stand-by pressure setting 5 bar
 Max. setting 250 bar
- Max. Flow:** For PGP620 100 l/min

Comments:
 This valve utilizes the same casting, main spool, and pilot relief as the Load Sensing Pressure Relief Valve. A small solenoid operated cartridge valve vents the internal pilot flow to pump inlet to unload the main spool. The outlet port is in the pump body and the EF is connected to the reservoir via heat exchanger and/or return line filter.

Unloading Relief Valve, Pressure Operated

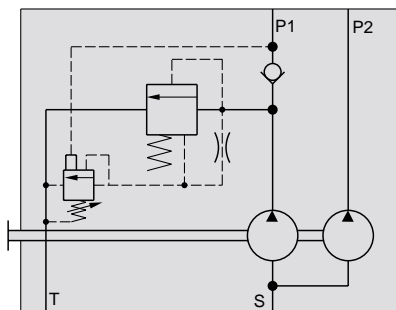

Detailed Symbol

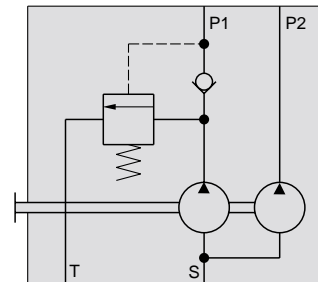

Simplified Symbol

- Variations:** For PGP 620
 Port mounted, integral with pump
- Press. Range:** Stand-by pressure setting 5 bar
 Max. setting 250 bar
 Min setting 55 bar
- Max. Flow:** 80 l/min

Comments:
 This valve permits pressure unloading of the first section in a tandem. The valve may also be remote mounted for use with tandem or dual pumps. The flow from port P1 is typically combined with the flow from port P2. Often used on construction machinery, such as backhoe loaders, wheel loaders and cranes, to provide high flow (from both sections of the tandem) at low or medium pressures and high pressure with reduced flow (from the rear section only). This allows maximum productivity of the machine in accord with the power available to the pump.

Unloading Relief Valve, Solenoid Operated

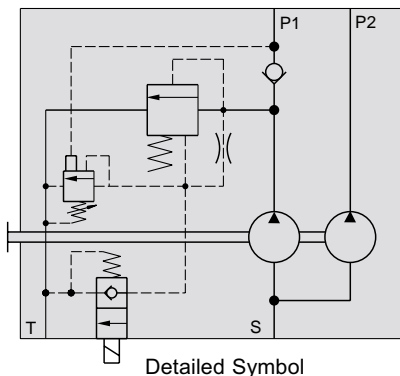

Detailed Symbol

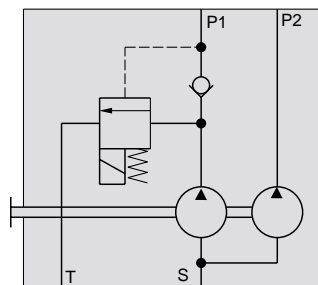

Simplified Symbol

- Variations:** For PGP620
 Port mounted, integral with pump
- Press. Range:** Stand-by pressure setting 5 bar
 Max. setting 250 bar
 Min setting 55 bar
- Max. Flow:** 80 l/min

Comments:

This valve permits pressure or solenoid unloading of the first section in a tandem. The valve may also be remote mounted for use with tandem or dual pumps. The flow from port P1 is typically combined with the flow from port P2. Often used on construction machinery, such as backhoe loaders, wheel loaders and cranes, to provide high flow (from both sections of the tandem) at low or medium pressures and high pressure with reduced flow (from the rear section only). This allows maximum productivity of the machine in accord with the power available to the pump.

Priority Flow Divider

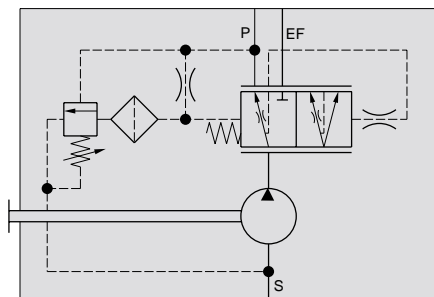

With Pilot Priority Relief Valve

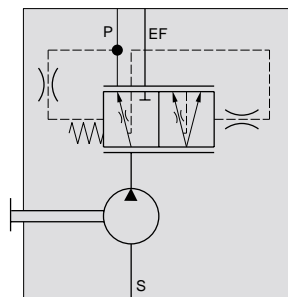

Without Priority Relief Valve

- Variations:** **Rear Mounted Versions:**
 For PGP620
 Without priority relief; With full flow priority relief (not shown)
 With pilot priority relief valve
- Port Mounted Version:**
 For PGP 620
 Without priority relief

- Press. Range:** Priority Port Min. setting 35 bar
 Priority Port Max. setting 210 bar
 Extended Flow Max. equal to max. rating of pump

- Max. Flow:** Valve for Port Mounted Version
 Priority Flow Max. 32 l/min
 Extended Flow Max. 70 l/min
 Max. input flow 70 l/min
- Valve for PGP 620 - Rear Mounted Version
 Priority Flow Max. 45 l/min
 Extended Flow Max. 100 l/min
 Max. input flow 100 l/min

PGP 620 + Valve



Comments:

The Priority Flow Divider provides a constant and specified flow for power steering or other priority functions. The balance of the flow produced by the pump is available from the EF port for additional functions such as open center directional control valves, fan drives, etc.

Load Sense Priority Valve

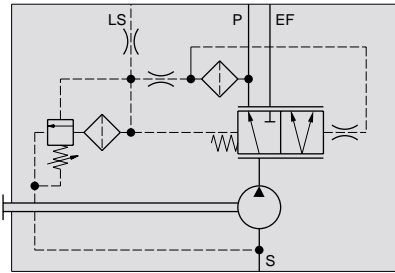

With Priority Relief Valve and for Dynamic LS Signal

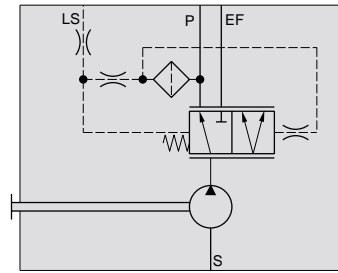

Without Priority Relief Valve and for Dynamic LS Signal

- Variations:**
- Rear Mounted Versions:**
 For PGP620
 Without relief, static LS signal;
 With pilot relief, dynamic LS signal
 Without relief, dynamic LS signal;
 With pilot relief, dynamic LS signal
 - Port Mounted Version:**
 For PGP620
 Without relief, static LS signal;
 Without relief, dynamic LS signal

- Press. Range:** Priority Port Min. setting 35 bar
 Priority Port Max. setting 210 ba
 Extended Flow Max. equal
 to max. rating of pump
- Max. Flow:**
- | | |
|--------------------------------|-----------|
| Valve for Port Mounted Version | |
| Priority Flow Max. | 32 l/min |
| Extended Flow Max. | 70 l/min |
| Max. input flow | 70 l/min |
| Valve for PGP620 | |
| Priority Flow Max. | 45 l/min |
| Extended Flow Max. | 100 l/min |
| Max. input flow | 100 l/min |

Comments:
 The Load Sensing Priority Valve provides priority flow on demand, typically for LS power steering. The balance of the flow produced by the pump is available from the EF port for additional functions such as open center directional control valves, fan drives, etc. When the power steering is idle, full pump flow is available for these functions. The selection of pilot relief and static or dynamic signal is dependent on the characteristics of the selected steering unit.

Two - Stage Pump

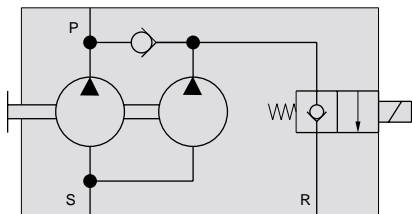

With External Tank Port (recommended)

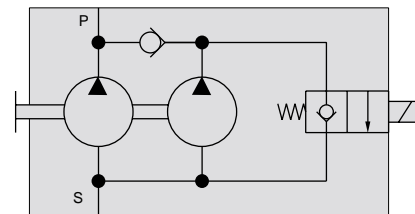

With Internal Vent to Pump Inlet

- Variations:**
- For PGP620
 - With internal vent to inlet
 - With external tank port
 - Note: Specify solenoid voltage

- Press. Range:** To application requirements
- Rated Flow:** A variety of solenoid valves are available. Selection of valve size and flow rate is in accordance with application requirements.

Comments:
 The Parker Two-Stage or High-Low pump is a tandem with equal or dissimilar displacements and a two position / two way valve in the rear cover to allow unloading of the rear pump. This pump is applied when the prime mover (engine or electric motor) has limited power. When high pressure is required, the rear section is unloaded to the pump inlet or the tank. When high flow is required at low or medium pressure, the flow of both sections is combined at the outlet port P. In both cases, the displacements and pressures are selected to be within the power limits of the prime mover.

Note: When the internal vent to the inlet is selected, caution is suggested to prevent operating in the unloading condition for extended periods. The heat generated in doing so may lower the fluid viscosity below minimums required for the pump possibly damaging the pump.

Single Accumulator Charge Valve

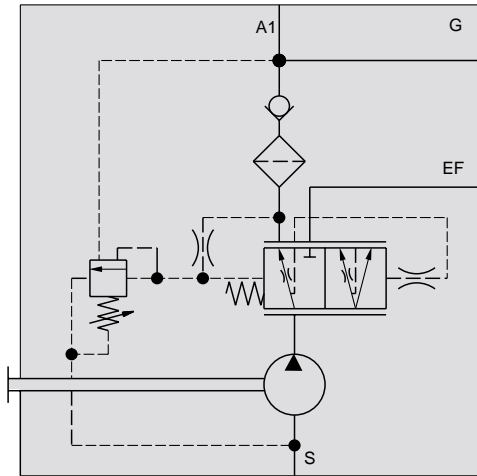

Variations:	For PGP620	
	Integral with pump	100 l/min
Press. Range:	A1, G Ports Min. setting	35 bar
	A1, G Ports Max. setting	210 bar
	Extended Flow Max. equal to	
	max. rating of pump	
Max. Flow:	Valve for PGP620	
	Charge Flow Max.	45 l/min
	Extended Flow Max.	100 l/min
	Max. Input Flow	100 l/min

Comments:

The Single Accumulator Charge Valve (SACV) provides priority flow to charge an accumulator for vehicle brakes or any application requiring stored hydraulic energy. The SACV has an integral differential pilot relief valve to provide a wide variety of cut-in/cut-out pressure ratios. Typical ratios are 80%, 70%, 60% and 50%. Custom ratios are available for OEM applications. A variety of port locations and sizes are available. The balance of the pump flow at the EF port is available for an open circuit directional control valve, fan drive or other ancillary functions.

Dual Accumulator Charge Valve

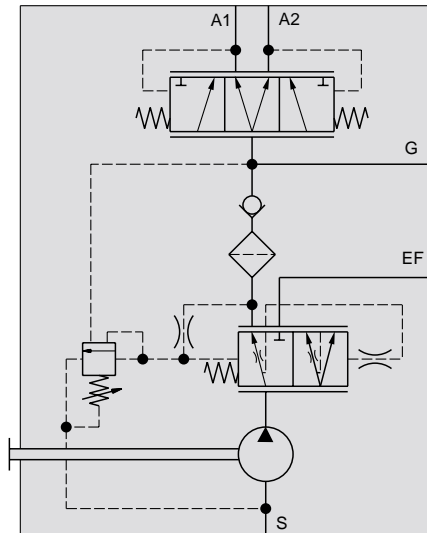

Variations:	For PGP620	
	Integral with pump	100 l/min
Press. Range:	A1, A2, G Ports Min. setting	35 bar
	A1, A2 G Ports Max. setting	210 bar
	Extended Flow Max. equal to	
	max. rating of pump	
Max. Flow:	Valve for PGP620	
	Charge Flow Max.	45 l/min
	Extended Flow Max.	100 l/min
	Max. Input Flow	100 l/min

Comments:

The Dual Accumulator Charge Valve provides priority flow to charge two accumulators for dual circuit vehicle brakes or any application requiring stored hydraulic energy. The Dual Accumulator Charge Valve has an integral differential pilot relief valve to provide a wide variety of cut-in/cut-out pressure ratios. Typical ratios are 80%, 70%, 60% and 50%. Custom ratios are available for OEM applications. An inverse shuttle spool isolates the two circuits so that pressure and oil volume is maintained in one circuit should the other experience a break in the hydraulic line. A variety of port locations and sizes is available.

Steering & Accumulator Charge (STAC) Valve

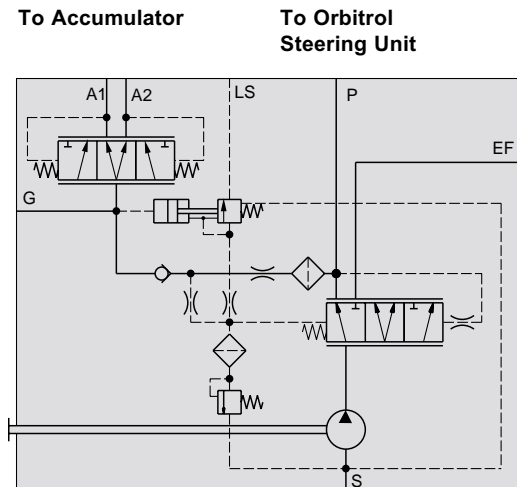

- Variations:** Integral with PGP 620 pump
 Single or dual accumulator charge circuit
 (Dual circuit schematic shown)
- Press. Range:** A1, A2, Port Min. setting 35 bar
 A1, A2, Port Max. setting 210 bar
 Priority Port Max. setting 210 bar
 Extended Flow Max. equal to max. rating of pump
 Steering stand-by pressure up to 20 bar
- Rated Flows:** Total Charge Flow up to 60 l/min
 depending on stand-by pressure
 Priority Port 45 l/min
 Extended Flow Max. 100 l/min
 Max. Input Flow 100 l/min

Comments:

The combined LS Priority Valve and Accumulator Charge Valve provides equal priority flow to load sense power steering and to charge one or more accumulators for hydraulic vehicle brakes. Excess pump flow is available from the EF port for the implement hydraulics, fan drives or other services. The accumulator charge function has an differential pilot relief valve to provide a wide variety of cut-in/cut-out pressure ratios. Typical ratios are 80%, 70%, 60% and 50%. Custom ratios are available for OEM applications. Steering relief pressure (at P port) must be equal to or greater than maximum charge cut-out pressure. Valve is available with inverse shuttle for dual circuit braking systems (above schematic) or without inverse shuttle for single braking systems.

Composite Load Sense Priority and Accumulator Charge Valve

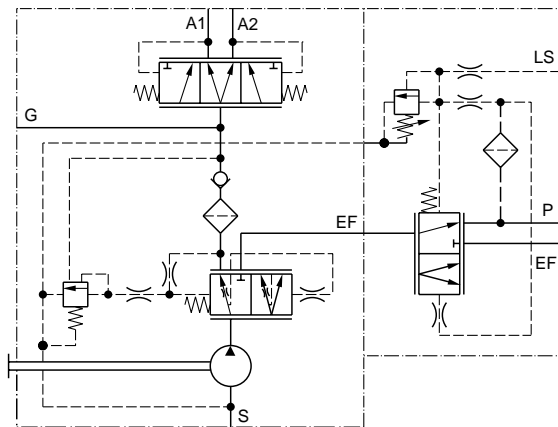

- Variations:** Integral with PGP 620 pump
 Single accumulator charge valve + Load sensing priority valve
 Dual accumulator charge valve + Load sensing priority valve (schematic shown)
 Single accumulator charge valve + Priority flow divider
 Dual accumulator charge valve + Priority flow divider
- Press. Range:** A1, A2, G Port Min. setting 35 bar
 A1, A2, G Port Max. setting 210 bar
 Priority Port Max. setting 210 bar
 Extended Flow Max. equal to max. rating of pump
- Rated Flow:** Charge Max. 45 l/min
 Extended Flow Max. 100 l/min
 Max. Input Flow 100 l/min

Comments:

The Composite Load Sense Priority and Accumulator Charge Valve provides first priority flow to charge one or two accumulators for vehicle brakes and second priority to power steering. The balance of the pump flow at the EF port is available for an open circuit directional control valve. The accumulator charge valve has an integral differential pilot relief valve to provide a wide variety of cut-in/cut-out pressure ratios. Typical ratios are 80%, 70%, 60% and 50%. Custom ratios are available for OEM applications. The combination is possible with Single and Dual Accumulator Charge Valves or Priority Flow Dividers. The composite Valve is also available for remote mounting.

Motors

Valve type	PGM
	620
Single Pressure Relief Valve	X
Single Pressure Relief Valve with Anti-Cavitation	X
Cross Port Pressure Relief Valve	X
Cross Port Pressure Relief Valve with Anti-Cavitation	X
Solenoid Unloading Pressure Relief Valve for Motors	X
Check Valve and Restrictor	X

Single Pressure Relief Valve with Anti-Cavitation

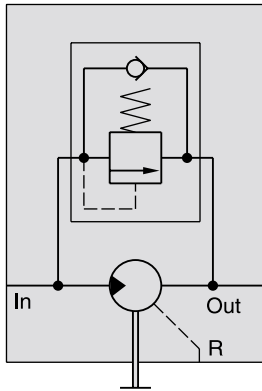

- Variations:** For PGM 620
 Reverse flow check
 With internal or external drain
- Press. Range:** Min. setting 25 bar
 Max. setting 250 bar
- Applications:** Compressor drives, fan drives, mower blade drives and water pump drives

Comments:

Integral relief to protect motor. Motors fitted with this relief valve may be applied in series with the relief valve providing a limit to the pressure differential, and hence, the output torque. The check valve allows the motor and driven load to “spool down” when the fluid supply is shut off or reduced due to engine speed fluctuations. In series operation, the check valve permits the motor to come to a controlled stop should the outlet flow be suddenly blocked. This check valve reduces the risk of damaging the motor or blowing a hydraulic line. Motors fitted with this valve are available with side or rear facing ports.

Cross Port Pressure Relief Valve with Anti-Cavitation

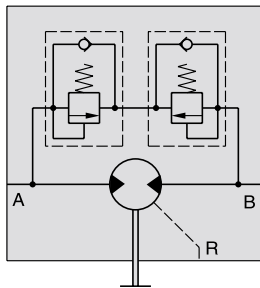

- Variations:** For PGM620
 Non adjustable, with reverse flow check
 With internal or external drain
- Press. Range:** Min. setting 25 bar
 Max. setting 250 bar
- Applications:** Mower blade drives, water pump drives and reversible hydrostatic transmissions

Comments:

Motors fitted with this relief valve may be applied in series or in a hydrostatic transmission with the relief valve providing a limit to the pressure differential, and hence, the output torque. The check valves allow flow to return to the inlet of the motor to prevent cavitation. Available with side, rear, or combination of side and rear ports.

Solenoid Unloading Pressure Relief Valve for Motors

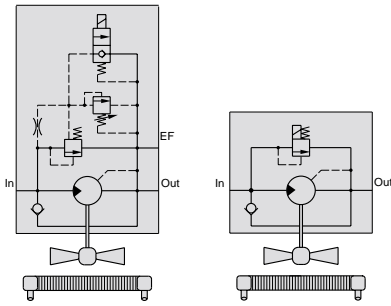

- Variations:** For PGM620
 With internal return for single motor operation
 With tank port for series motor operation
 Specify solenoid voltage, whether N/O or N/C
- Press. Range:** Stand-by pressure differential 5 bar
 Max. setting 250 bar
- Max. Flow:** For PGM 620 100 l/min

Comments:

This valve is similar to the solenoid unloading relief valve used on PGM 620. A small solenoid operated cartridge valve vents the internal pilot to the motor outlet to unload the main spool. The outlet port is connected to tank via filter and heat exchanger (if installed). The motor control can be set to provide low speed operation rather than coming to a full stop. This allows a quiet start for the fan as it will start from approximately 100 rpm. The solenoid in the valve can be supplied for normally open or normally closed operation. The anti-cavitation check valve allows motor spool-down, when the engine is shut down with the fan running.

Check Valve and Restrictor

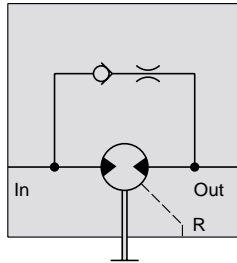

- Variations:** For PGM620
 Metered flow from motor outlet to inlet
- Press. Range:** Max. setting 250 bar
- Max. Flow:** 30 l/min
- Applications:** Mower blade drives, winch drives, and blower drives

Comments:

The Check Valve and Restrictor is used to control pressure spikes between motors in series circuit. The check valve allows the motor and driven load to “spool down” when the fluid supply is shut off, or reduced due to engine speed fluctuations. In series operation, the check valve permits the motor to come to a controlled stop should the outlet flow be suddenly blocked. This check valve reduces the risk of damaging the motor or blowing a hydraulic line. The restrictor valve permits operation in reverse with reduced efficiency for cleaning debris or backlapping of the cutters.

The items described in this document and other documents or descriptions provided by Parker Hannifin Corporation, its subsidiaries and its authorized distributors are hereby offered for sale at prices to be established by Parker Hannifin Corporation, its subsidiaries and its authorized distributors. This offer and its acceptance by any customer ("Buyer") shall be governed by all of the following Terms and Conditions. Buyer's order for any such items, when communicated to Parker Hannifin Corporation, its subsidiary or an authorized distributor ("Seller") verbally or in writing, shall constitute acceptance of this offer.

1. Terms and Conditions of Sale: All descriptions, quotations, proposals, offers, acknowledgments, acceptances and sales of Seller's products are subject to and shall be governed exclusively by the terms and conditions stated herein. Buyer's acceptance of any offer to sell is limited to these terms and conditions. Any terms or conditions in addition to, or inconsistent with those stated herein, proposed by Buyer in any acceptance of an offer by Seller, are hereby objected to. No such additional, different or inconsistent terms and conditions shall become part of the contract between Buyer and Seller unless expressly accepted in writing by Seller. Seller's acceptance of any offer to purchase by Buyer is expressly conditional upon Buyer's assent to all the terms and conditions stated herein, including any terms in addition to, or inconsistent with those contained in Buyer's offer. Acceptance of Seller's products shall in all events constitute such assent.

2. Payment: Payment shall be made by Buyer net 30 days from the date of delivery of the items purchased hereunder. Amounts not timely paid shall bear interest at the maximum rate permitted by law for each month or portion thereof that the Buyer is late in making payment. Any claims by Buyer for omissions or shortages in a shipment shall be waived unless Seller receives notice thereof within 30 days after Buyer's receipt of the shipment.

3. Delivery: Unless otherwise provided on the face hereof, delivery shall be made F.O.B. Seller's plant. Regardless of the method of delivery, however, risk of loss shall pass to Buyer upon Seller's delivery to a carrier. Any delivery dates shown are approximate only and Seller shall have no liability for any delays in delivery.

4. Warranty: Seller warrants that the items sold hereunder shall be free from defects in material or workmanship for a period of 18 months from date of shipment from Parker Hannifin Corporation. **THIS WARRANTY COMPRISES THE SOLE AND ENTIRE WARRANTY PERTAINING TO ITEMS PROVIDED HEREUNDER. SELLER MAKES NO OTHER WARRANTY, GUARANTEE, OR REPRESENTATION OF ANY KIND WHATSOEVER. ALL OTHER WARRANTIES, INCLUDING BUT NOT LIMITED TO, MERCHANTABILITY AND FITNESS FOR PURPOSE, WHETHER EXPRESS, IMPLIED, OR ARISING BY OPERATION OF LAW, TRADE USAGE, OR COURSE OF DEALING ARE HEREBY DISCLAIMED. NOTWITHSTANDING THE FOREGOING, THERE ARE NO WARRANTIES WHATSOEVER ON ITEMS BUILT OR ACQUIRED WHOLLY OR PARTIALLY, TO BUYER'S DESIGNS OR SPECIFICATIONS.**

5. Limitation Of Remedy: SELLER'S LIABILITY ARISING FROM OR IN ANY WAY CONNECTED WITH THE ITEMS SOLD OR THIS CONTRACT SHALL BE LIMITED EXCLUSIVELY TO REPAIR OR REPLACEMENT OF THE ITEMS SOLD OR REFUND OF THE PURCHASE PRICE PAID BY BUYER, AT SELLER'S SOLE OPTION. IN NO EVENT SHALL SELLER BE LIABLE FOR ANY INCIDENTAL, CONSEQUENTIAL OR SPECIAL DAMAGES OF ANY KIND OR NATURE WHATSOEVER, INCLUDING BUT NOT LIMITED TO LOST PROFITS ARISING FROM OR IN ANY WAY CONNECTED WITH THIS AGREEMENT OR ITEMS SOLD HEREUNDER, WHETHER ALLEGED TO ARISE FROM BREACH OF CONTRACT, EXPRESS OR IMPLIED WARRANTY, OR IN TORT, INCLUDING WITHOUT LIMITATION, NEGLIGENCE, FAILURE TO WARN OR STRICT LIABILITY.

6. Changes, Reschedules and Cancellations: Buyer may request to modify the designs or specifications for the items sold hereunder as well as the quantities and delivery dates thereof, or may request to cancel all or part of this order, however, no such requested modification or cancellation shall become part of the contract between Buyer and Seller unless accepted by Seller in a written amendment to this Agreement. Acceptance of any such requested modification or cancellation shall be at Seller's discretion, and shall be upon such terms and conditions as Seller may require.

7. Special Tooling: A tooling charge may be imposed for any special tooling, including without limitation, dies, fixtures, molds and patterns, acquired to manufacture items sold pursuant to this contract. Such special tooling shall be and remain Seller's property notwithstanding payment of any charges by Buyer. In no event will Buyer acquire any interest in apparatus belonging to Seller which is utilized in the notwithstanding any charges paid by Buyer. Unless otherwise agreed, Seller shall have the right to alter, discard or otherwise dispose of any special tooling or other property in its sole discretion at any time.

8. Buyer's Property: Any designs, tools, patterns, materials, drawings, confidential information or equipment furnished by Buyer or any other items which become Buyer's property, may be considered obsolete and may be destroyed by Seller after two (2) consecutive years have elapsed without Buyer placing an order for the items which are manufactured using such property, Seller shall not be responsible for any loss or damage to such property while it is in Seller's possession or control.

9. Taxes: Unless otherwise indicated on the face hereof, all prices and charges are exclusive of excise, sales, use, property, occupational or like taxes which may be imposed by any taxing authority upon the manufacture, sale or delivery of the items sold hereunder. If any such taxes must be paid by Seller or if Seller is liable for the collection of such tax, the amount thereof shall be in addition to the amounts for the items sold. Buyer agrees to pay all such taxes or to reimburse Seller therefore upon receipt of its invoice. If Buyer claims exemption from any sales, use or other tax imposed by any taxing authority, Buyer shall save Seller harmless from and against any such tax, together with any interest or penalties thereon which may be assessed if the items are held to be taxable.

10. Indemnity For Infringement of Intellectual Property Rights: Seller shall have no liability for infringement of any patents, trademarks, copyrights, trade dress, trade secrets or similar rights except as provided in this Part 10. Seller will defend and indemnify Buyer against allegations of infringement of U.S. Patents, U.S. Trademarks, copyrights, trade dress and trade secrets (hereinafter 'Intellectual Property Rights'). Seller will defend at its expense and will pay the cost of any settlement or damages awarded in an action brought against Buyer based on an allegation that an item sold pursuant to this contract infringes the Intellectual Property Rights of a third party. Seller's obligation to defend and indemnify Buyer is contingent on Buyer notifying Seller within ten (10) days after Buyer becomes aware of such allegations of infringement, and Seller having sole control over the defense of any allegations or actions including all negotiations for settlement or compromise. If an item sold hereunder is subject to a claim that it infringes the Intellectual Property Rights of a third party, Seller may, at its sole expense and option, procure for Buyer the right to continue using said item, replace or modify said item so as to make it noninfringing, or offer to accept return of said item and return the purchase price less a reasonable allowance for depreciation. Notwithstanding the foregoing, Seller shall have no liability for claims of infringement based on information provided by Buyer, or directed to items delivered hereunder for which the designs are specified in whole or part by Buyer, or infringements resulting from the modification, combination or use in a system of any item sold hereunder. The foregoing provisions of this Part 10 shall constitute Seller's sole and exclusive liability and Buyer's sole and exclusive remedy for infringement of Intellectual Property Rights.

If a claim is based on information provided by Buyer or if the design for an item delivered hereunder is specified in whole or in part by Buyer, Buyer shall defend and indemnify Seller for all costs, expenses or judgments resulting from any claim that such item infringes any patent, trademark, copyright, trade dress, trade secret or any similar right.

11. Force Majeure: Seller does not assume the risk of and shall not be liable for delay or failure to perform any of Seller's obligations by reason of circumstances beyond the reasonable control of Seller (hereinafter 'Events of Force Majeure'). Events of Force Majeure shall include without limitation, accidents, acts of God, strikes or labor disputes, acts, laws, rules or regulations of any government or government agency, fires, floods, delays or failures in delivery of carriers or suppliers, shortages of materials and any other cause beyond Seller's control.

12. Entire Agreement/Governing Law: The terms and conditions set forth herein, together with any amendments, modifications and any different terms or conditions expressly accepted by Seller in writing, shall constitute the entire Agreement concerning the items sold, and there are no oral or other representations or agreements which pertain thereto. This Agreement shall be governed in all respects by the law of the State of Ohio. No actions arising out of the sale of the items sold hereunder or this Agreement may be brought by either party more than two (2) years after the cause of action accrues.

9/91P



Parker Hannifin Corporation
 6035 Parkland Blvd.
 Cleveland, Ohio 44124-4141
 Telephone: (216) 896-3000
 Fax: (216) 896-4000
 Web site: www.parker.com

Parker Hannifin Corporation

About Parker Hannifin Corporation

Parker Hannifin is a leading global motion-control company dedicated to delivering premier customer service. A Fortune 500 corporation listed on the New York Stock Exchange (PH), our components and systems comprise over 1,400 product lines that control motion in some 1,000 industrial and aerospace markets. Parker is the only manufacturer to offer its customers a choice of hydraulic, pneumatic, and electromechanical motion-control solutions. Our Company has the largest distribution network in its field, with over 7,500 distributors serving more than 350,000 customers worldwide.

Parker's Charter

To be a leading worldwide manufacturer of components and systems for the builders and users of durable goods. More specifically, we will design, market and manufacture products controlling motion, flow and pressure. We will achieve profitable growth through premier customer service.

Product Information

North American customers seeking product information, the location of a nearby distributor, or repair services will receive prompt attention by calling the Parker Product Information Center at our toll-free number: 1-800-C-PARKER (1-800-272-7537). In the UK, a similar service is available by calling 0500-103-203.

The Aerospace Group

is a leader in the development, design, manufacture and servicing of control systems and components for aerospace and related high-technology markets, while achieving growth through premier customer service.



The Climate & Industrial Controls Group

designs, manufactures and markets system-control and fluid-handling components and systems to refrigeration, air-conditioning and industrial customers worldwide.



The Fluid Connectors Group

designs, manufactures and markets rigid and flexible connectors, and associated products used in pneumatic and fluid systems.



The Seal Group designs, manufactures and distributes industrial and commercial sealing devices and related products by providing superior quality and total customer satisfaction.



The Hydraulics Group

designs, produces and markets a full spectrum of hydraulic components and systems to builders and users of industrial and mobile machinery and equipment.



The Filtration Group

designs, manufactures and markets quality filtration and clarification products, providing customers with the best value, quality, technical support, and global availability.



The Automation Group

is a leading supplier of pneumatic and electro-mechanical components and systems to automation customers worldwide.



The Instrumentation Group

is a global leader in the design, manufacture and distribution of high-quality critical flow components for worldwide process instrumentation, ultra-high-purity, medical and analytical applications.





Parker Hannifin Corporation
Gear Pump Division
1775 Logan Avenue
Youngstown, OH 44501 USA
Tel: (330) 746-8011
Fax: (330) 746-1148
<http://www.parker.com/gearpump>

Catalog HY09-620/US
5M, 10/03, T&M